

Project planning guide

cyber[®] kit line medium

Servo motors without housing

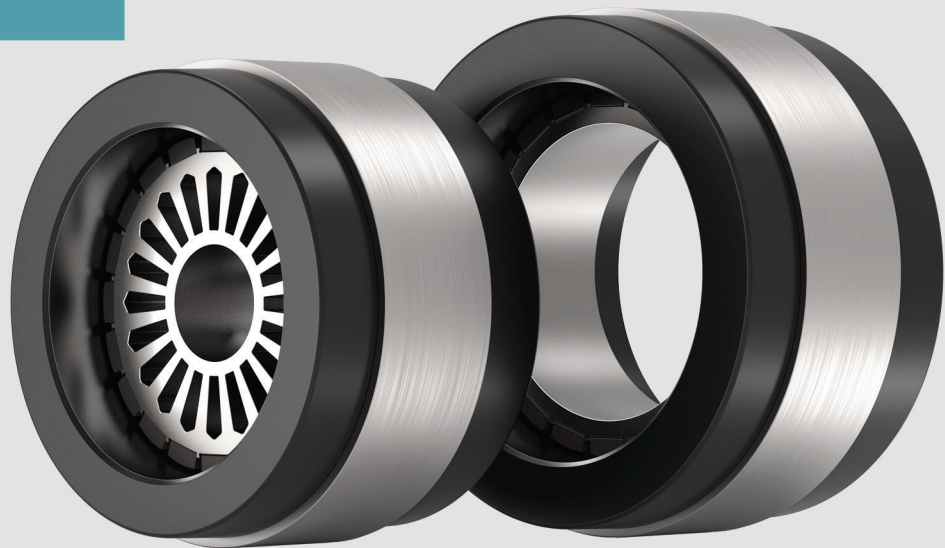

WITTENSTEIN cyber motor GmbH

Walter-Wittenstein-Straße 1
D-97999 Igersheim
Germany

Customer service

		✉	☎
Deutschland	WITTENSTEIN cyber motor GmbH	service@wittenstein.de	+49 7931 493-15900
Benelux	WITTENSTEIN BVBA	service@wittenstein.biz	+32 9 326 73 80
Brasil	WITTENSTEIN do Brasil	vendas@wittenstein.com.br	+55 15 3411 6454
中国	威腾斯坦（杭州）实业有限公司	service@wittenstein.cn	+86 571 8869 5856
Österreich	WITTENSTEIN GmbH	office@wittenstein.at	+43 2256 65632-0
Danmark	WITTENSTEIN AB	info@wittenstein.dk	+45 4027 4151
France	WITTENSTEIN sarl	info@wittenstein.fr	+33 134 17 90 95
Great Britain	WITTENSTEIN Ltd.	sales.uk@wittenstein.co.uk	+44 1782 286 427
Italia	WITTENSTEIN S.P.A.	info@wittenstein.it	+39 02 241357-1
日本	ヴァッテンシュタイン株式会社	sales@wittenstein.jp	+81-3-6680-2835
North America	WITTENSTEIN holding Corp.	technicalsupport@wittenstein-us.com	+1 630-540-5300
España	WITTENSTEIN S.L.U.	info@wittenstein.es	+34 93 479 1305
Sverige	WITTENSTEIN AB	info@wittenstein.se	+46 40-26 50 10
Schweiz	WITTENSTEIN AG Schweiz	sales@wittenstein.ch	+41 81 300 10 30
台灣	威騰斯坦有限公司	info@wittenstein.tw	+886 3 287 0191
Türkiye	WITTENSTEIN Güç Aktarma Sistemleri Tic. Ltd. Şti.	info@wittenstein.com.tr	+90 216 709 21 23

© WITTENSTEIN cyber motor GmbH 2024

This documentation is copyright protected.

WITTENSTEIN cyber motor GmbH reserves all rights to photo-mechanical reproduction, copying, and distribution by special processes (such as computers, file media, data networks), in whole or in part.

Subject to technical and content changes without notice.

Table of contents

1	Product presentation	3
1.1	Name plate	3
1.2	Amendment sheets	5
2	Intended use	6
2.1	Intended use	6
2.2	Application range	7
2.3	Standards and certificates	8
3	Safety instructions	12
3.1	Application and passing on of safety instructions	12
3.2	Personnel	13
3.3	Warning symbols and hazard classes	13
3.4	Hazard-related safety instructions	15
3.5	Minimizing risks	17
4	Transport and storage	18
4.1	Scope of delivery	20
5	Technical data	21
5.1	Definitions	21
5.2	Technical product data	27
5.2.1	Size 100	27
5.2.2	Size 112	30
5.3	Dimensional drawings	31
5.4	Type code	32
5.5	Installed components	34
5.5.1	Temperature sensor	34
5.5.2	Encoders	36
5.5.3	Brake	36
5.6	Accessories	36
6	Assembly	37
6.1	General information	37
6.2	Assembly of stators	38
6.2.1	Stators of size 100 and 112	38
6.3	Assembly of rotors	40
6.3.1	Rotors of size 100 and 112	41
6.4	Assembly of rotor/stator in the application	42
6.5	Electrical connection	43
7	Connection technology	44
7.1	General information	44
7.2	Safety instructions	44
7.3	Connection schematics	45
8	Startup and operation	48

8.1	General instructions for commissioning	48
8.2	Safety instructions	48
8.3	Preconditions and auxiliaries	49
8.4	General procedure for commissioning	51
9	Maintenance	51
9.1	Cleaning.....	52
9.2	Visual inspection.....	53
9.3	Disassembly	53
9.4	Disposal	55
10	Service & support.....	56

1 Product presentation

The servo motors of the cyber[®] kit line medium are versions of the stator and rotor subassembly without housing. The stator consists of a laminated core with the winding. The rotor is fitted with permanent magnets. The servo motors are designed for integration into the application. Particularly in moving axes, the servo motors offer a maximum of flexibility and are designed for implementation of various media thanks to their design with a large hollow shaft.



In connection with control units from the cyber[®] simco[®] drive series, intelligent drive solutions with high power density and outstanding functionality are created.

1.1 Name plate

The name plate serves for identification of the product and contains general information on the properties of the product. The name plate is provided with the product. The product bears a serial number for clear identification.

	<ul style="list-style-type: none"> • Attach the name plate or name plates at a suitable position of your machine according to applicable local regulations.
---	--

If the product complies with standards and guidelines requiring respective marking on the name plate, this marking is specified in the respective field of the name plate (see Tbl - 1 for stators or Tbl - 2 for rotors). The respective conformity applies for included products at correct assembly.

The technical data is specified on the name plate to ensure that the products have been assembled correctly with the required type of cooling if respective combinations of stator and rotor are used.

Products that include delivery of rotor and stator as pairs are fitted with a name plate referring to the delivered pair. Products that enable separate order of rotor and stator are respectively delivered with one name plate.

The data matrix code has the format C18x18 according to ECC200. It includes the address and code of the Service Portal.

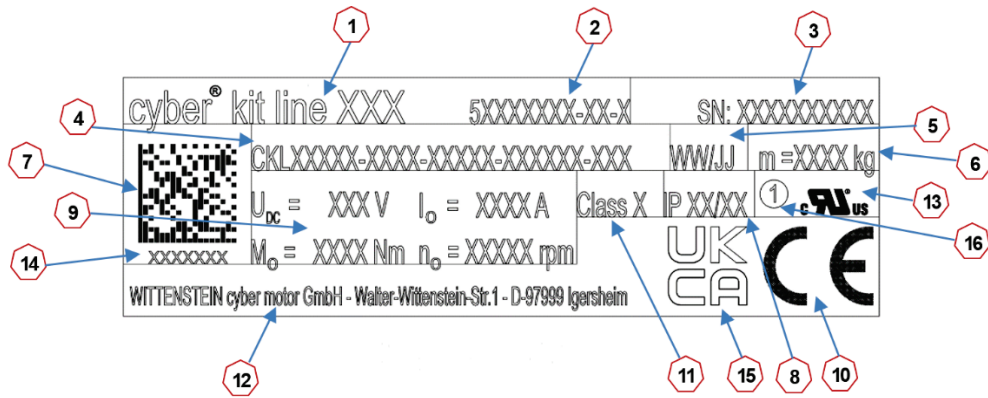

	Designation
1	Product designation
2	Material number
3	Serial number
4	Type code
5	Time of production: <i>WW Calendar week, YY Year</i>
6	Weight
7	Data matrix code
8	Protection class
9	Technical data: <i>U_{DC} Intermediate circuit voltage I_o Continuous stall current M_o Continuous stall torque n_o No-load speed</i>
10	Conformity: CE marking
11	Insulation class
12	Manufacturer designation
13	Conformity: UL marking (optional)
14	Service Portal code
15	Conformity: UKCA marking
16	Production plant

Tbl - 1 Stator name plate of cyber[®] kit line medium

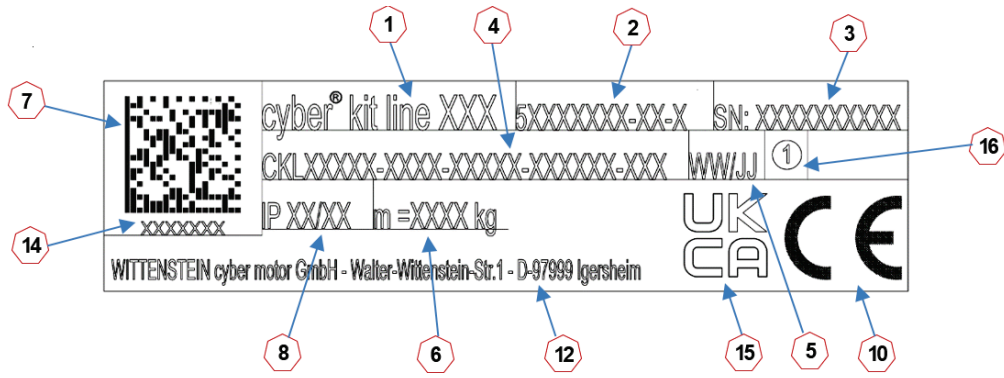

	Designation
1	Product designation
2	Material number
3	Serial number
4	Type code
5	Time of production: WW Calendar week YY Year
6	Weight
7	Data matrix code
8	Protection class
10	Conformity: CE marking
12	Manufacturer designation
14	Service Portal code
15	Conformity: UKCA marking
16	Production plant

Tbl - 2 Rotor name plate of cyber® kit line medium

1.2 Amendment sheets

If this manual is supplied with amendment sheets (e.g. for special applications), the information in the amendment sheets takes precedence and applies exclusively.

2 Intended use

The products of **WITTENSTEIN cyber motor** are developed and produced according to the latest standards.

The products may only be used in compliance with their intended use. If they are not used as intended, property damage and personal injury may be the consequence.

Before using the products, the following requirements must be observed to ensure use of the products as intended:

- Ensure that everybody working with one of the products has read and understood the applicable safety regulations and instructions on the intended use.
- Leave the products in their original condition. Do not change or manipulate the structure of the product.
- ① Software products must not be decompiled and source codes must not be changed.
- Do not subject the products to external force.
- Ensure that damaged or incorrect products are not installed or taken into operation.

2.1 Intended use

Only properly qualified and professionally trained personnel who are able to assess the safe condition of the product are allowed to work at the product. For example, this qualification is verified by the following points:

- Professional and/or technical training
- Knowledge of applicable standards and regulations
- Knowledge of accident prevention regulations and operating conditions
- Ability to recognize and assess potential danger

Electrical connection may only be realized by qualified personnel who are able to recognize, assess and prevent any potential electrical hazards.

All instructions in these project specifications, information on packaging and the product as well as the assembly instructions of your company must be observed at all times. If applicable, any local requirements must be observed.

WITTENSTEIN cyber motor GmbH is not informed about the installation conditions into your product. These project specifications highlight only the general conditions of use and limits of the building kit motor. It is the responsibility of your company to create and use the corresponding internal documents (e.g. assembly instructions, circuit diagrams etc.) on this basis.

The product may only be mounted with the intended attachment elements as described in the assembly instructions of your company.

In case of any differences between these project specifications, the instructions on the packaging, the instructions on the product, the local requirements and the assembly instructions of your company, clarify the correct approach with the responsible personnel at your company and notify the competent positions of the recognized differences.

2.2 Application range

The products of the cyber® kit line medium are exclusively intended for use in industrial systems as a rotary drive motor in machinery.

For control and monitoring of motors, connection of additional sensors and components may be required. The products may only be used with the accessories and attachments specified in these project specifications. These particularly include the housing for the stator or the shaft for the rotor. Components which are not specifically stated must not be mounted nor connected.

Operation is only allowed in compliance with explicitly stated configurations and combinations of components.

Before commissioning, every connected drive control unit must be parameterized for the motor to execute specific functions for the application.

The motors may only be used in compliance with the ambient conditions specified in these project specifications (e.g. temperature, protection class, cooling, etc.) and in the applications specified by your company.

Applicable ambient conditions during operation of products:

- IEC 60721-3-3, class 3K3 with adjustment of the low air temperature from +5 °C to +0 °C and of the relative humidity from 85% to 95%.
- IEC 60721-3-3, class 3B1
- IEC 60721-3-3, class 3C1
- IEC 60721-3-3, class 3S1
- IEC 60721-3-3, class 3M8

Tbl - 3 contains an excerpt of the ambient conditions during operation for the products.

Ambient conditions during operation			
Property	Value	Standard	Class
Temperature range	+0 °C ... +40 °C ^a	IEC 60721-3-3	3K3
Relative humidity	5 % ... 95 % ^a	IEC 60721-3-3	3K3
Absolute humidity	1 g/m ³ ... 25 g/m ³	IEC 60721-3-3	3K3
Rate of temperature change	0.5 °C/min	IEC 60721-3-3	3K3
Max. vibration load (9 – 200 Hz)	50 m/s ^{2 a}	IEC 60721-3-3	3M8
Max. axial shock load (6 ms)	250 m/s ^{2 a}	IEC 60721-3-3	3M8
Max. radial shock load (6 ms)	250 m/s ^{2 a}	IEC 60721-3-3	3M8

a: Values adjusted compared to standard

Tbl - 3 Excerpt of ambient conditions during operation

The protection class is indicated by the abbreviation IP (International Protection) and two numbers stating the degree of protection. The first number describes the degree of protection against contact and ingress of foreign objects, the second number describes the degree of protection against water.

For stator and rotor of the cyber® kit line medium, protection class IP00 according to IEC 60529 applies. For this reason, observe the assembly instructions of your company to protect the products with suitable covers or seals. If the protection class is not observed, irreparable product damage may be the consequence. Definition, checking and implementation of suitable measures is within the responsibility of the operating company.

Power converted to heat is dissipated via neighboring components. For this reason, products must only be operated if sufficient power dissipation is ensured. The cooling system and materials used must be designed accordingly. Please observe that heat can be dissipated as well as introduced via attached components.

2.3 Standards and certificates

In these project specifications, German, European and international technical standards are mentioned. Standard documents and standard sheets are subject to copyright protection. As required, please contact the authorized distributors.

All products of the cyber® kit line medium comply with the following standards and regulations if applicable for the products:

- IEC 60034 Rotating electrical machines
- 2014/35/EU Low Voltage Directive
- 2006/42/EC Machinery Directive
- 2011/65/EU RoHS Directive
- 640/2009 Regulation on Ecodesign Directive
- 2014/30/EU EMC Directive

The product complies with the EU directives specified in the respective EU declaration of conformity and therefore bears the CE mark. The EU declarations of conformity or the declarations of incorporation are illustrated in the following figures for the respective products depending on the type code.

CKLCxxxK-xxxC-xxxBx-xx0xSx-NNN	cyber® kit line
	
<h2 style="margin: 0;">EU-Konformitätserklärung</h2> <h3 style="margin: 0;">EU Declaration of Conformity</h3>	
<p>Wir / We Anschrift / Adress</p>	<p>WITTENSTEIN cyber motor GmbH Walter-Wittenstein-Straße 1 D-97999 Igersheim / Germany Tel: +49(0)7931 - 493-15800 Fax: +49(0)7931 - 493-10905 E-mail: info@wittenstein-cyber-motor.de</p>
<p>erklären hiermit in alleiniger Verantwortung, dass die Erzeugnisse / declare under our sole responsibility, that the products Bezeichnung / Designation</p>	
<p>cyber® kit line</p>	
<p>Typ / Type</p>	<p>CKLCxxxK-xxxC-xxxBx-xx0xSx-NNN</p>
<p>konform sind zu der EU-Richtlinie / 2011/65/EU</p>	<p>are conform with the EU directive Beschränkung der Verwendung bestimmter gefährlicher Stoffe in Elektro- und Elektronikgeräten (RoHS-Richtlinie) <i>Restriction of the use of certain hazardous substances in electrical and electronic equipment (RoHS directive)</i></p>
<p>und die einschlägigen Bestimmungen dieser EU-Richtlinie erfüllen. / and fulfill the relevant provisions of this EU directive.</p>	
<p>Die Erzeugnisse tragen das CE-Zeichen. / The products bear the CE-marking.</p>	
<p style="writing-mode: vertical-rl; transform: rotate(180deg);">1000154995-EGOL-000</p>	<p>Igersheim, den 08.11.2023 Ort und Datum der Ausstellung / Place and date of declaration</p>
	<p>Dr. Edgar Olbrant Geschäftsführer / General Manager WITTENSTEIN cyber motor GmbH</p> 

Fig. 2-1 EU declaration of conformity of cyber® kit line medium, cooling type "C," voltage class "B"

CKLCxxxK-xxxC-xxxBx-xxDxSx-NNN

cyber® kit line

Die Erzeugnisse sind außerdem konform zu der EU-Richtlinie / *Additionally the products are conform with the EU directive*
2011/65/EU **Beschränkung der Verwendung bestimmter gefährlicher Stoffe in Elektro- und Elektronikgeräten (RoHS-Richtlinie)**
Restriction of the use of certain hazardous substances in electrical and electronic equipment (RoHS directive)

und sind mit der CE-Kennzeichnung versehen. Details hierzu siehe EU-Konformitätserklärung. / *and are equipped with the CE marking. Details can be seen from the EU Declaration of Conformity.*

Die speziellen technischen Unterlagen gemäß Anhang VII Teil B der Maschinenrichtlinie 2006/42/EG wurden erstellt. Wir verpflichten uns, diese Unterlagen einzelstaatlichen Stellen auf begründetes Verlangen in Papierform oder elektronischer Form zu übermitteln. Unsere gewerblichen Schutzrechte bleiben hiervon unberührt. / *The relevant technical documentation is compiled in accordance with part B of Annex VII of the machinery directive 2006/42/EC. We undertake to transmit, in response to a reasoned request by the national authorities, relevant information on the product in written or electronic form. Our intellectual property rights are not prejudiced by this transmission.*

Die Erzeugnisse dürfen erst dann in Betrieb genommen werden, wenn gegebenenfalls festgestellt wurde, dass die Maschine, in die das Erzeugnis eingebaut werden soll, den Bestimmungen der Maschinenrichtlinie 2006/42/EG entspricht. / *The products must not be put into service until the final machinery into which it is to be incorporated has been declared in conformity with the provisions of the machinery directive 2006/42/EC, where appropriate.*

1000154995-601-000

Igersheim, den 08.11.2023
 Ort und Datum der Ausstellung / *Place and date of declaration*

Dr. Edgar Olbrant 
 Geschäftsführer / *General Manager*
 WITTENSTEIN cyber motor GmbH

Fig. 2-2 EU declaration of conformity of cyber® kit line medium, cooling type "C," voltage class "B"



EU-Konformitätserklärung EU Declaration of Conformity

Wir / We WITTENSTEIN cyber motor GmbH
 Anschrift / Address Walter-Wittenstein-Straße 1
 D-97999 Igersheim / Germany
 Tel: +49(0)7931 - 493-15800
 Fax: +49(0)7931 - 493-10905
 E-mail: info@wittenstein-cyber-motor.de

erklären hiermit in alleiniger Verantwortung, dass die Erzeugnisse / *declare under our sole responsibility, that the products*

Bezeichnung / Designation

cyber® kit line

Typ / Type

CKLCxxxK-xxxC-xxxTx-xx0xSx-NNN

konform sind zu den EU-Richtlinien /	<i>are conform with the EU directives</i>
2014/35/EU	Elektrische Betriebsmittel zur Verwendung innerhalb bestimmter Spannungsgrenzen (Niederspannungsrichtlinie) <i>Electrical equipment designed for use within certain voltage limits (low voltage directive)</i>
2011/65/EU	Beschränkung der Verwendung bestimmter gefährlicher Stoffe in Elektro- und Elektronikgeräten (RoHS-Richtlinie) <i>Restriction of the use of certain hazardous substances in electrical and electronic equipment (RoHS directive)</i>

und die einschlägigen Bestimmungen dieser EU-Richtlinien erfüllen. / *and fulfill the relevant provisions of these EU directives.*
 Die Erzeugnisse erfüllen die den wesentlichen Anforderungen der oben genannten EU-Richtlinien entsprechenden Bestimmungen der harmonisierten Normen / *The products fulfill the essential requirements of the EU directives mentioned above by fulfilling the corresponding requirements of the harmonized standards*

EN 60034-1:2010	Drehende elektrische Maschinen - Teil 1: Bemessung und Betriebsverhalten <i>Rotating electrical machines - Part 1: Rating and performance</i>
EN 60034-8:2007 + A1:2014	Drehende elektrische Maschinen — Teil 8: Anschlussbezeichnungen und Drehsinn <i>Rotating electrical machines - Part 8: Terminal markings and direction of rotation</i>
EN 60204-1:2006 + A1:2009	Sicherheit von Maschinen - Elektrische Ausrüstung von Maschinen - Teil 1: Allgemeine Anforderungen <i>Safety of machinery - Electrical equipment of machines - Part 1: General requirements</i>

und zusätzlich der Norm / *and additionally of the technical standard*
DIN VDE 0100-600:2017-06 **Errichten von Niederspannungsanlagen - Teil 6: Prüfungen**
Low-voltage electrical installations - Part 6: Verification

Die Erzeugnisse tragen das CE-Zeichen. / *The products bear the CE-marking.*

1000154996-001-000

Igersheim, den 08.11.2023
 Ort und Datum der Ausstellung / Place
 and date of declaration

 Dr. Edgar Olbrant
 Geschäftsführer / *General Manager*
 WITTENSTEIN cyber motor GmbH

Fig. 2-3 EU declaration of conformity of cyber® kit line medium, cooling type "C," voltage class "T"

Products with the UL mark are certified according to the following "Standard(s) for Safety":

- Motors, certification for USA:
 - o UL 1004-1: Standard for Rotating Electrical Machines – General Requirements
 - o UL 1004-6: Standard for Servo and Stepper Motors
 - o UL 840: Standard for Safety Insulation Coordination including Clearances and Creepage Distances for Electrical Equipment
- Motors, certification for Canada:
 - o C22.2, No. 100: Standard for Motor and Generators
- Control units, certification for USA:
 - o UL 61800-5-1: Standard for Adjustable Speed Electric Power Drive Systems, Safety Requirements – Electrical, Thermal and Energy
- Control units, certification for USA and Canada:
 - o C22.2, No. 274: Standard for Adjustable Speed Drives
- Insulation system:
 - o UL 1446: Standard for Systems of Insulating Materials – General
- Safety:
 - o UL 746C: Standard for Safety. Polymeric Materials – use in Electrical Equipment

3 Safety instructions

3.1 Application and passing on of safety instructions

Do not install and commission the product before having thoroughly read all provided documents. These safety instructions and all user instructions must be read each time before working with the product. If the product is sold, borrowed and/or passed on in any other way, these safety instructions must also be passed on as part of the project specifications in the national language of the user.

	⚠ WARNING
	Incorrect handling of this product, non-compliance with the warnings in this document or unauthorized modification of safeguards can lead to damage, injury, electric shock or even death.

The safety instructions and any measures derived by your company must be included by your company into the assembly and installation instructions after carrying out a risk assessment. Inform yourself about the safety instructions already during project planning. Also observe any national regulations and include them into the assembly and installation instructions.

In addition to the safety instructions mentioned in these project specifications, generally applicable and local regulations on prevention of accidents and environmental protection must be observed. If necessary, use suitable personal protective equipment.

3.2 Personnel

Work on the servo motor may only be carried out by personnel with the respective described qualifications.











- **Logistic personnel** are to be qualified to handle lifting gear and carry out safe transport of high-quality machine components without any damage and ensuring their proper storage.
- **Installation personnel (mechanical engineers)** are to be qualified to carry out professional tightening connections and fit components as well as connection of coolant lines.
- **Installation personnel (electrical engineers)** are to be qualified to carry out connections for power and signal inputs.
- **Designers** are to be qualified to design products correctly and safely (both electrical and mechanical).
- **Maintenance engineers** are to be qualified to carry out professional maintenance and repairs as well as to identify critical defects on the product.

3.3 Warning symbols and hazard classes

Warning instructions are structured in the following hazard classes in compliance with ANSI Z535 and ISO 3864:





	⚠ DANGER
	This signal word indicates an imminent danger that will cause serious injuries or even death.
	⚠ WARNING
	This signal word indicates a potential hazard that could cause serious injuries and even death.
	⚠ CAUTION
	This signal word indicates a potential hazard that could cause minor or serious injuries.
	NOTICE
	This signal word indicates a potential hazard that could lead to property damage.
	A note without a signal word indicates application hints or especially important information for handling the product.



The following warning symbols are used in these project specifications to indicate hazards in connection with the safety instructions. Observe the warnings and use them for preparation of the assembly and operating manual:

Warning symbol	Hazard	Warning symbol	Hazard
	General danger		Hot surface
	Suspended loads		Entanglement
	Magnetic field		Electric voltage
	Crushing		Electrostatically sensitive device
	No persons with pacemakers		Information
	Explosion		

Tbl - 4 Warning symbols of safety instructions

3.4 Hazard-related safety instructions

	<p style="text-align: center;">⚠ DANGER</p> <p>Faulty electrical connections or unapproved, current-carrying components can cause serious injuries and even death.</p> <ul style="list-style-type: none"> • Ensure that electrical connections are only established by qualified personnel. • Observe valid standards and directives. • Carry out connection work only with suitable tools. • Immediately replace damaged cords or plugs.
	<p style="text-align: center;">⚠ DANGER</p> <p>Electrically live parts may result in electric shocks if touched and can cause serious injuries and even death. Electrical work performed in damp areas may result in electric shocks and can cause serious injuries and even death.</p> <ul style="list-style-type: none"> • Ensure that electrical connections are only established by qualified personnel. • Observe valid standards and directives. • Carry out connection work only with suitable tools. • Observe the general installation and safety regulations for work at electrical systems. • Before accessing electrical parts with voltages exceeding 50V, disconnect the product from the voltage supply. Secure the product against reactivation. • Do not make contact with electrical connections of the product while it is activated under any circumstances.
	<p style="text-align: center;">⚠ WARNING</p> <p>When the shaft is still turning or when the product is driven externally (generator operation), voltage is induced. This can cause lethal current surges.</p> <ul style="list-style-type: none"> • Ensure that connections and connectors are not open and unprotected against contact. • Do not make contact with electrical connections of the product while it is activated under any circumstances.
	<p style="text-align: center;">⚠ WARNING</p> <p>Connecting or disconnecting the power and signal supply lines <i>under voltage</i> can lead to machine damage, serious injury or even death.</p> <ul style="list-style-type: none"> • Make sure that the product and the connections of the electronics (power and signal) are in a voltage-free state before connecting. • Observe any discharge time of your components.

	<h2 style="text-align: center;">⚠ WARNING</h2>
	<p>Components equipped with permanent magnets and components that emit magnetic fields can influence/impede the function of active medical implants (e.g. pacemakers, defibrillators). This can lead to serious injuries or even death.</p> <ul style="list-style-type: none"> • Assembly and storage areas must not be accessed by personnel with active body implants, which may be affected by permanent magnetic fields. • Include the warning into the assembly instructions of your company. • Make sure that the warning remains at the product as long as a hazard exists.
	<h2 style="text-align: center;">⚠ WARNING</h2>
	<p>Moving components on the product can pull in or crush parts of the body or eject objects and cause serious injuries and even death. A wrong direction of rotation or direction of movement may result in serious injury or death.</p> <ul style="list-style-type: none"> • Remove objects and tools from the motor before putting it into operation. • Make sure that all components at the product are secured according to the assembly instructions of your company. • Keep a sufficient distance to moving machine components when the motor is running. • Secure the machine against restarting and unintentional movement during assembly and maintenance work. • Before and during startup, ensure that the motor has the correct direction of rotation. • Avoid collisions (e.g. moving against an end stop). • Check the direction of rotation in a slow motion, ideally by limiting the current and torque in a secured danger area.
	<h2 style="text-align: center;">⚠ CAUTION</h2>
	<p>During the mechanical assembly of the product onto the application, handling errors can lead to serious crushing injuries as well as to damage to the product or the application.</p> <ul style="list-style-type: none"> • Secure the machine against restarting and unintentional movement during assembly and maintenance work. • Have all mechanical assembly and maintenance work carried out by qualified personnel only. • Only use suitable tools for assembly and maintenance work.

	<h3>⚠ CAUTION</h3>
	<p>During the mechanical assembly of kit motors, the attraction forces of the magnets can cause serious crushing injuries and damage to the motor or the application.</p> <ul style="list-style-type: none"> • Avoid unwanted movement of components of the kit motors by suitable auxiliaries for assembly. • Have all mechanical assembly and maintenance work carried out by qualified personnel only. • Only use suitable non-magnetic tools for assembly and maintenance work.

	<h3>⚠ CAUTION</h3>
	<p>Hot surfaces at the product (e.g. housing, motor housing) can cause serious injuries.</p> <p>During and after operation, the temperatures of the products and surrounding components can exceed 60 °C (140 °F) depending on the operating conditions and the cooling.</p> <ul style="list-style-type: none"> • Let the product cool down for a sufficient period after switching it off. • When working with hot surfaces, always wear protective gloves. • For specific applications, plan suitable measures to prevent burning injuries. • Check for your application whether safety measures and warnings are required.

	<h3>NOTICE</h3>
	<p>If present, the temperature sensors and rotor position encoders, particularly Hall effect sensors and encoders, can be damaged by electrostatic discharge.</p> <ul style="list-style-type: none"> • Carry out the work in an ESD-protected work environment and with suitable personal protective equipment. • Do not remove ESD safeguards from the connections before they are established.

	<p>When using the product, additional standards may need to be observed (e.g. DIN EN 61800 "Adjustable speed electrical power drive systems").</p>
---	--

3.5 Minimizing risks

The building kit motor is developed and produced according to the latest standards.

The responsibility for the intended use of the building kit motor and minimizing risks on the overall product lies with the manufacturer of this overall product.

	<p>For minimizing risks on the overall product, we recommend the following approach to you:</p> <ul style="list-style-type: none"> • Prepare an application-specific risk assessment in the form of a FMEA, for example. If necessary, introduce measures for minimizing risks.
---	---

4 Transport and storage

The products of the cyber[®] kit line medium are delivered in a cardboard outer packaging. Outer packaging and packaging units on pallets are secured with straps.

	<h3>⚠ CAUTION</h3>
	<p>Risk of injury when disengaging the straps due to uncontrolled movements when cutting open the cardboard boxes.</p> <ul style="list-style-type: none"> • Carefully disengage the straps and keep sufficient safety distance. • Use suitable tools, e.g. safety cutter and personal protective equipment, when cutting open the cardboard boxes.

Inside the outer packaging, the products are protected by cardboard boxes, plastic enclosures, foam, VCI paper, VCI pad, desiccant bag, ESD foam pad and/or ESD bags.

- Dispose of the packaging materials at the recycling sites intended for this purpose and observe applicable national regulations.

Before shipping, the products of the cyber[®] kit line medium are tested in a standardized process and separate high-voltage testing by the customer is not required. The products may be damaged if the high-voltage test is repeated.

	<h3>NOTICE</h3>
	<p>Risk of destruction of motor components due to incorrect high-voltage testing.</p> <ul style="list-style-type: none"> • Observe the specifications on high-voltage testing in IEC 60034. • Avoid repeating tests.

The overall scope of delivery is described in the delivery or shipping note and the contents may be distributed across several packages. Every package can be identified by the shipping sticker on its outside.

- Check the received goods pursuant to chapter 4.1.
 - Note the weight of the product and use an appropriate transport device.
- ① Information on the weight of the product can be found on the name plate.

	⚠ CAUTION
	<p>Risk of crushing and injury due to the permanent magnets of the rotor.</p> <ul style="list-style-type: none"> • Be careful when handling the rotors. • Remove any moving, ferromagnetic objects or secure them against intended movements.

For protection of the product, **WITTENSTEIN cyber motor** recommends transporting the product to its intended location of installation inside the product packaging of **WITTENSTEIN cyber motor**.

	NOTICE
	<p>Damage due to incorrect handling.</p> <ul style="list-style-type: none"> • Have the product transported in its original packaging and by qualified personnel. • Observe the ambient conditions during transport and storage of the products.

The ambient conditions to be observed for **transport** of the products inside the packaging of **WITTENSTEIN cyber motor** are as follows:

- IEC 60721-3-3, class 3K6
- IEC 60721-3-3, class 3B1
- IEC 60721-3-3, class 3C1
- IEC 60721-3-3, class 3S2
- IEC 60721-3-3, class 3M2

Always store the product in horizontal position in the original packaging. The ambient conditions must be dry and clean. Store the product for a maximum of 2 years. For storage logistics, we recommend the "first in – first out" method.

The ambient conditions to be observed for **storage** of the products inside the packaging of **WITTENSTEIN cyber motor** are as follows:

- IEC 60721-3-3, class 3K3
- IEC 60721-3-3, class 3B1
- IEC 60721-3-3, class 3C1
- IEC 60721-3-3, class 3S1
- IEC 60721-3-3, class 3M1

4.1 Scope of delivery

The overall scope of delivery is listed on the delivery note. The stator and rotor each have individual name plates (see chapter 1.1) and an operating manual in multiple languages enclosed.

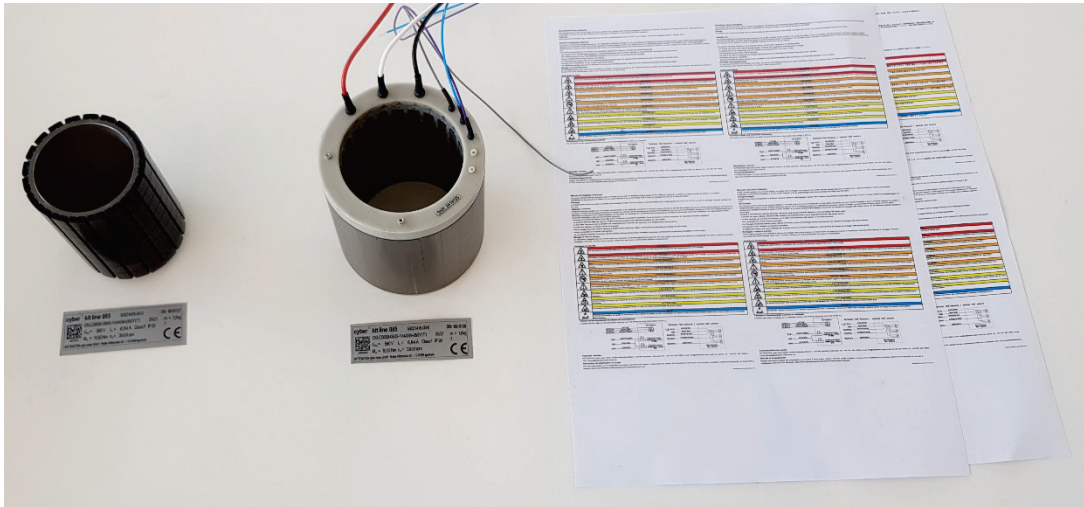



Fig. 4-1 Scope of delivery of the cyber[®] kit line medium

	<p>Check the received goods:</p> <ul style="list-style-type: none"> • Check the received scope of delivery for completeness • After receipt, compare the delivered products with the order. • Immediately notify the carrier, the insurance company or WITTENSTEIN cyber motor GmbH in writing of any deviations, missing parts or damage.
--	--

<h3>NOTICE</h3>	
	<ul style="list-style-type: none"> • Visual abnormalities such as discoloration, adhesive residue, etc. are procedural effects and do not represent defects since they in no way impair product function.

5 Technical data

5.1 Definitions

The products of the cyber[®] kit line medium are documented according to the test procedure and the measuring procedure of IEC 60034-1. The specified technical data refers to the operating modes S1 (continuous operation) and S6 (periodic operation), respectively with the specified cooling type. The determined values are effective values according to IEC 60034-1 unless stated otherwise. The reference value is the intermediate circuit voltage U_{DC} specified in the product data.

Designation	Symbol	Unit	Explanation
Continuous torque	M_{S1}	Nm	Admissible continuous torque of the motor depending on the speed.
Continuous power	P_{S1}	W	Admissible continuous power of the motor depending on the speed.
Intermediate circuit voltage	U_{DC}	V	DC voltage at intermediate circuit
Torque constant	k_m	Nm/A	Torque constant calculated from torque and effective value of the current.
Voltage constant	k_e	Vs	Voltage constant calculated from the peak value of the voltage induced between the two phases and speed n at externally driven motor.
Motor constant	k_{mot}	Nm/ \sqrt{W}	Efficiency factor calculated from torque and power dissipation.
Ambient temperature	ϑ_u	°C	Maximum permissible ambient temperature without reduced performance (maximum inlet temperature of the coolant for liquid cooling).
Maximum winding temperature	ϑ_{max}	°C	Maximum admissible winding temperature.
Heat transfer resistance	R_{th}	K/W	Heat transfer resistance not to be exceeded for discharge of thermal losses.
Max. power	P_{max}	W	Maximum power for short-term operation.
Maximum torque	M_{max}	Nm	Maximum torque at maximum current I_{max} .
Maximum current	I_{max}	A	Maximum current, effective value
Continuous stall torque	M_0	Nm	Continuously permissible torque at motor standstill.
Continuous stall current	I_0	A	Continuously permissible current (effective value) leading to the permissible heating of the winding.
No-load speed	n_0	min ⁻¹	Maximum speed that is reached load-free without field-weakening when operated with U_{DC} .
Rated power	P_n	W	Continuously permissible power at speed n_n .

Designation	Symbol	Unit	Explanation
Rated torque	M_n	Nm	Continuously permissible torque at speed n_n .
Rated current	I_n	A	Continuously permissible current (effective value) at speed n_n .
Rated speed	n_n	min^{-1}	Speed up to which M_n is continuously specified.
Connection resistance	R_{tt}	Ω	Resistance between two phases at 20°C.
Connection inductance	L_{tt}	mH	Inductance between two phases at 20°C.
Electrical time constant	τ_e	ms	Electrical time constant
No. of pole pairs	p		Number of pole pairs of motor.
Mass moment of inertia	J	kgm^2	Mass moment of inertia of rotor.
Minimum flow	Q	l/min	Required minimum flow rate of water coolant medium.
Weight	m	kg	Weight of rotor and stator.
Mass moment of inertia of encoder channel	J_{enc}	kgm^2	Mass moment of inertia of optional encoder channel.
Encoder channel weight	m_{enc}	kg	Weight of optional encoder channel.
Continuous torque	M_{S1}	Nm	Admissible continuous torque of the motor depending on the speed.
Continuous power	P_{S1}	W	Admissible continuous power of the motor depending on the speed.

Tbl - 5 Explanation of electromechanical parameters

The products of the cyber[®] kit line medium primary consist of the components stator and rotor. The technical product data apply for use of the respective rotor with the respective stator and for correct assembly of components. Stator and rotor components belonging together can be identified by the specification of the type code in version "CKLC..." (see chapter 5.4) and the resolution of the type code in the components stator and rotor.

	⚠ WARNING
	<p>Derating of the continuous current while the motor is stationary In applications in which the motor is permanently energized while stationary, uneven, quicker heating of the motor occurs.</p> <ul style="list-style-type: none"> • Make sure the continuous stall current is reduced by 30% to prevent the motor from overheating.

The sample curve is an example for illustration of the operating behavior of the cyber® kit line medium according to technical parameters.

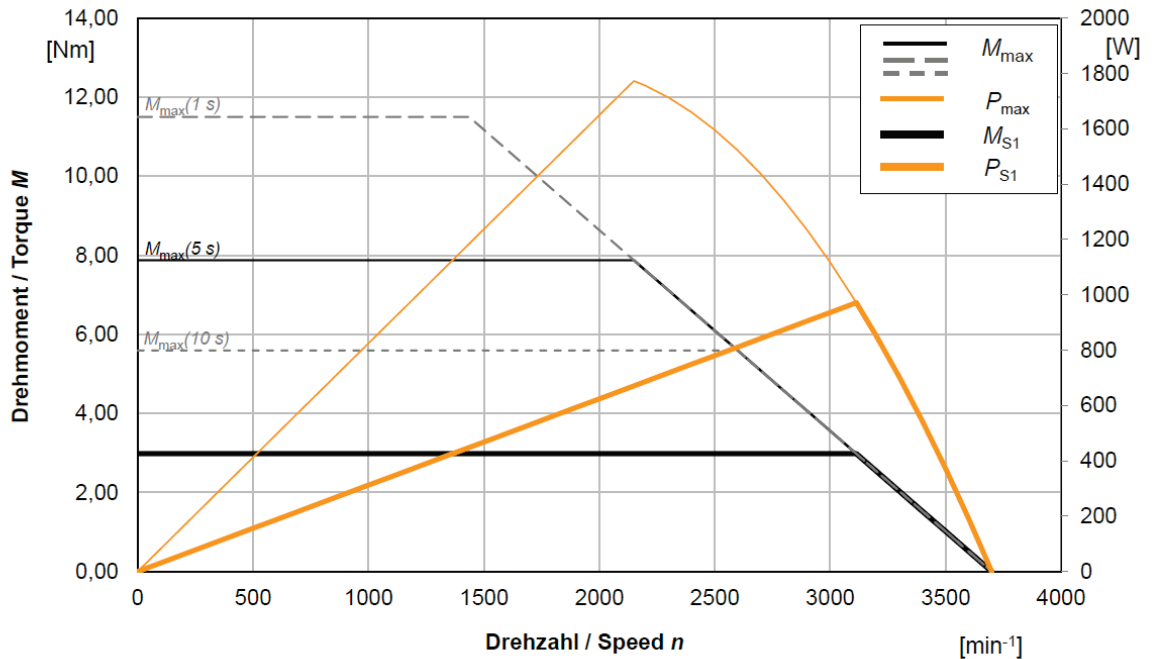

The maximum torque M_{max} is available up to a defined speed. With increasing speed, the maximum torque is reduced due to the speed-dependent induced voltage of the motor. This leads to a reduction in torque down to the no-load speed n_0 . Up to the torque M_{S1} , the torque output is continuous at the specified cooling type. Accordingly, the maximum power P_{max} is available at the respective speed and the power is output by the motor up to the continuous power P_{S1} .

The motor curves specified in chapter 5.2 apply for the use of respective combinations of stator and rotor. The maximum speed specified in the motor curve corresponds to the admissible maximum speed.

	<h3>⚠ CAUTION</h3>
	<p>If the maximum speed is exceeded, flying parts can lead to injuries.</p> <ul style="list-style-type: none"> • Make sure that the maximum speed of the motor is not exceeded. • Parameterize the admissible maximum speed of the product in your drive control unit.

The specified technical data apply according to IEC 60034-1 for installation heights of up to 1000 m above sea level. At installation heights of more than 1000 m above sea level, the performance data is reduced by 13% / 1000 m for cooling type "C" or 2.5% / 1000 m for cooling type "L". The maximum admissible installation height of motors with power connection "A" is 5000 m above sea level. For the use of connectors, sockets or terminal boxes, the installation height may be limited. Regarding the installation height and its impact, not only observe the motor but the entire drive system.

For products with cooling type "L," the minimum flow is specified for a temperature increase of 5 °C for the cooling medium water between coolant inlet and coolant outlet. If the flow is deviating, linear conversion of the temperature increase is possible.

	⚠ CAUTION
	<p>An electrical breakdown due to the maximum intermediate circuit voltage U_{DC} being exceeded can lead to injuries (electric shock).</p> <ul style="list-style-type: none"> • When using the product, do not exceed the maximum intended intermediate circuit voltage. • For 48 V versions, this is max. 72 V • For 560 V versions, this is max. 600 V • For 750 V versions, this is max. 750 V

If the product is operated with a current exceeding the continuous stall current, the power dissipation in the product and the temperature are increased. Depending on the installation situation, sufficient discharge of thermal energy is not always ensured. For this reason, limit the duration for which the product is operated with a current exceeding the continuous stall current - and particularly the maximum current.

	NOTICE
	<p>Extended operation with high current can lead to inadmissible heating of the product.</p> <ul style="list-style-type: none"> • Limit the duration for which the product can be operated with a current exceeding the permanently admissible current depending on the current rating, the installation situation and the thermal connection. At a maximum winding temperature of 40 °C, operation with maximum current is possible for up to 10.0 s in typical applications. • If an exact calculation is not available, limit the duration of the maximum current to 5.0 s.

The geometrical product data in figure 5-1 offer a quick overview of the dimensions of the products of the cyber® kit line medium. For exact dimensions and tolerances, please refer to the dimensional drawings in chapter 5.3.

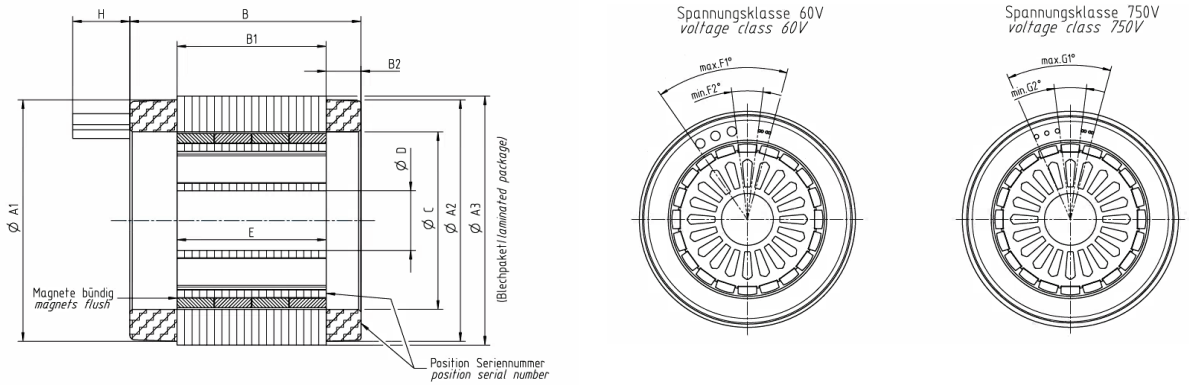

Variant 1: small inner diameter "A"

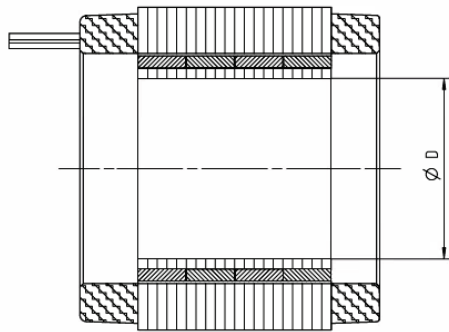

Variant 2: large inner diameter "E"

Fig. 5-1 Description of geometrical characteristics for size 100

Designation	Symbol	Unit	Explanation
Potting outer diameter B	A1	mm	Outer diameter of the stator measured at the potting at cable side / B side
Potting outer diameter A	A2	mm	Outer diameter of the stator measured at the potting at counter side / A side
Outer diameter of stator	A3	mm	Outer diameter of the stator measured at the laminated core
Stator length	B	mm	Length of the stator measured in axial direction without electrical connections
Length of laminated core	B1	mm	Length of the laminated core of the stator measured in axial direction
Height of winding head A-side	B2	mm	Height of winding head on A side
Stator inner diameter	C	mm	Inner diameter of stator
Rotor inner diameter	D	mm	Inner diameter of rotor
Rotor length	E	mm	Length of the rotor
Angle	G	Degrees [°]	Angular area where the electrical connections are established
Wire length	H	mm	Length of electrical connections (wires)
Wire cross-section	-	mm ²	Cross-section of electrical connections (wires), data: Power / Neutral point / PE conductor // Temperature sensor

Tbl - 6 Description of geometrical characteristics for size 100

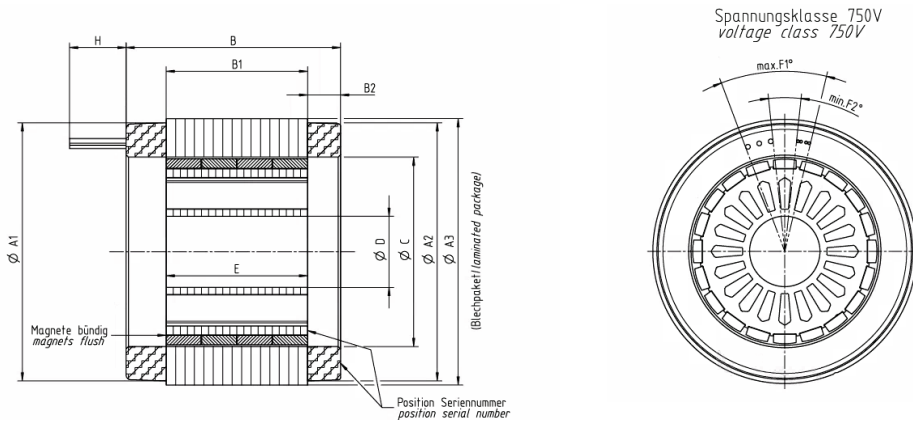

Variant 1: small rotor inner diameter "A"

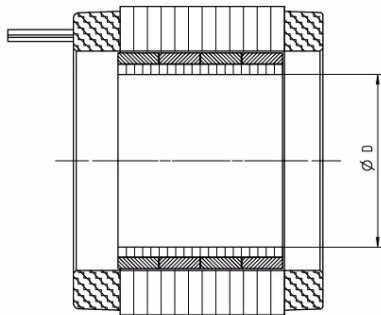

Variant 2: large inner diameter "E"

Fig. 5-2 Description of geometrical characteristics for size 112

Designation	Symbol	Unit	Explanation
Potting outer diameter B	A1	mm	Outer diameter of the stator measured at the potting at cable side / B side
Potting outer diameter A	A2	mm	Outer diameter of the stator measured at the potting at counter side / A side
Outer diameter of stator	A3	mm	Outer diameter of the stator measured at the laminated core
Stator length	B	mm	Length of the stator measured in axial direction without electrical connections
Length of laminated core	B1	mm	Length of the laminated core of the stator measured in axial direction
Height of winding head A-side	B2	mm	Height of winding head on A side
Stator inner diameter	C	mm	Inner diameter of stator
Rotor inner diameter	D	mm	Inner diameter of rotor
Rotor length	E	mm	Length of the rotor
Angle	G	Degrees [°]	Angular area where the electrical connections are established
Wire length	H	mm	Length of electrical connections (wires)
Wire cross-section	-	mm ²	Cross-section of electrical connections (wires), data: Power / Neutral point / PE conductor // Temperature sensor

Tbl - 7 Description of geometrical characteristics for size 112

5.2 Technical product data

The values and data presented here serve the exclusive purpose of general comparison. Neither are changes and tolerances illustrated, nor are you subject to a modification service.

- ① You will find binding values, data and dimensions in the dimensional sheets and characteristic curves, as amended.

5.2.1 Size 100

Version	Size – Length		100-030		100-060		100-120	
	Inner diameter		E	A	E	A	E	A
Potting outer diameter B	A1	mm	97					
Potting outer diameter A	A2	mm	97					
Stator outer diameter	A3		100					
Stator length	B	mm	63		93		153	
Length of laminated core	B1	mm	30		60		120	
Height of winding head on A side	B2	mm	14					
Inner diameter of stator	C	mm	71.3					
Rotor inner diameter	D	mm	24	56	24	56	24	56
Rotor magnet length	E	mm	≤ 30		≤ 60		≤ 120	
Angle	F1	Degree	60					
Angle	F2	Degree	13.9					
Angle	G1	Degree	43					
Angle	G2	Degree	13.9					
Wire length	H	mm	300					
Power wire cross-section	-	mm ²	60 V: 4 mm ² 750 V: 0.5 mm ²					
Power wire diameter (incl. sheath)	-	mm	60 V: 4.2 mm 750 V: 2.53 mm ²					
Signal wire cross-section	-	mm ²	0.23 mm ²					
Signal wire diameter (incl. sheath)	-	mm	max. 1.3 mm					

Tbl - 8 Geometrical characteristics for size 100

Version	Size – Length - Voltage class		100-030-B		100-060-B		100-120-B	
	Inner diameter		E	A	E	A	E	A
Intermediate circuit voltage	U_{DC}	V	48					
Torque constant	k_m	Nm/A	0.16		0.19		0.25	
Voltage constant	k_e	Vs	0.13		0.15		0.21	
Motor constant	k_{mot}	Nm/ \sqrt{W}	0.54		0.8		1.23	
Ambient temperature	ϑ_u	°C	40					
Maximum winding temperature	ϑ_{max}	°C	155					
Heat transfer resistance	R_{th}	K/W	0.81		0.65		0.47	
Max. power	P_{max}	W	3570		5275		8702	
Maximum torque	M_{max}	Nm	16		32.5		64.2	
Maximum current	I_{max}	A	120		200		300	
Continuous stall torque	M_0	Nm	5.2		8.4		15.2	
Continuous stall current	I_0	A	33.4		49.4		61.5	
No-load speed	n_0	min ⁻¹	3565		2990		2226	
Rated power	P_n	W	1425		2228		2583	
Rated torque	M_n	Nm	4.2		7.6		12	
Rated current	I_n	A	28.0		39.1		50.4	
Rated speed	n_n	min ⁻¹	3250		2798		2050	
Connection resistance	R_{tt}	Ω	0.06		0.04		0.03	
Connection inductance	L_{tt}	mH	0.1		0.07		0.06	
Electrical time constant	τ_e	ms	1.81		1.96		2.24	
No. of pole pairs	p		10					
Mass moment of inertia	J	kgmm ²	270	400	540	800	1080	1600
Mass	m	kg	1.2	1.5	2.3	2.8	4.5	5.5
Char. curve	-	-	upon request		upon request		upon request	

Tbl - 9 Size 100 in voltage class B

Version	Size – Length - Voltage class		100-030-S		100-060-S		100-120-S	
	Inner diameter		E	A	E	A	E	A
Intermediate circuit voltage	U_{DC}	V	560					
Torque constant	k_m	Nm/A	1.88		1.88		1.89	
Voltage constant	k_e	Vs	1.54		1.54		1.54	
Motor constant	k_{mot}	Nm/ \sqrt{W}	0.55		0.87		1.32	
Ambient temperature	ϑ_u	°C	40					
Maximum winding temperature	ϑ_{max}	°C	155					
Heat transfer resistance	R_{th}	K/W	0.81		0.65		0.47	
Max. power	P_{max}	W	3421		6855		14919	
Maximum torque	M_{max}	Nm	16		32.5		64.2	
Maximum current	I_{max}	A	10		20		40	
Continuous stall torque	M_0	Nm	5.3		8.8		16.3	
Continuous stall current	I_0	A	2.8		5.2		8.8	
No-load speed	n_0	min ⁻¹	3467		3497		3460	
Rated power	P_n	W	1422		2662		3066	
Rated torque	M_n	Nm	4.3		7.7		10.7	
Rated current	I_n	A	2.4		3.9		6.1	
Rated speed	n_n	min ⁻¹	3150		3302		2750	
Connection resistance	R_{tt}	Ω	7.77		3.09		1.37	
Connection inductance	L_{tt}	mH	14.53		7.46		3.54	
Electrical time constant	τ_e	ms	1.87		2.42		2.58	
No. of pole pairs	p		10					
Mass moment of inertia	J	kgm ²	270	400	540	800	1080	1600
Mass	m	kg	1.2	1.5	2.3	2.8	4.5	5.5
Char. curve	-	-	upon request		upon request		upon request	

Tbl - 10 Size 100 in voltage class S

5.2.2 Size 112

Version	Size – Length		112-030		112-060		112-120	
	Inner diameter		E	A	E	A	E	A
Potting outer diameter B	A1	mm	109					
Potting outer diameter A	A2	mm	109					
Stator outer diameter	A3		112.5					
Stator length	B	mm	62		92		152	
Length of laminated core	B1	mm	30		60		120	
Height of winding head on A side	B2	mm	17					
Inner diameter of stator	C	mm	80					
Rotor inner diameter	D	mm	63	30	63	30	63	30
Rotor magnet length	E	mm	≤ 30		≤ 60		≤ 120	
Angle	F1	Degree	37					
Angle	F2	Degree	12.2					
Wire length	H	mm	300					
Power wire cross-section	-	mm ²	0.5 mm ²					
Power wire diameter (incl. sheath)	-	mm	2.53 mm ²					
Signal wire cross-section	-	mm ²	0.23 mm ²					
Signal wire diameter (incl. sheath)	-	mm	max. 1.3 mm					

Tbl - 11 Geometrical characteristics of size 112

Version	Size – Length - Voltage class		112-030-S		112-060-S		112-120-S	
	Inner diameter		E	A	E	A	E	A
Intermediate circuit voltage	U_{DC}	V	560					
Torque constant	k_m	Nm/A	1.84		2.15		2.69	
Voltage constant	k_e	Vs	1.5		1.76		2.2	
Motor constant	k_{mot}	Nm/ \sqrt{W}	0.72		1.14		1.73	
Ambient temperature	ϑ_u	°C	40					
Maximum winding temperature	ϑ_{max}	°C	155					
Heat transfer resistance	R_{th}	K/W	0.76		0.63		0.47	
Max. power	P_{max}	W	4771		7696		13264	
Maximum torque	M_{max}	Nm	22.6		45.5		90.4	
Maximum current	I_{max}	A	15		26		41	
Continuous stall torque	M_0	Nm	7.1		11.6		21.5	
Continuous stall current	I_0	A	3.9		6.0		8.1	
No-load speed	n_0	min ⁻¹	3554		3055		2434	
Rated power	P_n	W	1839		3086		3415	
Rated torque	M_n	Nm	5.3		10.2		14.2	
Rated current	I_n	A	3.1		4.6		5.6	
Rated speed	n_n	min ⁻¹	3300		2887		2300	
Connection resistance	R_{tt}	Ω	4.35		2.4		1.63	
Connection inductance	L_{tt}	mH	11.37		7.73		5.9	
Electrical time constant	τ_e	ms	2.62		3.22		3.63	
No. of pole pairs	p		10					
Mass moment of inertia	J	kgm ²	430	650	860	1300	1720	2600
Mass	m	kg	1.5	1.9	2.9	3.6	5.5	6.9
Char. curve	-	-	upon request		upon request		upon request	

Tbl - 12 Size 112 in voltage class S

5.3 Dimensional drawings

Specified dimensions and tolerances in the drawings are subject to the following standards:

- General tolerances: ISO 2768 mH
- Geometrical product specifications: ISO 14405

	<ul style="list-style-type: none"> • Use the corresponding internal documents (e.g. assembly instructions, circuit diagrams etc.) of your company.
---	---

① Detailed, current dimension sheets are available on request. The dimensions and tolerances listed here serve for orientation only.

5.4 Type code

The type code describes the motor variants and provides support for product selection and ordering from **WITTENSTEIN cyber motor**. The products of the cyber[®] kit line medium consist of the subassemblies "stator" and "rotor", which can be separately described as "CKLS..." (stator) and "CKLR..." (rotor) as well as in combination as "CKLC..." (stator and rotor).

Configuration	Column	Description
Product group	1-2-3	CKL is the designation of the product group of the cyber [®] kit line.
Product type	4	The product type defines the type of the product (stator, rotor, combination).
Size	5-6-7	The size is defined by the mechanical dimensions of the stator.
Length	10-11-12	The overall length is derived from the length of the active part.
Cooling type	13	"C" = natural convection
Voltage constant	15-16-17	The voltage constant serves to distinguish the winding variants and indicates the voltage constant in [Vs]. The following applies: <i>"x x x"</i> = voltage constant for values ≥ 10 <i>"x V x"</i> = voltage constant for values between 1.0 and 9.9 <i>"x K x"</i> = voltage constant in kVs ($\cdot 10^3$) <i>"x D x"</i> = voltage constant in dVs ($\cdot 10^{-1}$) <i>"x C x"</i> = voltage constant in cVs ($\cdot 10^{-2}$) <i>"x M x"</i> = voltage constant in mVs ($\cdot 10^{-3}$)
Voltage class	18	The voltage class is derived from the intermediate circuit voltage of the product.
Power connection	19	"A" = power cable with a length of approx. 300 mm "E" = power cable with a length of approx. 2000 mm
Feedback system	21-22	"NN" = without feedback system
Inner diameter	24	The inner diameter is defined by the mechanical dimensions of the rotor. "E" = large inner diameter "A" = small inner diameter
Temperature sensor	26	"V" – PT1000 and PTC (twisted)

Tbl - 13 Description of the type code

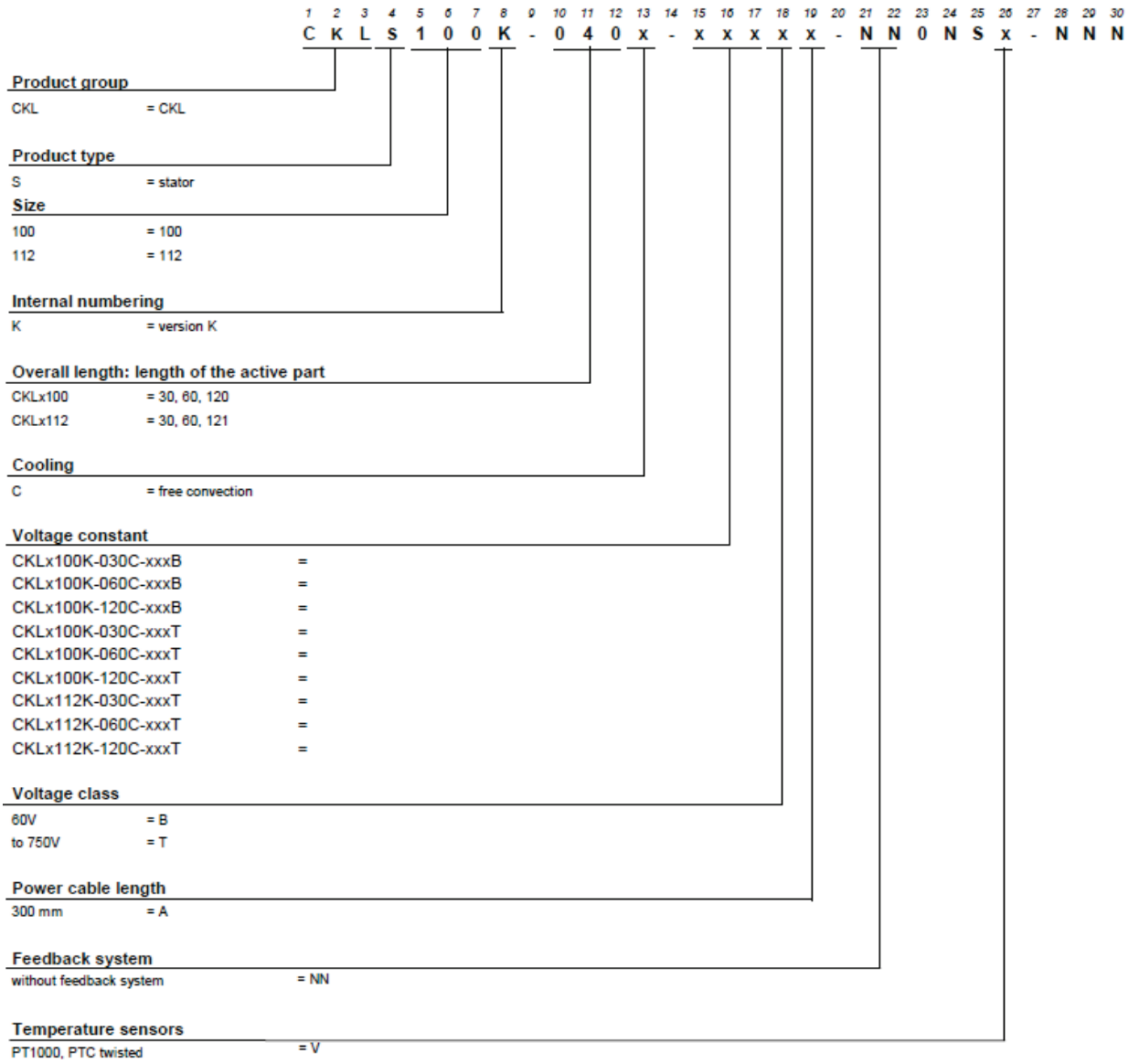

Fig. 5-3 Type code of the stators (CKLS) of the cyber® kit line medium

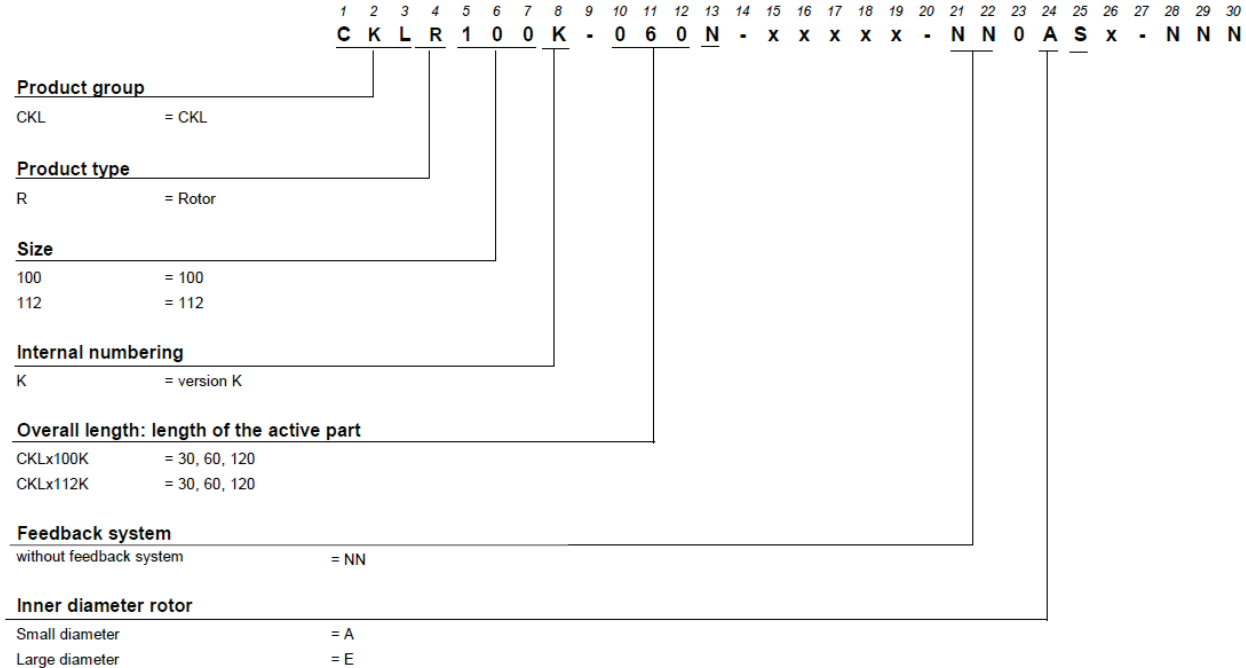

Fig. 5-4 Type code of the rotors (CKLR) of the cyber® kit line medium

The type code in the combined version (CKLC) consists of the type code of the stator (CKLS) and the rotor (CKLR) while the relevant digits are carried over. The necessary adjustments to the type code are highlighted in gray in the example illustrated in figure 5-5.

Column	1	2	3	4	5	6	7	8	9	10	11	12	13	14	15	16	17	18	19	20	21	22	23	24	25	26	27	28	29	30	31	32
Example „Combined“:	C	K	L	C	0	5	0	B	-	0	4	0	C	-	1	D	1	B	A	-	H	A	0	A	S	W	-	N	N	N		
Stator:	C	K	L	S	0	5	0	B	-	0	4	0	C	-	1	D	1	B	A	-	H	A	0	N	S	W	-	N	N	N		
Rotor:	C	K	L	R	0	5	0	B	-	0	4	0	N	-	N	N	N	N	N	-	H	A	0	A	S	N	-	N	N	N		

Fig. 5-5 Type code of the cyber® kit line medium in combined version (CKLC)

5.5 Installed components

5.5.1 Temperature sensor

The stators of the cyber® kit line medium include temperature sensors of type PT1000 and PTC in the twisted version. These must be connected to a suitable trigger unit or evaluation circuit of the power electronics to prevent the maximum winding temperature from being exceeded.

The temperature sensors of type PT1000 exhibit a linear characteristic curve with accuracy class 2B. The deviations of the PT1000 over the application range can be calculated as follows:

$$\Delta T = \pm(0.6^{\circ}C + 0.005 T)$$

The course of the PT1000 temperature sensor corresponds to the following figure:

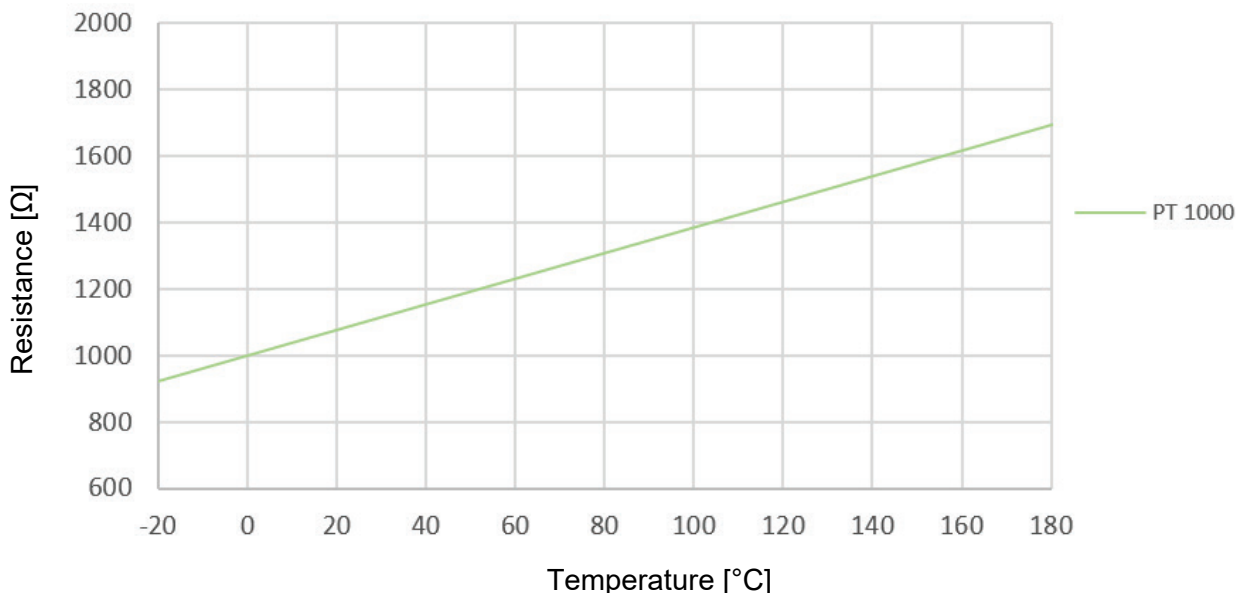

Fig. 5-6 Characteristic of the PT1000 resistance temperature chart

If the temperature sensor configuration "V" is selected in the type code, a resistance of $\geq 3000 \Omega$ at a temperature of $160 \text{ }^\circ\text{C}$ will set in (Fig 5-7).

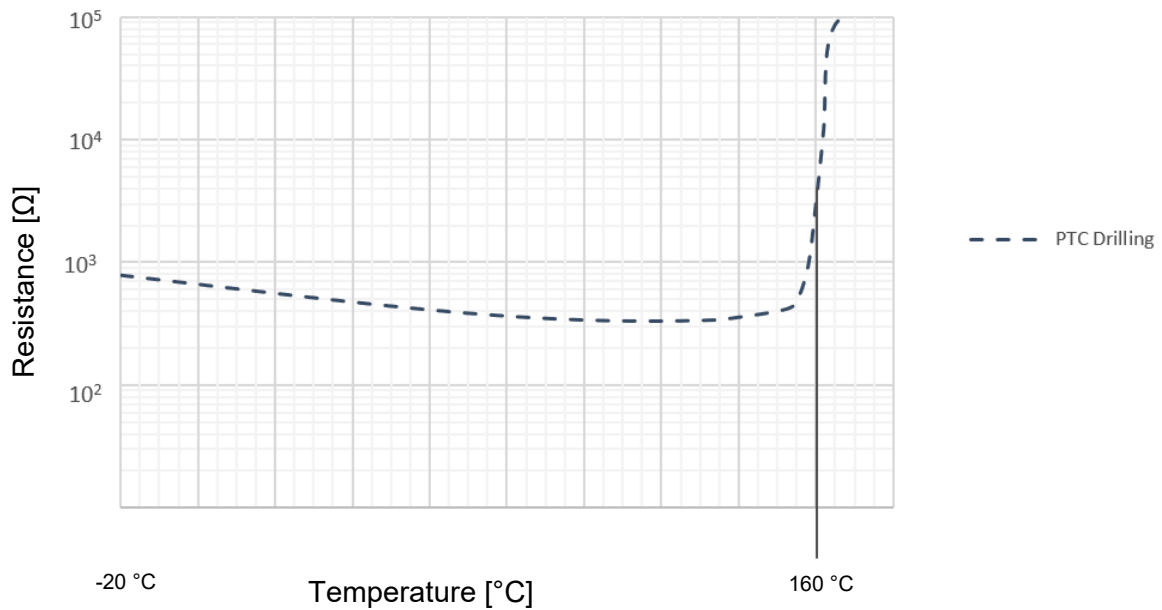





Fig. 5-7 Characteristic of the PTC twisted (type code "V"), PTC resistance temperature chart

	<p style="text-align: center;">NOTICE</p> <p>The products of the cyber[®] kit line medium are damaged if the maximum winding temperature is exceeded.</p> <ul style="list-style-type: none"> Select the motor with sufficient power and connect the temperature sensor to a suitable trigger unit or the drive electronics.
	<p style="text-align: center;">NOTICE</p> <p>Temperature sensors can be damaged due to electrostatic discharge.</p> <ul style="list-style-type: none"> Carry out the work in an ESD-protected work environment and with suitable personal protective equipment. Do not remove ESD safeguards from the connections before they are established.
	<p>The temperature sensors in the cyber[®] kit line medium models can be destroyed when subjected to high voltages.</p> <ul style="list-style-type: none"> The temperature sensors of sizes 100 and 112 are designed for "basic isolation" in accordance with EN 61800-5-1. To ensure motor protection, these installed temperature sensors must be monitored via the evaluation units. These evaluation units must ensure safe deactivation of the motor without any delay. The temperature sensors must be connected such that they ensure safe electrical isolation pursuant to the requirements for safety isolation in accordance with EN 61800-5-1, provided that this is necessary for safe operation.

5.5.2 Encoders

The products of the cyber[®] kit line medium are not equipped with an encoder.

5.5.3 Brake

The products of the cyber[®] kit line medium do not have a brake.

5.6 Accessories

For the products of the cyber[®] kit line medium, no accessories are available.

6 Assembly

6.1 General information

Type, scope and order of the assembly steps are influenced by the individual features of your machine design and can deviate from the schematic procedure.

	⚠ WARNING
	<p>Risk of injury due to live components and during lifting of heavy loads. Risk of damage to the product due to incorrect handling.</p> <ul style="list-style-type: none"> • Carefully carry out all steps. • Use suitable hoisting equipment and personal protective equipment. • Do not lift or move the product at the cables. • Do not install motors under voltage. • Observe the safety and handling instructions. • Before assembly, prepare instructions which fully describe all work and assembly steps. • Observe work and assembly instructions of your company.

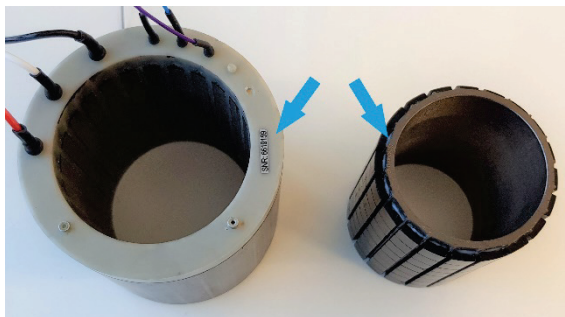

The products of the cyber® kit line medium are delivered with one or two enclosed name plates (see 4.1) as stickers. The name plate is clearly assigned to the product by the serial number on the respective product.

	<ul style="list-style-type: none"> • Attach the name plate at a visible location inside the machine to ensure easy assignment to the product. Observe any company-specific instructions.
---	---

Before assembly of the cyber® kit line medium, prepare the products by placing them on a clean and level surface. Check whether the products are damaged. Damaged components must not be assembled. Have the tools, auxiliaries, measuring and testing equipment ready and ensure that assembly is carried out in a clean, dry and dust-free environment. Make sure that there are no dirt and burrs at any components, assembly surfaces, bores and threads. Remove any burrs. Clean all components and assembly surfaces and remove any preservatives.

	<ul style="list-style-type: none"> • Observe cleanliness when carrying out all working steps.
---	--

6.2 Assembly of stators

6.2.1 Stators of size 100 and 112

The stator sizes 100 and 112 of the cyber® kit line medium are intended for installation into a housing surrounding the stator at its outer diameter. Select the dimensions of the housing in such a way that clearances and creepage distances in compliance with IEC 60664-1 at the side of the cable outlet (B side) are also complied with towards other surrounding components (dimension "S"). On the opposite side of the angle head (A side), additional clearances and creepage distances are not required as reliable separation of live components is ensured. An axial shoulder on the laminated core can be used as an alignment aid for the adhesion process.

	CKLS100		CKLS112	
Voltage class	B	T	B	T
Housing inner diameter D_G [mm]	100.0 ^{+0.15} / _{+0.12} (GX) (For adhesive bonding)		112.5 ^{+0.18} / _{+0.14} (GX) (For adhesive bonding)	
Fitting surface inner diameter D_A [mm]	min. 98.5		min. 110.4	
Axial distance to attached components [mm]	min. 0.5	min. 3.0		min. 3.0
Fitting surface F [mm]	min. 0.4		min. 0.6	
Housing material	Aluminum and steel materials			
Surface roughness R [mm]	Rz10		Rz16	

Tbl - 14 Overview of relevant parameters for the installation of the stators of sizes 100 and 112

A shoulder with the dimension "S" for compliance with required air and creepage distances pursuant to 60664-1 is to be provided for in the housing. This also applies for the axial distance to any attached components. The recommended inner diameter of the housing D_G recommended for adhesive bonding with a gap-filling adhesive is specified in figure6-1.

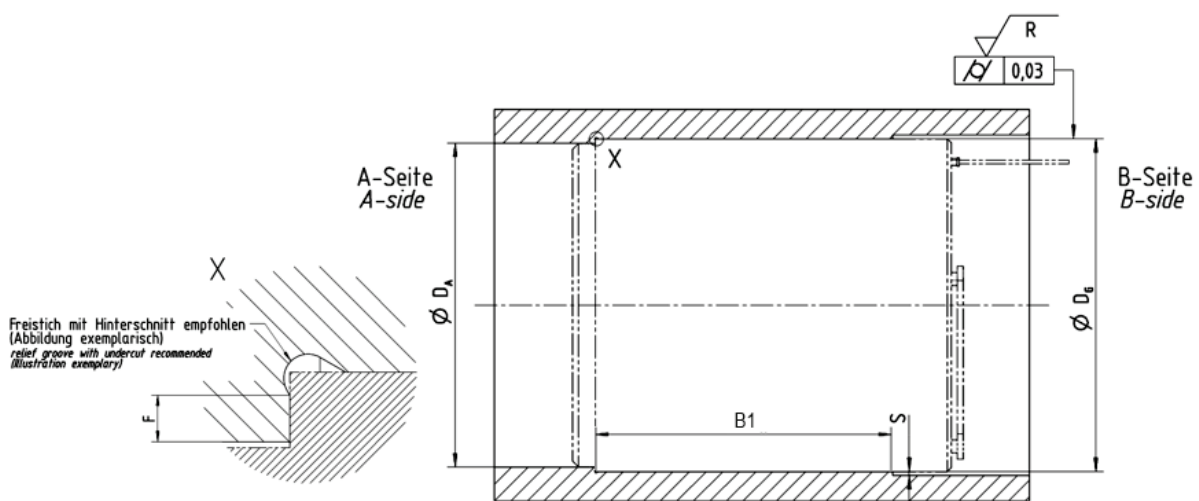



Fig. 6-1 Recommended housing dimensions for adhesive connections and clearances

For adhesive bonding of the stator sizes 100 and 112 of the cyber® kit line medium into a housing, proceed as follows:

- Have ready the stator, housing, adhesive and a suitable cleaning agent.

- Clean the surfaces of the parts to be bonded.
- Apply an adhesive activator to the housing to obtain a reactive surface.
- Apply adhesive on the surfaces to be bonded.
- Slide the stator into the housing.
- Keep the housing vertical in axis position until the adhesive has cured.

	<ul style="list-style-type: none">• Use gap-filling adhesive with a shearing strength of 15 N/mm² - 30 N/mm² (2200 PSI – 4400 PSI) under operating conditions (e.g. LOCTITE 648).
---	---

Alternatively, the stator of the sizes 100 and 112 can also be shrunk into an aluminum housing suitable for it. For this purpose, an adaptation of the housing inner diameter D_G is necessary. Please contact us for further information.

6.3 Assembly of rotors

The rotors are not prebalanced as an integration kit and must still be balanced as a group after assembly onto the shaft, as required.

The rotors of the cyber[®] kit line medium are fitted with permanent magnets. During all work at the rotors, observe the occurring radial and axial forces. These also occur if the rotors are inserted into the stator. For first approximation, calculate these forces:



$$F_{axial} = 0.33 \cdot Size^{1.2} [N]$$

$$F_{radial} = 0.0033 \cdot Size^{1.5} Length [N]$$

Respectively, the following forces apply during introduction of the rotor CKLR360B-100N-NNNNN-NN0ESN:

$$F_{axial} = 0.33 \cdot 360^{1.2} N = 386 N$$

$$F_{radial} = 0.0033 \cdot Size^{1.5} Length N = 0.0033 \cdot 360^{1.5} \cdot 100 N = 2254 N$$

	<p style="text-align: center;">⚠ WARNING</p> <p>Components equipped with permanent magnets and components that emit magnetic fields can influence/impede the function of active medical implants (e.g. pacemakers, defibrillators). This can lead to serious injuries or even death.</p> <ul style="list-style-type: none"> • Assembly and storage areas must not be accessed by personnel with active body implants, which may be affected by permanent magnetic fields. • Include the warning into the assembly instructions of your company. • Make sure that the warning remains at the product as long as a hazard exists.
	<p style="text-align: center;">⚠ CAUTION</p> <p>During the mechanical assembly of kit motors, the attraction forces of the magnets can cause serious crushing injuries and damage to the motor or the application.</p> <ul style="list-style-type: none"> • Avoid unwanted movement of components of the kit motors by suitable auxiliaries for assembly. • Have all mechanical assembly and maintenance work carried out by qualified personnel only. • Only use suitable non-magnetic tools for assembly and maintenance work.
	<p style="text-align: center;">NOTICE</p> <p>Incorrect assembly of kit motors can lead to damage at products.</p> <ul style="list-style-type: none"> • Use suitable assembly accessories to ensure that the rotor does not get into contact with the stator when it is inserted.

6.3.1 Rotors of size 100 and 112

The rotor of the cyber[®] kit line medium is intended for assembly at a shaft holding the rotor at the inner diameter. The rotor can be introduced into the stator from both sides. The dimensions of the shaft D_W recommended for adhesive bonding with a gap-filling adhesive is specified in figure 6-2. The parameters for the assembly of the rotor can be found in the following table:

	CKLR100		CKLR112	
Inner diameter	E	A	E	A
Shaft outer diameter D_W [mm]	50.0 f8 (GN)	24.0 f8 (GN)	63.0 f8 (GN)	30.0 f8 (GN)
Fitting surface diameter D_A [mm]	Max. \varnothing 68	open towards the top	Max. \varnothing	open towards the top
Shaft material	Steel materials			
Surface roughness R [mm]	Rz16	Rz10	Rz16	Rz10

Tbl - 15 Overview of relevant parameters for the installation of the rotors of sizes 100 and 112

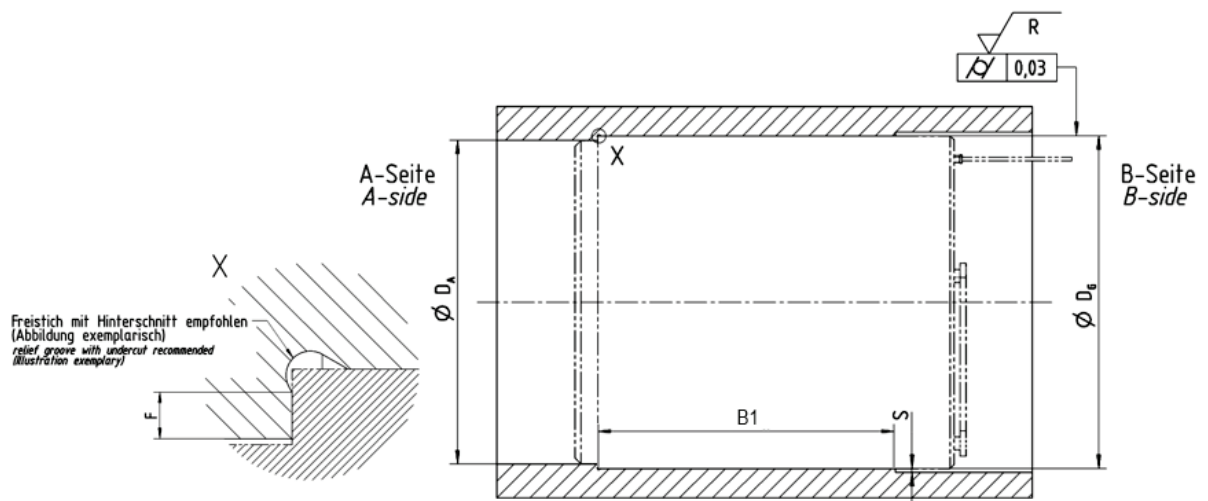

Fig. 6-2 Recommended shaft dimensions for adhesive connections

For adhesive bonding of the rotor of the cyber[®] kit line medium onto a shaft, the following procedure is recommended:

- Have ready the rotor, shaft, adhesive and a suitable cleaning agent.
- Clean the surfaces of the parts to be bonded.
- Apply adhesive on the surfaces to be bonded.
- Slide the rotor on the shaft to its position flush against a shaft shoulder. As far as possible, this should not exhibit any axial misalignment to the shoulder in the housing and/or to the laminated stator core. An axial misalignment between the laminated stator core and the magnet bearer can lead to losses in output and axial constraining forces on bearings.
- Remove any excessive adhesive.
- Keep the shaft horizontal in axis direction until the adhesive has cured.

i	<ul style="list-style-type: none"> Use gap-filling adhesive with a shearing strength of 15 N/mm² - 30 N/mm² (2200 PSI – 4400 PSI) under operating conditions (e.g. LOCTITE 648).
i	<ul style="list-style-type: none"> Provide an undercut for shafts with shaft shoulder.

6.4 Assembly of rotor/stator in the application

When entering the rotor into the stator, no collision must occur, as this can result in the destruction of the permanent magnets. A collision or contact is to be prevented using corresponding insertion devices and/or protective measures.

In the assembly, the internal surface of the laminated stator core and the external surface of the rotor (permanent magnets) should face each other concentrically as far as possible and without axial displacement. Here, a max. axial displacement of the fitting surfaces of 0.1 mm and a max. concentricity of 0.1 mm is recommended. This is to be ensured through corresponding specifications in the housing and on the shaft. Considerably greater axial displacement leads to axial forces on the bearing. Depending on the balance weights, considerably greater concentricity can lead to collisions between the rotor and the stator and to the destruction of the permanent magnets.

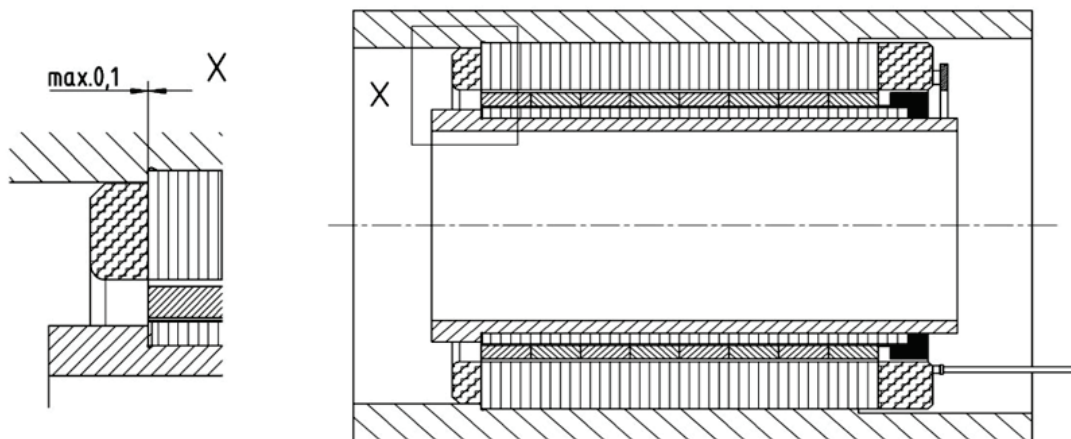



Fig. 6-3 Sketch of the assembly of the rotor and the stator in the application

6.5 Electrical connection

The products of the cyber® kit line medium are intended for connection to a suitable drive control unit with variable output voltage and frequency.

	⚠ CAUTION
	<p>Risk of injury (electric shock) and destruction of the products at direct power supply connection.</p> <ul style="list-style-type: none"> • Always connect the products to a suitable drive control unit.

- Establish the electrical connection according to the connection diagrams.

	<ul style="list-style-type: none"> • Ensure correct fitting of connectors and cables for strain relief.
---	--

The electrical connection of the stators is established with a connection cable via a terminal box or connector. Make sure that the current rating of the connection elements and the connection cable is sufficient for the type of installation. Observe the connection schematics in chapter 7.

	<p>The electrical connection of the stators is not suitable for drag chains.</p> <ul style="list-style-type: none"> • In drag chains, only use suitable cables.
--	---

7 Connection technology

7.1 General information

	<ul style="list-style-type: none"> • Use the corresponding internal documents (e.g. assembly instructions, circuit diagrams etc.) of your company.
---	---

- For preparation and execution of the connections, always observe the applicable standards and any local requirements.
- Check the electromagnetic compatibility (EMC).
- Prepare a risk assessment of the residual risks.
- Carry out any additionally required measures.

7.2 Safety instructions

	⚠ DANGER
	<p>Faulty electrical connections or unapproved, current-carrying components can cause serious injuries and even death.</p> <ul style="list-style-type: none"> • Ensure that electrical connections are only established by qualified personnel. • Observe valid standards and directives. • Carry out connection work only with suitable tools. • Immediately replace damaged cords or plugs.

	⚠ DANGER
	<p>Electrically live parts may result in electric shocks if touched and can cause serious injuries and even death. Electrical work performed in damp areas may result in electric shocks and can cause serious injuries and even death.</p> <ul style="list-style-type: none"> • Ensure that electrical connections are only established by qualified personnel. • Observe valid standards and directives. • Carry out connection work only with suitable tools. • Observe the general installation and safety regulations for work at electrical systems. • Before accessing electrical parts with voltages exceeding 50V, disconnect the product from the voltage supply. Secure the product against reactivation. • Do not make contact with electrical connections of the product while it is activated under any circumstances.

	⚠ WARNING
	<p>Connecting or disconnecting the power and signal supply lines <i>under voltage</i> can lead to machine damage, serious injury or even death.</p> <ul style="list-style-type: none"> • Make sure that the product and the connections of the electronics (power and signal) are in a voltage-free state before connecting. • Observe any discharge time of your components.

	NOTICE
	<p>If present, the temperature sensors and rotor position encoders, particularly Hall effect sensors and encoders, can be damaged by electrostatic discharge.</p> <ul style="list-style-type: none"> • Carry out the work in an ESD-protected work environment and with suitable personal protective equipment. • Do not remove ESD safeguards from the connections before they are established.

7.3 Connection schematics

The color coding of the cables or wires of connection cables does not depend on the selected stator model. Observe the relevant sections on "Cable connection" and "Feedback system" of the type code. A feedback system is currently not available for the cyber® kit line medium. Accordingly, the type code includes the following marking:

Power connection	A
Feedback system	NN
Illustration in	Fig. 7-1

Tbl - 16 Connection marking according to the type code

The motor phases for connection to the three-phase power connection of the control unit are marked with "MOT/PH/U", "MOT/PH/V" and "MOT/PH/W". Make sure that the motor phases are correctly assigned to ensure that the direction of rotation of the motor complies with standards. Motors with power connection "A" are intended for installation in a housing (see chapter 6.2). Depending on the intermediate circuit voltage, the electrical protection concept and the layout of your machine, a PE conductor may need to be connected to the housing in which the motors are installed. Take into account local legal requirements and applicable standards.

	⚠ CAUTION
	<p>Risk of injury (electric shock) in the case of insufficient PE conductor.</p> <ul style="list-style-type: none"> • Observe local requirements and applicable standards for connection of a PE conductor and the Hall sensors. • Check whether the components require connection of PE conductors. • Connect the available and required PE conductors. • Route the wires of the Hall sensors separately from the power wires.

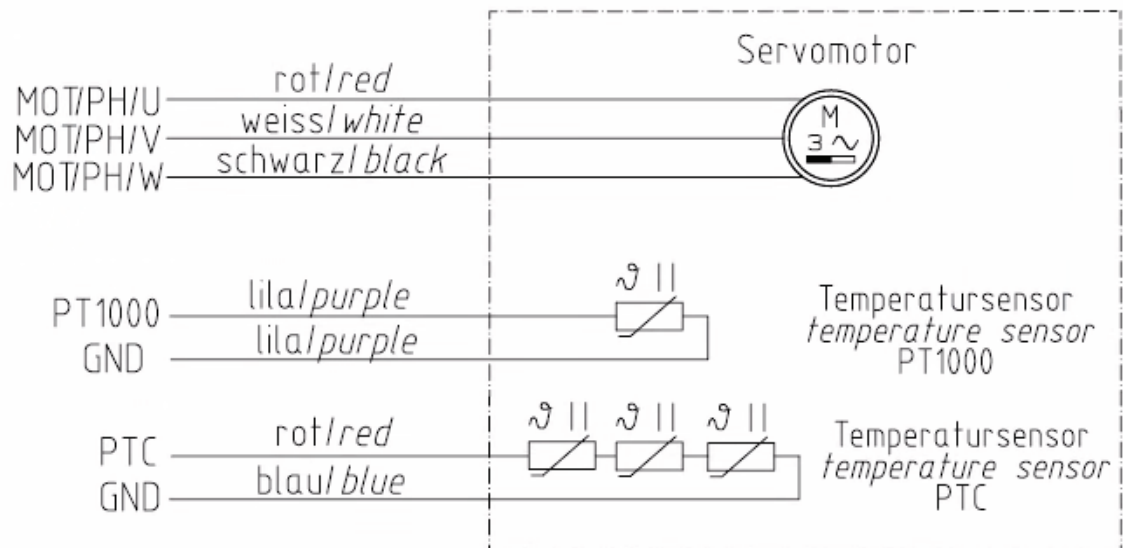



Fig. 7-1 Connection marking for power connection "A" and feedback system "NN"

The temperature sensors (see chapter 5.5.1) serve for monitoring and protection of the stator against damage due to overtemperature. Connect at least one temperature sensor suitable for the application to the evaluation circuit or the trigger unit of the power electronics. The products of the cyber® kit line medium contain two temperature sensors in order to offer a wide-ranging connectivity and sufficient evaluation possibilities.

	<h2 style="margin: 0;">NOTICE</h2>
	<p>Risk of damage due to motor overheating.</p> <ul style="list-style-type: none"> Parameterize the temperature sensor in your control unit. Select the correct characteristic curve according to the manufacturer specifications for the control unit. Parameterize the correct warning and trigger temperatures according to the manufacturer specifications for the control unit and your requirements as machine manufacturer.

Before connection of the motors with power connection "A", the following work must be carried out by the machine manufacturer:

- Determine the type of connection (terminal box or connector) and obtain the required components. Make sure that the components for currents and voltages and the required protection class are suitable.
- If necessary, shorten the power connection to the required length.
- Firmly connect the power connection to the selected connection and check secure fitting of the wire or the cable.
- Secure the connection and the line connection at the machine.

	NOTICE
	<p>Kinking and continuous motion of the line connection can lead to broken cables and other irreparable damage.</p> <ul style="list-style-type: none">• Observe the minimum bending radius of the line connection: Sizes 100 and 112: 5.0 x diameter of the power connection at fixed installation 10.0 x diameter of the power connection at flexible installation• Secure the line connection at the machine.



For dimensioning and installation of electrical connections, particularly observe the following points:

- Make sure that the required line cross-sections also comply with applicable local requirements and the selected installation type.
- Carefully install the screen connections in compliance with EMC guidelines.
- Carefully install screw-fittings and plug connections for compliance with the protection class.
- Do not open or loosen any on-site cable fittings at the stator.
- Make sure that the coolant, lubricant and operating media used in the machine do not damage the line connections or cause any chemical or structural alterations.

8 Startup and operation

8.1 General instructions for commissioning

The instructions for commissioning refer to the motor as part of a drive system with at least one control unit.

	<h3>⚠ WARNING</h3>
	<p>Errors during control of motors and moving elements can lead to machine damage as well as serious injury or even death.</p> <ul style="list-style-type: none"> • Do not commission the product if connections, operating states or product data are missing or unclear. • Do not commission the product if safeguards and monitoring equipment at the system are damaged or defective. • Make sure that the product is suitable for the intended application. • Observe the technical cleanliness. • Ensure that only properly qualified and professionally trained personnel who are able to assess the safe condition of the product work at the product.
	<ul style="list-style-type: none"> • Use the corresponding internal documents (e.g. assembly instructions, circuit diagrams etc.) of your company.

Before commissioning, the following steps must typically be carried out:

- Keep ready the documentation of all used products.
- Protocol all work carried out.
- Check the products and machine for damage.
- Check all mechanical and electrical connections.
- When setting up and programming the machine, observe the assignments of the directions of rotation of the motor and the encoder.
- Activate the safeguards and monitoring systems of the machine.

Commissioning of control units and controllers can require further steps. Checking the functionality and performance of the machine is not part of these project specifications and must be carried out by the machine manufacturer in the course of overall commissioning of the machine. Observe the specifications and instructions of the machine manufacturer.

8.2 Safety instructions

	<h3>⚠ WARNING</h3>
	<p>When the shaft is still turning or when the product is driven externally (generator operation), voltage is induced. This can cause lethal current surges.</p> <ul style="list-style-type: none"> • Ensure that connections and connectors are not open and unprotected against contact. • Do not make contact with electrical connections of the product while it is activated under any circumstances.

	⚠ WARNING
	<p>Moving components on the product can pull in or crush parts of the body or eject objects and cause serious injuries and even death. A wrong direction of rotation or direction of movement may result in serious injury or death.</p> <ul style="list-style-type: none"> • Remove objects and tools from the motor before putting it into operation. • Make sure that all components at the product are secured according to the assembly instructions of your company. • Keep a sufficient distance to moving machine components when the motor is running. • Secure the machine against restarting and unintentional movement during assembly and maintenance work. • Before and during startup, ensure that the motor has the correct direction of rotation. • Avoid collisions (e.g. moving against an end stop). • Check the direction of rotation in a slow motion, ideally by limiting the current and torque in a secured danger area.

	⚠ NOTICE
	<p>Some control units of different manufacturers use proprietary data specifications. If the data convention is not observed, the motor and/or the control unit may be damaged.</p> <ul style="list-style-type: none"> • Observe the listed units precisely and check their conformance with the units of the control unit. • The technical data of WITTENSTEIN cyber motor are specified in SI units according to IEC 80000 and coherent units. Have the manufacturer provide you with the regulations on conversion of SI units to the notation of the control unit.

The products of the cyber® kit line medium are kit motors with individual components to be installed into the machine by the machine manufacturer. Kit motors do not feature a data memory for provision of motor parameters and/or parameters of the control unit. All parameters must be entered manually during commissioning or loaded into the control unit.

- ① Take into account that these parameters also apply for the direction of rotation of the encoder and the commutation offset.

8.3 Preconditions and auxiliaries

For successful commissioning, the following preconditions must be complied with:

- Compliance with safety instructions and information.
- Checking of all electrical and mechanical components for safe function
- Availability of all required auxiliaries
- Availability of a suitable control unit

	NOTICE
	<p>The control units of different manufacturers may lead to early failure of the insulation system.</p> <ul style="list-style-type: none"> • Select a suitable control unit for the intermediate circuit voltage U_{DC} of the motor. • Make sure that the voltage gradient of the pulsed voltage at the control unit does not exceed a limit value of 8 kV/μs at the cable connections of the motor. • Parameterize the control unit in such a way that the admissible maximum current I_{max} is not exceeded. • If applicable, use thermal protective equipment.

	NOTICE
	<p>The performance of the control units of different manufacturers may not be sufficient.</p> <ul style="list-style-type: none"> • Select a suitable control unit for the speed of the application. Observe the required output frequency of the control unit. • Make sure that the control unit provides the maximum current required in the application for the required duration.

The converter performance data required for an intended operation can be found in the characteristic curve.

The output frequency of the control unit and/or the necessary rotary field frequency f_U can be calculated with the pole pair number p and the speed n_M of the motor.

$$f_U = p * n_M$$

	<p>The motors of the cyber[®] kit line medium are multi-pole ($p > 10$). Therefore, high output frequencies on the converter are required for corresponding speeds.</p> <p>With the sizes BG100 and BG112 ($p = 10$), rotary field frequencies of 600 Hz are already reached at 3600 rpm.</p>
	<ul style="list-style-type: none"> • Ensure that the selected control unit exhibits corresponding output frequencies.

Commissioning is performed with the commissioning software of your drive control unit or controller. If a cyber[®] simco[®] drive 2 control unit is used, the MotionGUI 2 software is recommended. It requires a standard PC with Windows operating system. For commissioning via your controller by means of a control terminal, access to all drive parameters and functions must be ensured.



For drive optimization, an oscilloscope is required. The MotionGUI 2 software features an integrated oscilloscope function for graphical illustration of signals.

For troubleshooting and checking of components, a multimeter may be useful for current, voltage and resistance measurement.

8.4 General procedure for commissioning

The general procedure for commissioning requires the following steps. If control units of other manufacturers are used and for the specific installation situation of the machine, other and additional steps may be required. Firstly, observe the specifications and instructions of the machine manufacturer and any applicable local standards and regulations:

- Make sure that all connections, functions and safeguards are functional without faults.
- In case of initial commissioning, load the default settings of the control unit ("default values").
- Parameterize the control unit with the specific motor parameters. For this, use the technical data in these project specifications (chapter 5) and take into account any necessary conversions and the units in the control unit.
- Parameterize any position encoders and/or other feedback systems.
- Parameterize the drive limits like maximum positions, maximum velocities, maximum acceleration, maximum stroke, etc.
- Parameterize any necessary application-specific parameters.
- Determine the encoder polarity. If the direction of rotation of the drive deviates from the direction of rotation of the encoder, invert the parameter for the direction of rotation of the encoder of your control unit. To do so, please refer to the instructions for your control unit. Carry out this step until the direction of rotation of the drive complies with the direction of rotation of the encoder.
- Determine the optimum commutation setting and store it in the control unit. Refer to the instructions for your control unit.
- Carry out the settings and optimize the control circuits. Refer to the instructions for your control unit.

	<h2 style="margin: 0;">⚠ WARNING</h2>
	<p>Moving components on the product can pull in or crush parts of the body or eject objects and cause serious injuries and even death. A wrong direction of rotation or direction of movement may result in serious injury or death.</p> <ul style="list-style-type: none"> • Remove objects and tools from the motor before putting it into operation. • Make sure that all components at the product are secured according to the assembly instructions of your company. • Keep a sufficient distance to moving machine components when the motor is running. • Secure the machine against restarting and unintentional movement during assembly and maintenance work. • Avoid collisions (e.g. moving against an end stop). • Check the direction of rotation in a slow motion, ideally by limiting the current and torque in a secured danger area. • If the encoder system is replaced, repeat all necessary steps for commissioning.
	<ul style="list-style-type: none"> • Thoroughly carry out all steps for commissioning. Optimum parameterization enables maximum efficiency of the product and supports the correct function of your machinery.

9 Maintenance

Within their service life and the specified ambient and operating conditions, the products of the cyber® kit line medium do not require any maintenance. Regular preventative maintenance according to the machine maintenance plan of the machine manufacturer increases the reliability of the machine. **WITTENSTEIN cyber motor** recommends carrying out the following maintenance:

- Checking of mechanical and electrical connections according to the machine maintenance plan and at least every 1000 operating hours or every 3 months.
- Checking of flexible cables and lines according to the machine maintenance plan and at least every 500 operating hours or monthly.
- Checking of the machine for smooth operation, vibration and noise according to the machine maintenance plan and at least every 1000 operating hours or every 3 months.
- Checking of the function and cleanliness of the cooling system according to the machine maintenance plan and at least every 1000 operating hours or every 3 months.
- Removal of dust, chipping and other dirt from motor housings, cooling ribs and other connections depending on the degree of pollution, however, at least every 8000 operating hours or 12 months.

	⚠ CAUTION
	<p>Risk of serious crushing injury due to incorrect handling during maintenance.</p> <ul style="list-style-type: none"> • During maintenance, secure the machine against restarting and unintended movement. • Have all mechanical maintenance carried out by qualified personnel only. • For maintenance, only use suitable tools.

	⚠ CAUTION
	<p>Hot surfaces can cause serious injuries.</p> <ul style="list-style-type: none"> • Let the products cool down for a sufficient period after switching them off and before maintenance. • When working with hot surfaces, always wear protective gloves.

9.1 Cleaning

Cleaning of the machine according to specifications of the machine manufacturer increases the reliability of the machine. The products of the cyber® kit line medium are kit motors installed into the machine according to the specifications of the machine manufacturer. **WITTENSTEIN cyber motor** recommends the following basic approach for cleaning of products:

- Remove dust, chipping and other dirt from the product.
- If necessary, use suitable non-aggressive cleaning agents.
- Check compatibility before cleaning.

	⚠ CAUTION
	<p>Risk of serious crushing injury due to incorrect cleaning during maintenance.</p> <ul style="list-style-type: none"> • During cleaning, secure the machine against restarting and unintended movement. • For cleaning, only use suitable tools.

	⚠ CAUTION
	<p>Hot surfaces can cause serious injuries.</p> <ul style="list-style-type: none"> • Let the products cool down for a sufficient period after switching them off and before cleaning. • When working with hot surfaces, always wear protective gloves.

9.2 Visual inspection

During maintenance, carry out a visual inspection according to specifications of the machine manufacturer and record all irregularities in the machine maintenance plan. **WITTENSTEIN cyber motor** recommends the following basic approach for visual inspection:

- Visually inspect all mechanical and electrical connections.
- Check cables and lines for visible damage.
- Check mechanical components for damage and wear.
- Check the machine for leakage and dirt.

	Regular visual inspection and definition of measures help to prevent malfunctions and unscheduled downtimes.
---	--

9.3 Disassembly

	⚠ WARNING
	<p>Components equipped with permanent magnets and components that emit magnetic fields can influence/impede the function of active medical implants (e.g. pacemakers, defibrillators). This can lead to serious injuries or even death.</p> <ul style="list-style-type: none"> • Assembly and storage areas must not be accessed by personnel with active body implants, which may be affected by permanent magnetic fields. • Include the warning into the assembly instructions of your company. • Make sure that the warning remains at the product as long as a hazard exists.

	⚠ CAUTION
	<p>During mechanical disassembly, handling errors can lead to serious crushing injuries as well as to damage to the product or the application.</p> <ul style="list-style-type: none"> • During disassembly, secure the machine against restarting and unintended movement. • Have all mechanical disassembly carried out by qualified personnel only. • For disassembly, only use suitable tools.

	⚠ CAUTION
	<p>During the mechanical disassembly of kit motors, the attraction forces of the magnets can cause serious crushing injuries and damage to the motor or the application.</p> <ul style="list-style-type: none"> • Avoid unwanted movement of components of the kit motors by suitable auxiliaries for assembly. • Have all mechanical disassembly carried out by qualified personnel only. • For disassembly, only use suitable non-magnetic tools.

	⚠ CAUTION
	<p>Hot surfaces at the product (e.g. housing, motor housing) can cause serious injuries.</p> <ul style="list-style-type: none"> • Let the product cool down for a sufficient period after switching it off. • When working with hot surfaces, always wear protective gloves.

Before disassembly of the products of the cyber® kit line medium, shut down the machine. For shut down, observe the instructions in the machine documentation. **WITTENSTEIN cyber motor** recommends the following general approach:

- Switch off all line and control voltages including the main switch of the machine.
- Secure the machine against unintended movements, restarting and unauthorized operation.
- Wait for all electrical systems to fully discharge and disconnect any electrical connections if necessary.
- Before disassembly and loosening of mechanical connections, secure all components against falling or movements.
- Drain any coolant channels before opening.
- Disassemble the axis or motor from the machine and store the motor or motor components according to instructions.
- Please note that, for example, disassembly of glued connections may not be possible and connected components may need to be disassembled as a whole.
- Protocol all work carried out in the machine maintenance plan.

9.4 Disposal

For free-of-charge disposal, the products of the cyber® kit line medium can be returned to **WITTENSTEIN cyber motor** after removal of any residues of oil, grease or adhesives and other dirt. Additionally, the products must not contain any inadmissible foreign substances or components.

Please send the products for disposal postage paid to the following address:

WITTENSTEIN cyber motor GmbH

Customer Service

Walter-Wittenstein-Straße 1

97999 Igersheim, Germany

Packaging materials include wood, cardboard, plastic enclosure, VCI paper, VCI pad, foam, ESD foam pad, ESD bags, desiccant bags and/or adhesive tape. Dispose of the packaging materials at the recycling sites intended for this purpose and observe applicable national regulations. For ecological reasons, the packaging materials should not be returned.

The products of the cyber® kit line medium have a high metal content and are therefore suitable for recycling. To achieve optimum recycling of metals and materials, disassembly into individual subassemblies is required. **WITTENSTEIN cyber motor** recommends separation of glued parts for recycling of materials. After separation, plastics must be forwarded to thermal processing.

10 Service & support

WITTENSTEIN cyber motor offers service and support services.

If you have technical questions, please contact the following address:

Consulting and sales	
Phone	+49 (0) 7931 493 15800
Email	info@wittenstein-cyber-motor.de
Address	WITTENSTEIN cyber motor GmbH Sales department Walter-Wittenstein-Straße 1 D-97999 Igersheim

Tbl - 17 Contact data: WITTENSTEIN cyber[®] motor Sales

In case of any technical malfunctions, please contact the following address:

Customer Service	
Phone	+49 (0) 7931 493 15900
Email	service@wittenstein-cyber-motor.de
Address	WITTENSTEIN cyber motor GmbH Customer Service Walter-Wittenstein-Straße 1 D-97999 Igersheim

Tbl - 18 Contact data: WITTENSTEIN cyber[®] motor Customer Service

If you have any questions about installation, startup or optimization, please contact our support hotline:

Support hotline	
Phone	+49 (0) 7931 493 14800
Email	wcm-support@wittenstein.de

Tbl - 19 Contact data: WITTENSTEIN cyber[®] motor support hotline

- Please have the following information ready:
 - Detailed description of the malfunction and the circumstances
 - Type code and serial number of respective products
 - Phone number and email address for contact

	<ul style="list-style-type: none"> • Observe the assembly instructions of your company regarding possible malfunctions and information on troubleshooting.
---	---

Revision history

Revision	Date	Comment	Chapter
01	5/21/2024	New version	All



cyber motor

WITTENSTEIN cyber motor GmbH · Walter-Wittenstein-Straße 1 · 97999 Igersheim · Germany

Tel. +49 7931 493-15800 · info@wittenstein-cyber-motor.de

WITTENSTEIN Inc. · 1249 Humbracht Circle · Bartlett, IL 60103 · USA

Tel. +1 630 540 5300 · info@wittenstein-us.com

WITTENSTEIN S.P.A. · Via Giosuè Carducci 125 · 20099 Sesto San Giovanni MI · Italy

Tel. +39 02 241357-1 · info@wittenstein.it

WITTENSTEIN (Hangzhou) Co., Ltd. · No. 355 Tianmushan West Road · 311122 Hangzhou · Zhejiang · China

Tel. +86 571 8869 5852 / 5851 · info@wittenstein.cn

WITTENSTEIN Ltd. · 2-6-6 Shibadaimon · Minato-ku · Tokyo 105-0012 · Japan

Tel. +81 3 6680 2835 · sales@wittenstein.jp

WITTENSTEIN – one with the future

www.wittenstein-cyber-motor.de