

WITTENSTEIN



motion control



TPM(A) 010 – 110

**BOSCH REXROTH
(Indramat)
ECODRIVE 03**

Quick Startup Guide

Version : 1.2
Date : 19th October 2005
File : 4091_D006343_3.doc
Doc.No. : 4091-D006343-03

Technical changes reserved!

Table of Contents

TABLE OF CONTENTS.....	2
1 GENERAL INFORMATION AND SAFETY INSTRUCTIONS	3
2 NAME PLATE DATA DETAILS.....	4
3 PARAMETERIZATION.....	5
3.1 3 RD PARTY MOTOR FILE	5
3.1.1 <i>Selecting the motor parameter file during initial start-up drive</i>	5
3.2 PARAMETER INPUT VIA SINGLE PARAMETER.....	6
3.2.1 <i>Starting the dialog single parameter input.....</i>	6
3.2.2 <i>Parameter input</i>	6
4 PARAMETERS TPM 025 - 110 600V AT ECODRIVE 03 DKC**.040.....	7
5 PARAMETERS TPM 010 600V AT ECODRIVE 03 DKC**.016.....	8
6 PARAMETERS TPMA 025 - 110 600V AT ECODRIVE 03 DKC**.040	9
7 CONNECTION SCHEMATIC TPM / TPMA ↔ ECODRIVE 03	10
7.1 TPM / TPMA WITH RESOLVER FEEDBACK	10
7.2 TPM / TPMA WITH ABSOLUTE ROTARY ENCODER ECN 1313 / EQN 1325.....	10
8 DIAGNOSTIC MESSAGES DURING INITIAL START-UP	11
9 ASSIGNMENT TPM ↔ SERVO AMPLIFIER ↔ CABLE SET	12
9.1 TPM WITH RESOLVER FEEDBACK	12
9.2 TPM WITH ABSOLUTE ENCODER ECN 1313 / EQN 1325.....	13

Modification History

Document Designation	Version	Date	Note
4091_D006343_1.doc	1.0	15.05.2003	First edition
4091_D006343_2.doc	1.1	19 th March 2004	Correction wiring schemes and cable cross reference table. TPMA added.
4091_D006343_3.doc	1.2	19 th October 2005	Correction parameter S-0-0106 and S-0-0107 for TPM010-110

Contact address:

WITTENSTEIN motion control GmbH

Walter-Wittenstein-Strasse 1
97 999 Igersheim

Tel. : 07931 / 493-0
Fax : 07931 / 493-200
Email : info@w-m-c.de

1 General Information and Safety Instructions

This guide serves as an aid during start-up and inspection of TPM motor gear units with servo amplifiers. It contains the following points:

- Start-Up information
- Parameter lists for the TPM series
- Connection schematic for TPM
- Assignment table TPM – Servo amplifier - cable set

Please be sure to carefully read through this document before starting up the TPM and also be sure to read the documentation provided by the manufacturer of the servo amplifier.



WITTENSTEIN motion control will not be held liable for the consequences of the improper, negligent, or incorrect installation or setting of the servo amplifier's operating parameters.

All of the installation, operation, and safety information provided in the servo amplifier documentation is to be observed.

Observe all of the national safety regulations and guidelines of the country where the device is being used. All transportation, installation, start-up, and service work is to be performed by qualified technicians. Qualified technicians are those who are completely familiar with the assembly, installation, and operating procedures, as well as all warnings and safety measures in accordance with the country-specific regulations. Furthermore, they are trained, instructed, and authorised to set the electrical circuits and other devices into operation in accordance with safety regulations.

The drives are intended to be installed in machines being used in commercial applications. You may only operate the equipment if you comply to the national EMC regulations (refer to the servo amplifier documentation for installation information pertaining to EMC) as they are defined for the given application.

Note: All of the product brand names which appear in this Quick Start Guide are trademarks of the relevant companies. If the ® and/or ™ symbols are omitted, this does not imply that the name is a free brand name.

2 Name plate data details

The following specifications can be found on the identification plate. Please select the input parameters corresponding to the nameplate values of your drive.

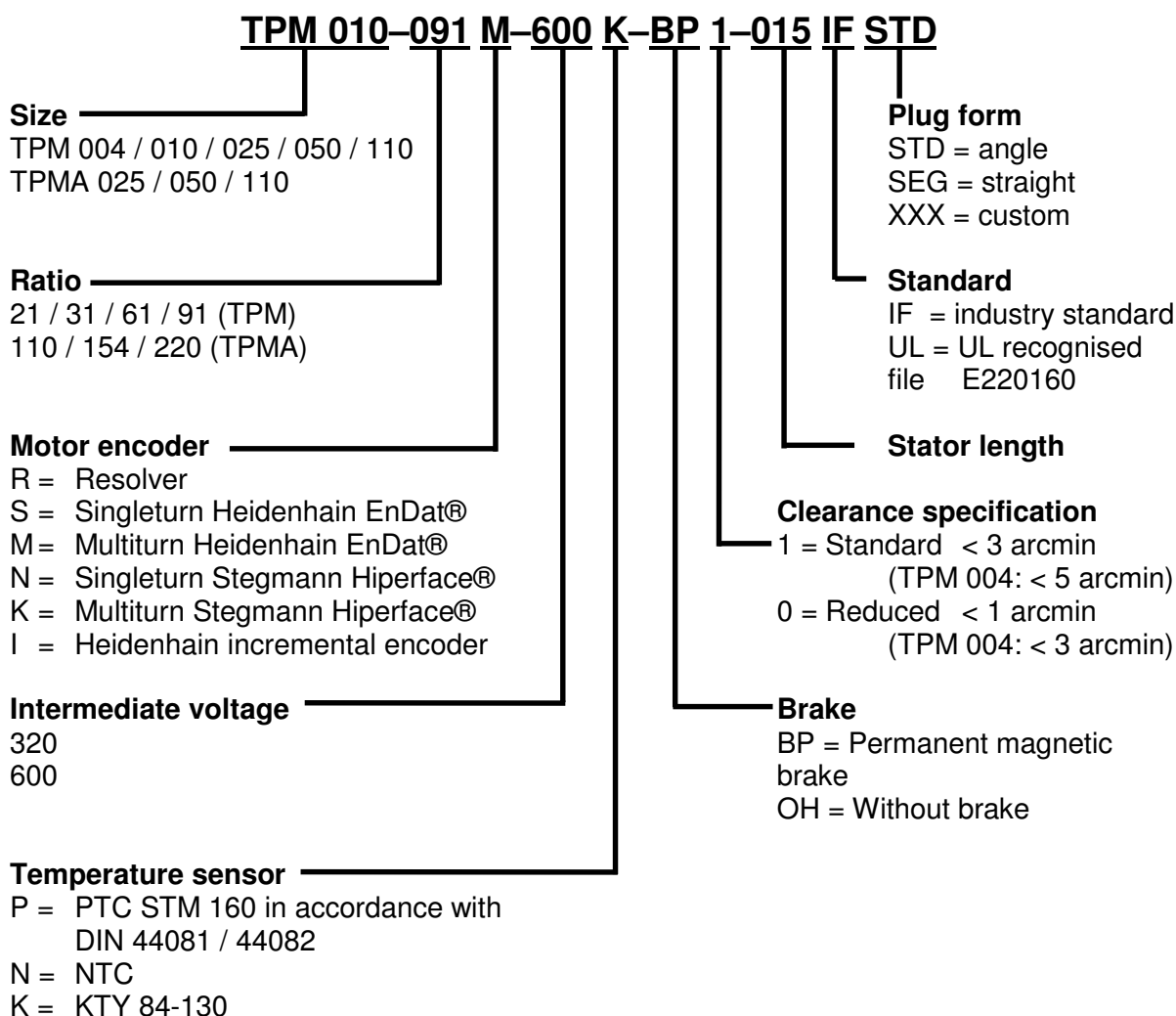

3 Parameterization

To operate the TPM together with a drive of the EcoDrive03-family the motor parameters need to be put in.

The tables in section 4 resp. 5 contain all of the parameters that are required for the initial start-up of a TPM motor-gear unit from WITTENSTEIN motion control together with a Bosch Rexroth EcoDrive. When the TPM and the servo amplifier are properly connected, these parameters guarantee that the TPM can be operated without load in speed control. Based on these default settings, the dynamics of the speed loop can be optimized depending on the application.

Together with the Drivetop-Software the data can either be loaded as a 3rd party motor file or can be input via single parameter dialog.

3.1 3rd party motor file

With this option the motor parameters are loaded as predefined 3rd party motor parameter file. You can download matching parameter files for your TPM at www.w-m-c.de.

3.1.1 Selecting the motor parameter file during initial start-up drive

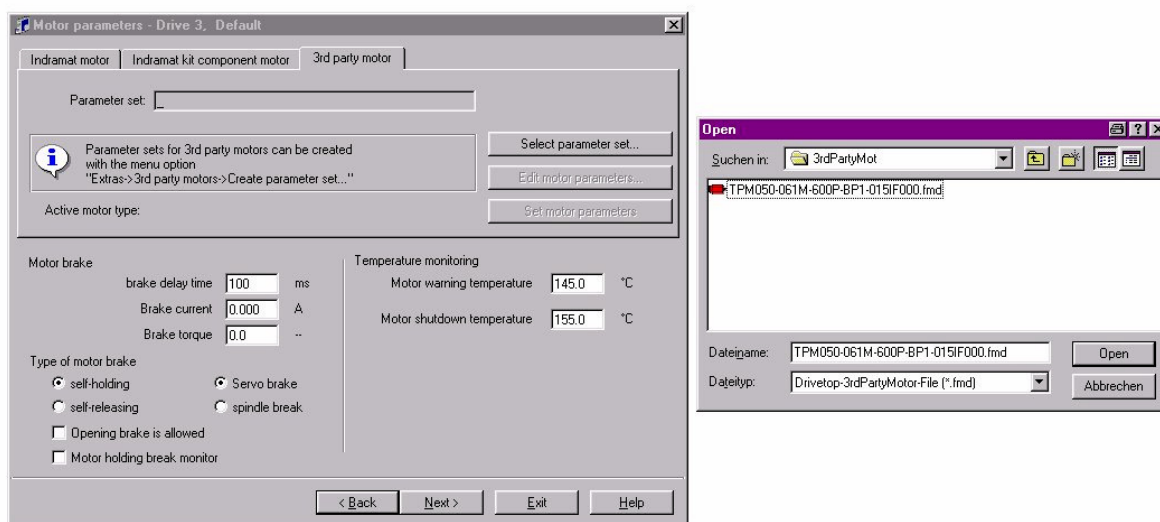

- Select the file corresponding to your TPM.
- Set the motor parameters.
- Configure the application to your requirements.
- During initial start-up parameter S-0-0091 will be set to 100 rpm. Depending on the selected scaling (reference to motor or load) the value needs to be changed to achieve maximum speed.

3.2 Parameter input via single parameter

With this option each parameter number and each parameter value needs to be put in. In this case it is necessary to use the parameters from table in section 4 or 5 depending on the TPM you use.

3.2.1 Starting the dialog single parameter input

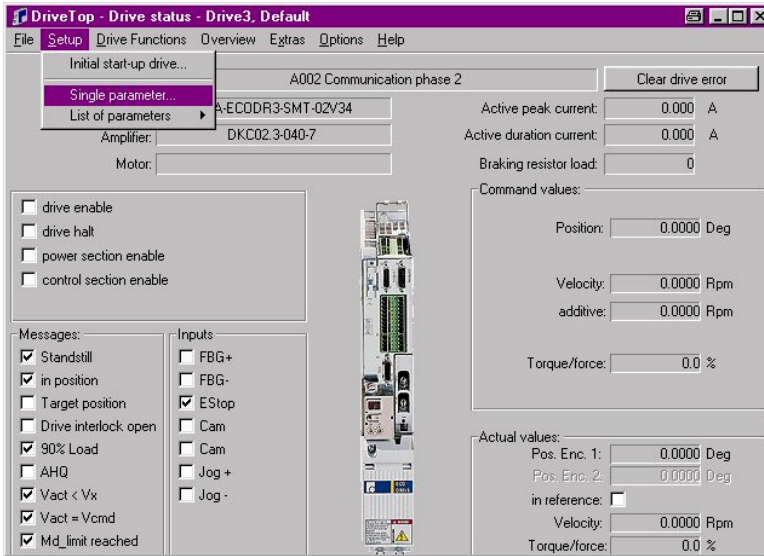

3.2.2 Parameter input

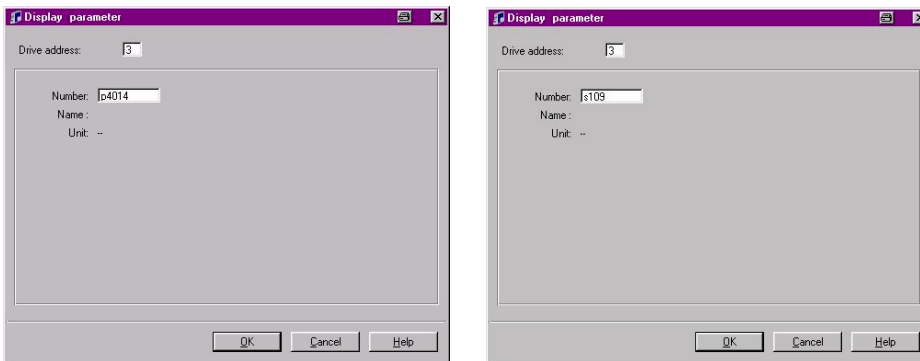

Input of p4014 is sufficient for selecting Parameter P-0-4014, s109 for S-0-0109.

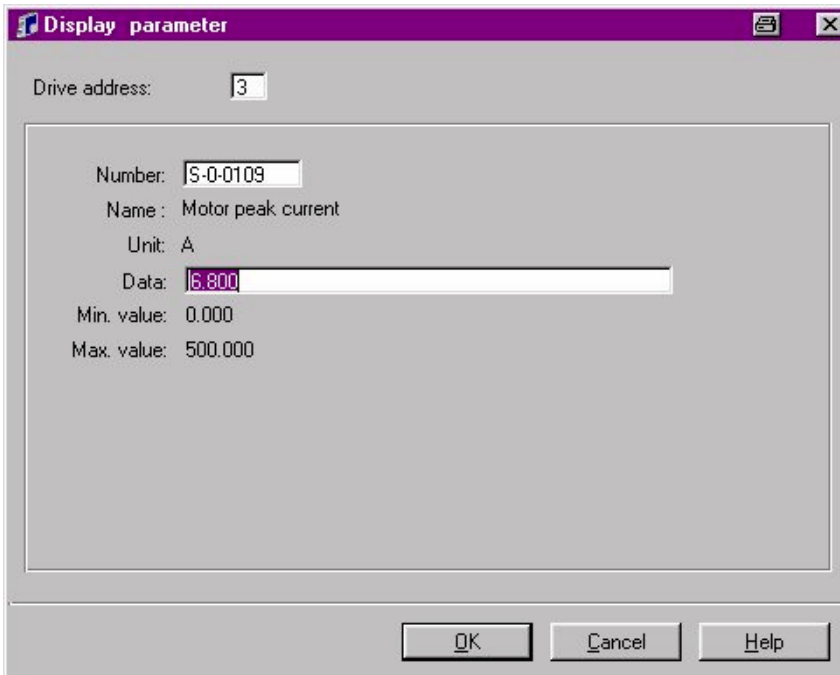

Put in the appropriate values.

4 Parameters TPM 025 - 110 600V at EcoDrive 03 DKC**.040

Data for combinations not shown here are available on demand.

Code	Description	TPM025	TPM050	TPM110
P-0-4014	Motor type	7	7	7
P-0-4011	Switching frequency [kHz]	8	8	8
P-0-0018	Number of pole pairs	6	6	6
P-0-0508	Commutation offset Resolver	510	510	510
P-0-0508	Commutation offset EnDat ¹	510 ¹	510 ¹	510 ¹
S-0-0092	Bipolar torque / force limit value [%]	500	500	500
P-0-0109	Torque / Force limit value. [%]	500	500	500
S-0-0201	Motor warning temperature [°C]	130	130	130
S-0-0204	Motor shutdown temperature [°C]	145	145	145
S-0-0113	Maximum motor speed [rpm] Resolver	6000	5000	4300
	Maximum motor speed [rpm] EnDat	5850	5000	4300
S-0-0100	Velocity loop control gain [As/rad]	0.2	0.2	0.2
S-0-0101	Velocity loop integral action time [ms]	10	10	10
P-0-0004	Velocity loop smoothing time constant [µs]	500	500	500
P-0-0074	Feedback 1 type			
	Resolver / EnDat		10 / 8	
S-0-0043	Velocity polarity parameter			
	Resolver / EnDat		0111 / 0000	
S-0-0055	Position polarities			
	Resolver / EnDat		1111 / 0000	
S-0-0085	Torque / Force polarity parameter			
	Resolver / EnDat		0111 / 0000	
S-0-0116	Feedback 1 resolution Resolver		1	
S-0-0116	Feedback 1 resolution EnDat		2048	
Ratio 21 / 31				
Stator length		045	060	075
S-0-0109	Motor peak current [A _{peak}]			
	Ratio i=21	15.000	59.10	37.000
	Ratio i=31	15.000	51.50	37.000
S-0-0111	Motor current at standstill [A _{peak}]	6.200	21.600	17.100
S-0-0106	Current loop proportional gain 1 [V/A]	18.000	4.10	8.3
S-0-0107	Current loop integral action time 1 [ms]	1.30	1.40	2.60
P-0-4047	Motor inductance [mH]	10.000	2.400	5.400
P-0-4048	Stator resistance [Ohm]	3.800	0.360	0.720
P-0-0051	Torque / Force constant [Nm/A _{peak}]	0.870	0.640	1.070
P-0-0511	Brake current [A]	0.500	1.100	1.100
P-0-0525	Type of motor brake	00	00	00
P-0-0526	Brake control delay [ms]	6	10	10
P-0-0540	Brake Torque / Force [Nm]	1.8	15	15
Ratio 61 / 91				
Stator length		015	015	060
S-0-0109	Motor peak current [A _{peak}]			
	Ratio i=61	9.900	19.400	52.50
	Ratio i=91	6.700	13.800	33.80
S-0-0111	Motor current at standstill [A _{peak}]	3.300	5.100	21.600
S-0-0106	Current loop proportional gain 1 [V/A]	20.00	16.00	4.10
S-0-0107	Current loop integral action time 1 [ms]	0.70	1.50	1.40
P-0-4047	Motor inductance [mH]	12.500	12.500	2.400
P-0-4048	Stator resistance [Ohm]	9.200	4.500	0.360
P-0-0051	Torque / Force constant [Nm/A _{peak}]	0.540	0.720	0.640
P-0-0511	Brake current [A]	0.500	0.600	1.100
P-0-0525	Type of motor brake	00	00	00
P-0-0526	Brake control delay [ms]	6	7	10
P-0-0540	Brake Torque / Force [Nm]	1.8	4	15

¹ It may be necessary to put in this parameter with the help from the commutation angle detection routine from the DriveTop Software.

5 Parameters TPM 010 600V at EcoDrive 03 DKC**.016

The DKC**.016 supports only motors with resolver.

Data for combinations not shown here are available on demand.

Code	Description	TPM010
P-0-4014	Motor type	7
P-0-4011	Switching frequency [kHz]	8
P-0-0018	Number of pole pairs	4
P-0-0508	Commutation offset Resolver	510
S-0-0092	Bipolar torque / force limit value [%]	500
P-0-0109	Torque / Force limit value. [%]	500
S-0-0201	Motor warning temperature [°C]	130
S-0-0204	Motor shutdown temperature [°C]	145
S-0-0113	Maximum motor speed [rpm] Resolver	7000
S-0-0100	Velocity loop control gain [As/rad]	0.010
S-0-0101	Velocity loop integral action time [ms]	10
P-0-0004	Velocity loop smoothing time constant [μs]	500
P-0-0074	Feedback 1 type	
	Resolver	10
S-0-0043	Velocity polarity parameter	
	Resolver	0111
S-0-0055	Position polarities	
	Resolver	1111
S-0-0085	Torque / Force polarity parameter	
	Resolver	0111
S-0-0116	Feedback 1 resolution Resolver	1
Ratio 21 / 31		
Stator length		030
S-0-0109	Motor peak current [Apeak]	
	Ratio i=21	7.100
	Ratio i=31	7.100
S-0-0111	Motor current at standstill [Apeak]	1.800
S-0-0106	Current loop proportional gain 1 [V/A]	35
S-0-0107	Current loop integral action time 1 [ms]	0.8
P-0-4047	Motor inductance [mH]	20.300
P-0-4048	Stator resistance [Ohm]	19.300
P-0-0051	Torque / Force constant [Nm/Apeak]	0.590
P-0-0511	Brake current [A]	0.500
P-0-0525	Type of motor brake	00
P-0-0526	Brake control delay [ms]	6
P-0-0540	Brake Torque / Force [Nm]	1.8
Ratio 61 / 91		
Stator length		015
S-0-0109	Motor peak current [Apeak]	
	Ratio i=61	3.500
	Ratio i=91	2.200
S-0-0111	Motor current at standstill [Apeak]	1.100
S-0-0106	Current loop proportional gain 1 [V/A]	50.00
S-0-0107	Current loop integral action time 1 [ms]	0.60
P-0-4047	Motor inductance [mH]	30.500
P-0-4048	Stator resistance [Ohm]	44.200
P-0-0051	Torque / Force constant [Nm/Apeak]	0.550
P-0-0511	Brake current [A]	0.500
P-0-0525	Type of motor brake	00
P-0-0526	Brake control delay [ms]	6
P-0-0540	Brake Torque / Force [Nm]	1.8

6 Parameters TPMA 025 - 110 600V at EcoDrive 03 DKC**.040

Data for combinations not shown here are available on demand.

Code	Description	TPMA025	TPMA050	TPMA110
P-0-4014	Motor type	7	7	7
P-0-4011	Switching frequency [kHz]	8	8	8
P-0-0018	Number of pole pairs	6	6	6
P-0-0508	Commutation offset Resolver	510	510	510
P-0-0508	Commutation offset EnDat ²	510 ²	510 ²	510 ²
S-0-0092	Bipolar torque / force limit value [%]	500	500	500
P-0-0109	Torque / Force limit value. [%]	500	500	500
S-0-0201	Motor warning temperature [°C]	130	130	130
S-0-0204	Motor shutdown temperature [°C]	145	145	145
S-0-0113	Maximum motor speed [rpm] Resolver	6000	5000	4500
	Maximum motor speed [rpm] EnDat	5850	5000	4500
S-0-0100	Velocity loop control gain [As/rad]	0.200	0.200	0.200
S-0-0101	Velocity loop integral action time [ms]	10	10	10
P-0-0004	Velocity loop smoothing time constant [μs]	500	500	500
P-0-0074	Feedback 1 type			
	Resolver / EnDat		10 / 8	
S-0-0043	Velocity polarity parameter			
	Resolver / EnDat		0111 / 0000	
S-0-0055	Position polarities			
	Resolver / EnDat		1111 / 0000	
S-0-0085	Torque / Force polarity parameter			
	Resolver / EnDat		0111 / 0000	
S-0-0116	Feedback 1 resolution Resolver		1	
S-0-0116	Feedback 1 resolution EnDat		2048	
ratio 110 / 154 / 220				
stator length		015	015	060
S-0-0109	Motor peak current [A _{peak}]			
	Ratio i=110	9.900	19.400	58.500
	Ratio i=154	7.700	15.900	40.700
	Ratio i=220	5.200	10.000	27.200
S-0-0111	Motor current at standstill [A _{peak}]	3.300	5.100	21.600
S-0-0106	Current loop proportional gain 1 [V/A]	20	16.00	4.10
S-0-0107	Current loop integral action time 1 [ms]	0.70	1.50	1.40
P-0-4047	Motor inductance [mH]	12.500	12.500	2.400
P-0-4048	Stator resistance [Ohm]	9.200	4.500	0.360
P-0-0051	Torque / Force constant [Nm/A _{peak}]	0.540	0.720	0.640
P-0-0511	Brake current [A]	0.500	0.600	1.100
P-0-0525	Type of motor brake	00	00	00
P-0-0526	Brake control delay [ms]	6	7	10
P-0-0540	Brake Torque / Force [Nm]	1.8	4	15

² It may be necessary to put in this parameter with the help from the commutation angle detection routine from the DriveTop Software.

7 Connection schematic TPM / TPMA ↔ EcoDrive 03

For detailed information about cable design and screening the documentaion of the drive manufactur-er has to be consulted.

7.1 TPM / TPMA with resolver feedback

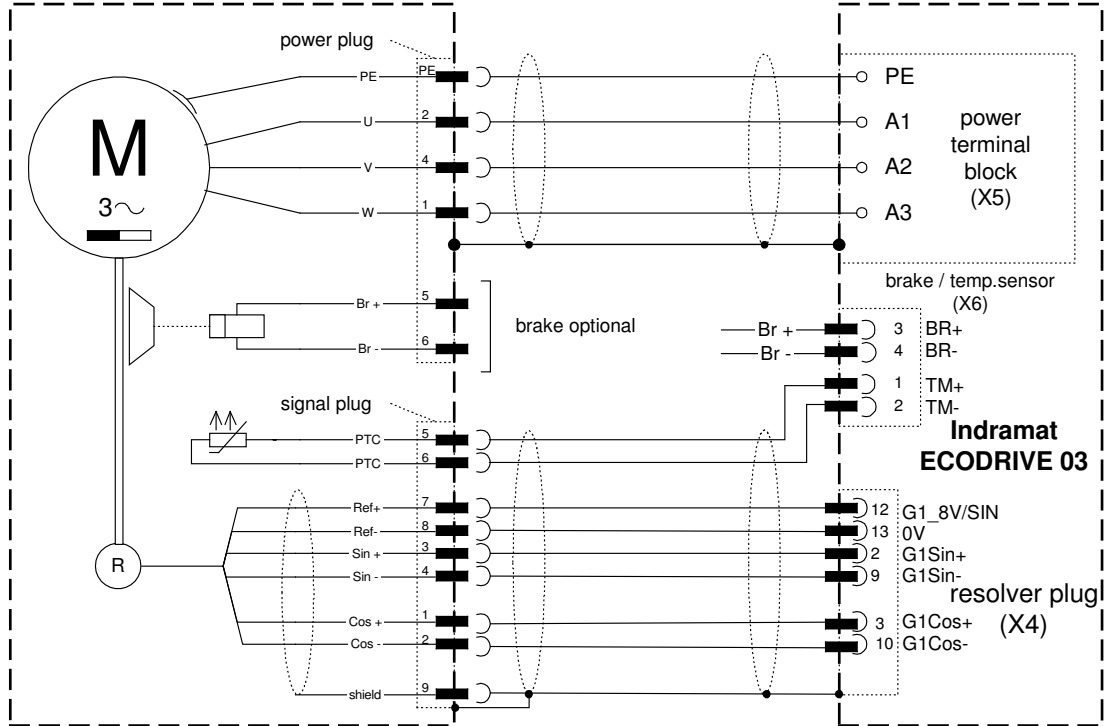

7.2 TPM / TPMA with absolute rotary encoder ECN 1313 / EQN 1325

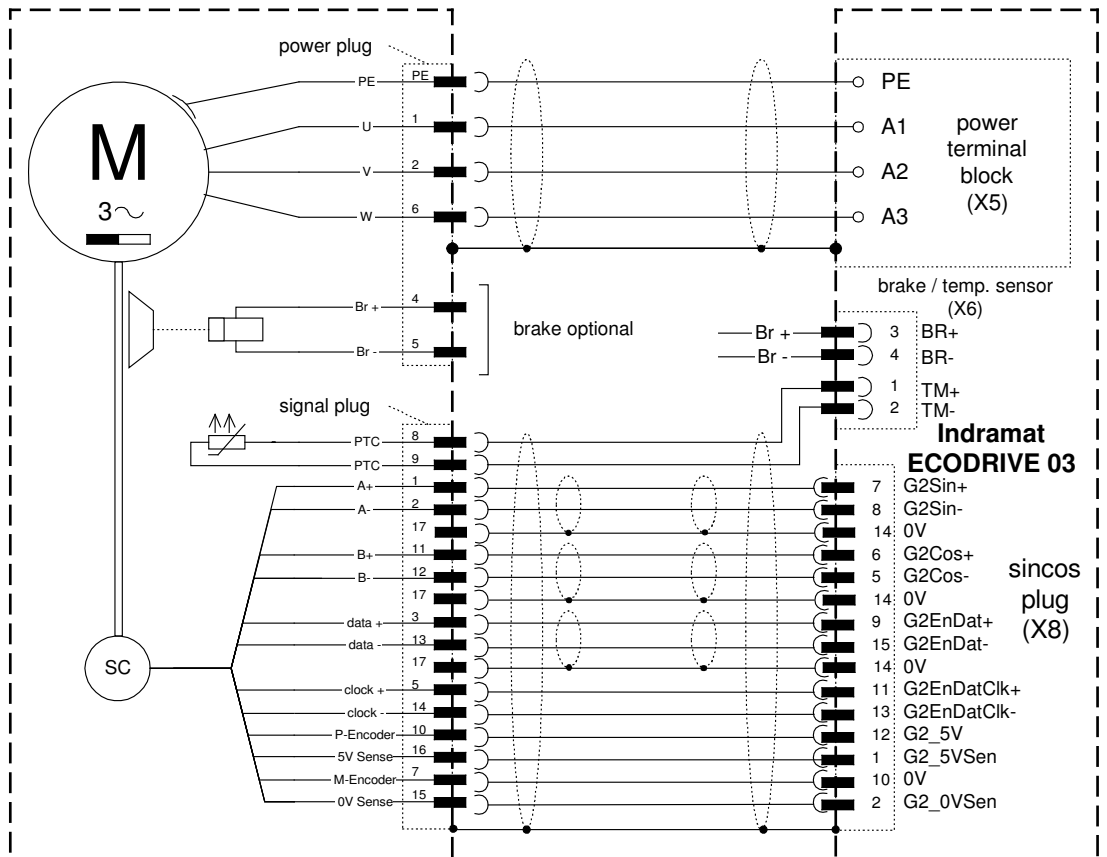

8 Diagnostic messages during initial start-up

During initial start-up faults may occur. Following diagnostic messages could appear with an correctly working TPM. For further investigations please consult the documentation from Bosch Rexroth.

Diagnostic message	Possible cause	Solution
F228 Excessive deviation F878 Velocity loop error F879 Velocity limit S-0-0091 exceeded	Commutation angle not correct	Check wiring of motor and motor feedback. Verify that P-0-0508 was taken over correctly by the drive. If not please activate the commutation angle determination routine.
F276 Absolute encoder out of window	Initial start-up	Set absolute measurement
F230 Max. signal frequency of encoder 1 exceeded	Cutoff frequency of EnDat feedback interface is limited to 200kHz. When using the 2048 lines this results in a maximum speed of 5859 rpm.	Check speed loop setting. If necessary check wiring of motor and commutation offset angle.
E263 Velocity command value > limit S-0-0091	Speed command exceeds the value for bipolar limit in S-0-091.	Adjust the value for S-0-0091 according your application. Verify the scaling of your application.

9 Assignment TPM / TPMA ⇔ servo amplifier ⇔ cable set

9.1 TPM / TPMA with resolver feedback

Feed-back	TPM type		Controller		article code for power (L) and feedback (S) cables																					
	size	i	recommendation WMC ¹		5m		10m		15m		20m		25m		30m		40m		50m							
			320V	600V	L	S	L	S	L	S	L	S	L	S	L	S	L	S	L	S						
Resolver																										
	TPM 010	021	-	DKC 0x.3-016-7		4000 3876	4000 6132	4000 3877	4000 3878	4000 3879	4000 6169	4000 6093	4000 7678	4000 7452	4000 6133	4000 6142	4000 6134	4000 6143	4000 6135	4000 7592	4000 7668	4000 7669	4000 7682	4000 7669	4000 7683	4000 7670
		031	-	DKC 0x.3-016-7																						
		061	-	DKC 0x.3-016-7																						
		091	-	DKC 0x.3-016-7																						
	TPM(A) 025	021, 031, 061, 091	-	DKC 0x.3-040-7		4000 6140	4000 6132	4000 6141	4000 6142	4000 6134	4000 6143	4000 6135	4000 7591	4000 7668	4000 6133	4000 6142	4000 6134	4000 6143	4000 6135	4000 7592	4000 7668	4000 7669	4000 7682	4000 7669	4000 7683	4000 7670
		110, 154, 220	-	DKC 0x.3-040-7																						
	TPM(A) 050	061, 091	-	DKC 0x.3-040-7		4000 8089	4000 6132	4000 8090	4000 6142	4000 6134	4000 6143	4000 6135	4000 7591	4000 7668	4000 6133	4000 8091	4000 6134	4000 6143	4000 6135	4000 7592	4000 7668	4000 7669	4000 7682	4000 7669	4000 7683	4000 7670
		110, 154, 220	-	DKC 0x.3-040-7																						
	TPM(A) 110	021, 031	-	DKC 0x.3-100-7		4000 8089	4000 6132	4000 8090	4000 6142	4000 6134	4000 6143	4000 6135	4000 7591	4000 7668	4000 6133	4000 8091	4000 6134	4000 6143	4000 6135	4000 7592	4000 7668	4000 7669	4000 7682	4000 7669	4000 7683	4000 7670
		021, 031, 061, 091	-	DKC 0x.3-040-7																						
		110, 154, 220	-	DKC 0x.3-040-7		4000 8089	4000 6132	4000 8090	4000 6142	4000 6134	4000 6143	4000 6135	4000 7591	4000 7668	4000 6133	4000 8091	4000 6134	4000 6143	4000 6135	4000 7592	4000 7668	4000 7669	4000 7682	4000 7669	4000 7683	4000 7670

¹ WMC recommendation is based on use of a power stage with maximal PWM-frequency. Please refer to WMC or controller manufacture to select optimized controller size for the application. Possibly you are able to use a smaller controller.

Power and Feedback cables for TPM with Resolver

all cable complete and for dynamic laying

power cable TPM 004-050

KABELL-TPM_ -xxINDE-RES015-STG

structure power cable: 4 x 1,5mm² + 2 x (2 x 1mm²), diameter 12,2mm, min. bending radius 122mm

power cable TPM 110

KABELL-TPM_ -xxINDE-RES025-STG

structure power cable: 4 x 2,5mm² + 2 x (2 x 1mm²), diameter 15,1mm, min. bending radius 151mm

feedback cable

KABELS-TPM_ -xxIND_ -RES000-STG

structure feedback cable: 3 x (2 x 0,14mm²) + 4 x 0,14mm² + 4 x 0,25mm² + 2 x 0,5mm²
diameter 10mm; min. bending radius 100mm

(xx = cable length)

9.2 TPM / TPMA with absolute encoder ECN 1313 / EQN 1325

Feed-back	TPM type		Controller				article code for power (L) and feedback (S) cables													
	size	i	recommendation WMC ¹		5m		10m		15m		20m		25m		30m		40m		50m	
			320V	600V	L	S	L	S	L	S	L	S	L	S	L	S	L	S	L	S
Absolute Single-/Multiturn feedback with EnDat interface	TPM(A) 025	021, 031, 061, 091	-	DKC 0x.3-040-7	4000 6144	4000 6136	4000 6145	4000 6137	4000 6146	4000 6138	4000 6147	4000 6139	4000 7684	4000 7652	4000 7685	4000 7653	4000 7686	4000 7654	4000 7687	4000 7655
		110, 154, 220	-	DKC 0x.3-040-7																
		061, 091	-	DKC 0x.3-040-7																
		110, 154, 220	-	DKC 0x.3-040-7																
		021, 031	-	DKC 0x.3-100-7																
		021, 031, 061, 091	-	DKC 0x.3-040-7																
	TPM(A) 050	110, 154, 220	-	DKC 0x.3-040-7	4000 8081	4000 8082	4000 8083	4000 8084	4000 8085	4000 8086	4000 8087	4000 8088	4000 8089	4000 8090	4000 8091	4000 8092	4000 8093	4000 8094	4000 8095	4000 8096
		021, 031	-	DKC 0x.3-100-7																
		021, 031, 061, 091	-	DKC 0x.3-040-7																
		110, 154, 220	-	DKC 0x.3-040-7																
		021, 031	-	DKC 0x.3-100-7																
		021, 031, 061, 091	-	DKC 0x.3-040-7																
TPM(A) 110	110, 154, 220	-	DKC 0x.3-040-7	4000 8081	4000 8082	4000 8083	4000 8084	4000 8085	4000 8086	4000 8087	4000 8088	4000 8089	4000 8090	4000 8091	4000 8092	4000 8093	4000 8094	4000 8095	4000 8096	
	021, 031	-	DKC 0x.3-100-7																	
	021, 031, 061, 091	-	DKC 0x.3-040-7																	
	110, 154, 220	-	DKC 0x.3-040-7																	
	021, 031	-	DKC 0x.3-100-7																	
	021, 031, 061, 091	-	DKC 0x.3-040-7																	

¹ WMC recommendation is based on use of a power stage with maximal PWM-frequency. Please refer to WMC or controller manufacture to select optimized controller size for the application. Possibly you are able to use a smaller controller.

Power and Feedback cables for TPM with EnDat absolute feedback ECN1313 / EQN1325

all cable complete and for dynamic laying

power cable TPM 004-050

KABELL-TPM_XXINDE-END015-STG

structure power cable: 4 x 1,5mm² + 2 x 1mm², diameter 12mm, min. bending radius 120mm

power cable TPM 110

KABELL-TPM_XXINDE-END025-STG

structure power cable: 4 x 2,5mm² + 2 x 1mm², diameter 15,1mm, min. bending radius 151mm

feedback cable

KABELS-TPM_XXINDE-END000-STG

structure feedback cable: 3 x (2 x 0,14mm²) + 4 x 0,14mm² + 4 x 0,25mm² + 2 x 0,5mm²; diameter 10mm diameter 10mm; min. bending radius 100mm

(xx = cable length)