

TPM⁺

Siemens SINAMICS S120

Quick Startup Guide

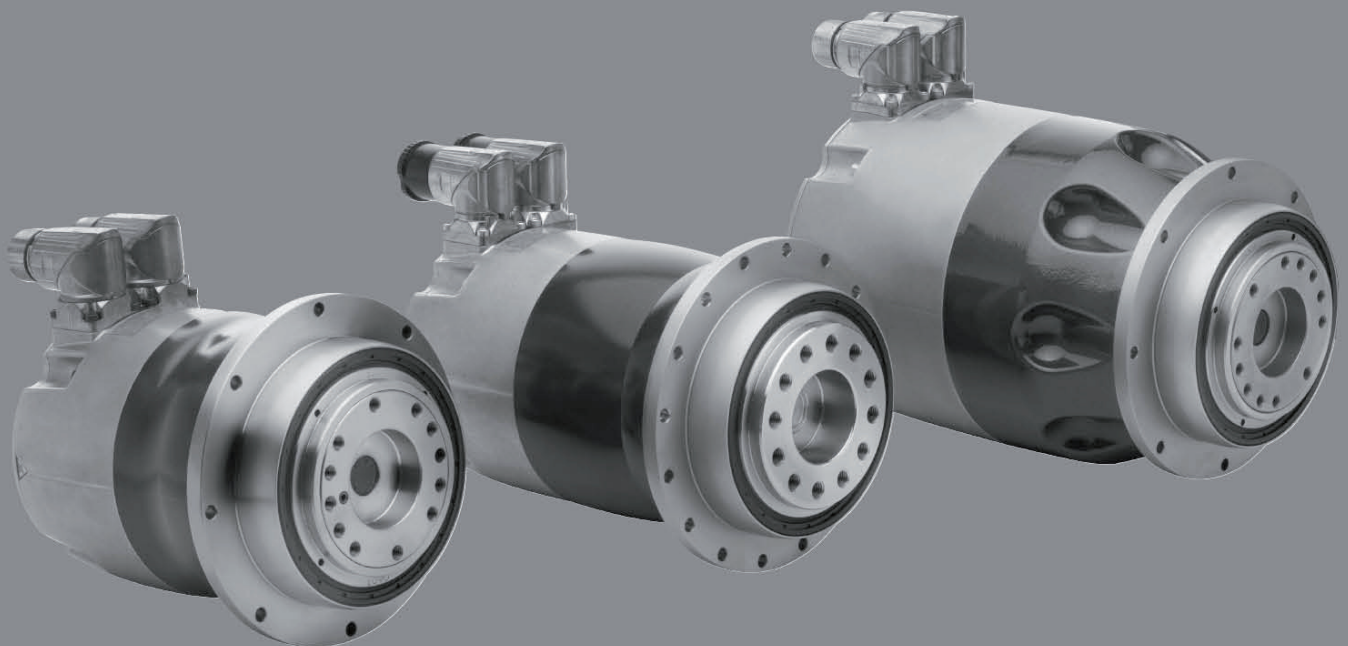

Revision history

Revision	Date	Comment	Chapter
01	27 th July 2012	First release	All
02	27 th March 2017	Transition to Wittenstein alpha	All

Service

In case you have technical questions,
please contact:

WITTENSTEIN alpha GmbH

Customer Service

Walter-Wittenstein-Straße 1

D-97999 Igersheim

Tel.: +49 (0) 79 31 / 493- 12900

Fax: +49 (0) 79 31 / 493- 10903

E-Mail: service@wittenstein.de

© WITTENSTEIN alpha GmbH 2017

This documentation is copyright protected.

WITTENSTEIN alpha GmbH reserves all the rights to photo-mechanical reproduction, copying, and the distribution by special processes (such as computers, file media, data networks), even in parts.

Subject to technical and content changes without notice.

Table of Contents

Revision history	1
1 General Information	4
1.1 Description, designations.....	4
1.2 Whom does this manual concern?.....	4
1.3 Which signs and symbols are referred to in this manual?.....	4
1.4 Exclusion of liability.....	4
1.5 EC low-voltage directive / EMC regulations.....	4
1.6 Copyright	4
2 Safety	5
2.1 Intended use.....	5
2.2 Improper use.....	5
2.3 Safety Instructions	5
3 Type plate information – identification	7
3.1 Identification plate, designation.....	7
4 Setting the parameters	8
4.1 Configuration Encoder TPM ⁺ Resolver.....	9
4.2 Configuration Encoder TPM ⁺ Heidenhain EnDat Multiturn or Singleturn	9
4.3 Configuration Encoder TPM ⁺ incremental encoder Heidenhain ERN1185	9
4.4 Parameter TPM+ Dynamic 004 560V	10
4.5 Parameter TPM+ Dynamic 010 560V	11
4.6 Parameter TPM+ Dynamic 025 560V	12
4.7 Parameter TPM+ Dynamic 050 560V	13
4.8 Parameter TPM+ Dynamic 110 560V	14
4.9 Parameter TPM+ Power 004 560V.....	15
4.10 Parameter TPM+ Power 010 560V	16
4.11 Parameter TPM+ Power 025 560V.....	17
4.12 Parameter TPM+ Power 050 560V.....	18
4.13 Parameter TPM+ Power 110 560V.....	19
4.14 Parameter TPM+ High Torque 010 560V	20
4.15 Parameter TPM+ High Torque 025 560V	21
4.16 Parameter TPM+ High Torque 050 560V	22
4.17 Parameter TPM+ High Torque 110 560V	23



- 5 Connection schematic TPM+ 24**
- 5.1 TPM+ with resolver..... 24
- 5.2 TPM+ with absolute encoder Heidenhain EnDat EQN 1125 25
- 5.3 TPM+ with incremental encoder Heidenhain ERN1185 26

1 General Information

1.1 Description, designations

The AC servo actuator **TPM⁺** (hereafter referred to as servo actuator) is a combination of a low-backlash planetary gearhead and an AC servo motor. The following manual contains the following points:

- Safety Instructions
- Parameter lists for the **TPM⁺** series
- Connection schematic for **TPM⁺**

1.2 Whom does this manual concern?

This manual concerns all persons who install, operate, or maintain this servo actuator.

They may only carry out work on the servo actuator, if they have read and understood this operating manual. Please pass the safety instructions on to other persons as well.

1.3 Which signs and symbols are referred to in this manual?

- ➔ An “action instruction”, which requires you to carry out an action.
- ▽ With a “check” you can specify whether the device is ready for the next work stage.
- ☺ A “usage tip” shows you an option of facilitating or improving operations.

The safety instructions symbols are described in section [2 “Safety”](#).

1.4 Exclusion of liability

WITTENSTEIN alpha is not liable for damages or injury caused by:

- Improper utilization of the servo actuator and the servo amplifier or
- Incorrect setting of operating parameters.

1.5 EC low-voltage directive / EMC regulations

The servo actuator has been constructed in accordance with EC directive 73/23/EEC. During installation and connection of the electrical components, the relevant regulations have to be observed (for example wire cross sections, fuse protection, etc.). Meeting all requirements for the entire system is the responsibility of the system's manufacturer.

You may only operate the equipment if you comply to the national EMC regulations (refer to the servo amplifier documentation for installation information pertaining to EMC) as they are defined for the given application.

1.6 Copyright

© 2017, **WITTENSTEIN alpha GmbH**

All of the product brand names which appear in this manual are trademarks of the relevant companies. If the ® and/or TM symbols are omitted, this does imply that the name is a free brand name.

2 Safety

2.1 Intended use

The servo actuator is designed for industrial applications. Its purpose is to drive machines. Please refer to our catalogue or our Internet page for the maximum permitted speeds and torques: www.wittenstein-alpha.de

- ➔ Please consult our technical service if your servo actuator is more than a year old. In this way you receive valid data.
- ➔ Please be sure to read the documentation provided by the manufacturer of the servo actuator.

2.2 Improper use

Any use transgressing the above-named restrictions (especially higher torques and speeds) is not compliant with the regulations, and is thus prohibited.

The operation of the servo actuator is prohibited if:

- It was not installed according to regulations (for example fastening bolts).
- The servo actuator is very dirty, damaged or blocked.
- It is operated without lubricant.
- The cables are damaged or improperly connected.
- The operating parameters have not been set properly.

2.3 Safety Instructions

The following symbols are used in this manual to warn you of hazards:



DANGER!

This symbol warns you of danger of injury to yourself and others.



Attention

This symbol warns you of the risk of damage to the servo actuator.



Environment

This symbol warns of environmental pollution risk.

2.3.1 General safety instructions

Working on the servo actuator



DANGER!

Improperly executed work can lead to injury and damage.

- ➔ Always ensure that the servo actuator is only installed, maintained, and dismantled by trained technicians.

**DANGER!**

Current-flow through the body or arcing can lead to grave injury and death.

- Only perform tasks on the electrical system if you are:
 - A trained electrician.
 - A person trained in electro-technology, working under the supervision of a specialist electrician.
- Always adhere to the five safety rules for the de-energised state:
 - De-energise.
 - Secure against being turned on (for example by locking it).
 - Ensure that de-energised state exists.
 - Attach ground line and short-circuit the equipment.
 - Cover and safeguard any live parts in the immediate vicinity.

**DANGER!**

Impurities spinning through the air can cause grave injury.

- Before putting the servo actuator into operation, check that there are no impurities or tools near it.

Maintenance**DANGER!**

An unintentional start of the machine during maintenance work can lead to serious accidents.

- Ensure that no one can start the machine while you are working on it.

**DANGER!**

Even only briefly running the machine during maintenance work can lead to accidents if the safety devices are not operating.

- Check that all safety devices have been mounted and are activated.

Wiring**DANGER!**

Incorrect wiring can lead to injuries and damage.

- Only use power and signal cables recommended by WITTENSTEIN alpha.
- Do not cut off power and signal cables, and do not insert extensions.
- Make sure that the U-U, V-V and W-W motor phases are correctly connected.
- Make sure that the motor encoder interface of the servo controller is compatible to the servo actuator.
- Observe the prescribed voltage for the brakes (usually 24 V DC) and the polarity.

3 Type plate information – identification

- ➔ The technical specifications can be found on your servo actuator's type plate according to the following scheme.

3.1 Identification plate, designation

The following specifications can be found on the identification plate:

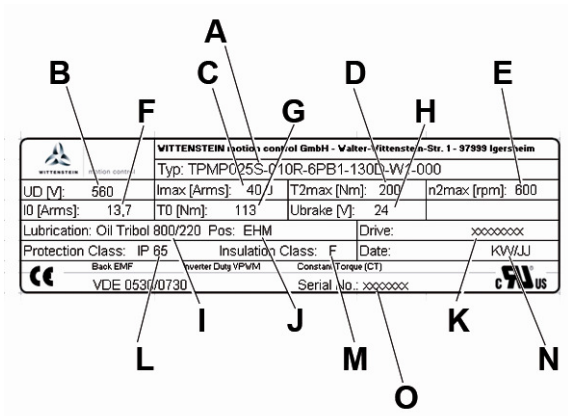

- A Ordering code
- B DC-Bus voltage
- C Maximum current
- D Maximum torque at gear output
- E Maximum gear output speed
- F Continuous stall current
- G Continuous stall torque at gear output
- H Brake voltage
- I Lubricant
- J Mounting position
- K For use with drive
- L Type of protection
- M Insulation class
- N Manufacturing date
- O Serial number

Bild 4.2

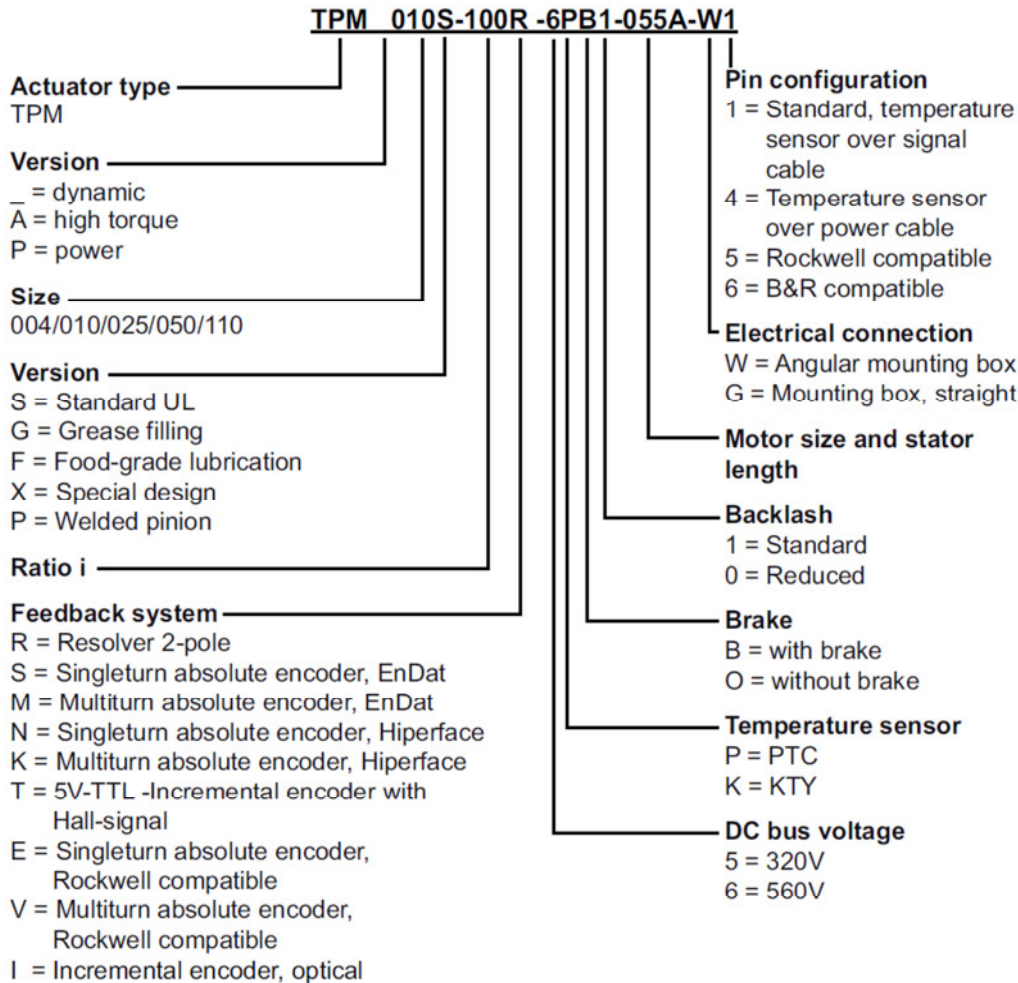

4 Setting the parameters

The tables in chapter [4](#) contain all of the parameters that are required for the initial start-up of a **TPM⁺** servo actuator from WITTENSTEIN alpha at a servo drive **Siemens Sinamics S120**.

The parameters can be entered with the Siemens STARTER software in the dialog “Drive navigator – Device configuration – Carry out drive configuration”.

In the dialog “Calculation of the motor/controller data” enable the checkbox “Complete calculation without equiv. circuit diag. data”.

When the servo actuator and the servo drive are properly connected, these parameters guarantee that the servo actuator can be operated at idle with speed control.

Based on these default settings, you can optimize the dynamics of the speed controller depending on the application.

Follow the details of the type plate.

Data for combinations not shown here are available on demand.

4.1 Configuration Encoder TPM⁺ Resolver

In the dialog "Configuration - Encoder" of the drive configuration assistant the following settings have to be done:

Encoder name: Resolver
Encoder evaluation: SMC10 xxx
Enable the checkbox „Enter data“

Click on the button „Encoder data“. Enter the following data in the dialog „Encoder data“:

Measuring system: Resolver
No. of pole pairs: 1

4.2 Configuration Encoder TPM⁺ Heidenhain EnDat Multiturn

In the dialog "Configuration - Encoder" of the drive configuration assistant select the code number **2053 512, 1Vpp, A/B, EnDat, Multiturn 4096**.

If encoder 2053 is not included in the list the following settings have to be entered manually:

Encoder name: EnDat
Encoder evaluation: SMC20 xxx
Enable the checkbox „Enter data“

Click on the button „Encoder data“. Enter the following data in the dialog „Encoder data“:

Measuring system: Absolute EnDat protocol
Enable the checkbox „Identify encoder“

4.3 Configuration Encoder TPM⁺ incremental encoder Heidenhain ERN1185

In the dialog "Configuration - Encoder" of the drive configuration assistant the following settings have to be done:

Encoder name: Incremental
Encoder evaluation: SMC20 xxx
Enable the checkbox „Enter data“

Click on the button „Encoder data“. Enter the following data in the dialog „Encoder data“:

Measuring system: Incremental sine/cosine
Pulses/revolution: 2048
Encoder type: Incremental – one zero mark
Commutation information: Coarse synchronisation with C/D track

4.4 Parameter TPM+ Dynamic 004 560V

Execute "Complete calculation without equiv. circuit diag. data" after input.

Code	Description	Unit	i=16-31 560 VDC	i=61-91 560 VDC
p305	Rated motor current	Arms	1,10	0,80
p311	Rated motor velocity	rpm	5000	5000
p314	Motor pole pair number	-	4	4
p316	Motor torque constant	Nm/Arms	0,70	0,47
p322	Maximum motor speed	rpm	6000	6000
p323	Maximum motor current	Arms	See table below	
p338	Motor limit current	Arms	See table below	
p341	Motor moment of inertia	kgm ²	See table below	
p350	Motor stator resistance, cold	Ohm	14,10	18,70
p356	Motor stator leakage inductance	mH	16,65	15,00
p312	Rated motor torque	Nm	0,72	0,36
p317	Motor voltage constant	Volt	42,2	28,3
p318	Motor stall current	Arms	1,10	0,80
p319	Motor stall torque	Nm	0,72	0,36
p391	Current controller adaptation, lower starting point	Arms	1,1	0,8
p392	Current controller adaptation, upper starting point	Arms	3,2	2,4
p393	Current controller adaptation, P gain, scaling upper	%	89	87
p1215 ¹	Motor holding brake configuration	-	1	1
p1216	Motor holding brake opening time	ms	12	12
p1217	Motor holding brake closing time	ms	10	10

¹ For actuators without holding brake the parameter p1215 has to be set to 0.

Ratio	Motor inertia w/o brake[kgm ²]	Motor inertia with brake[kgm ²]	I _{max stat} [A _{rms}] ²	I _{max dyn} [A _{rms}] ³
16	0,000021	0,000023	3,20	3,20
21	0,000020	0,000023	2,60	3,20
31	0,000020	0,000022	2,20	3,20
61	0,000012	0,000014	1,40	2,40
64	0,000011	0,000013	1,30	2,40
91	0,000012	0,000014	0,90	2,40

² Static maximum motorcurrent: Use this maximum current to protect the gear reducer from overload and to reduce the torque safely to T2B.

³ Dynamic maximum motorcurrent: For dynamic applications the maximum current can be increased to this value in dependency of the mass moment of inertia relation. We recommend a detailed calculation with Cymex.

4.5 Parameter TPM+ Dynamic 010 560V

Execute "Complete calculation without equiv. circuit diag. data" after input.

Code	Description	Unit	i=16-31 560 VDC	i=61-91 560 VDC
p305	Rated motor current	Arms	1,30	0,90
p311	Rated motor velocity	rpm	5000	5000
p314	Motor pole pair number	-	4	4
p316	Motor torque constant	Nm/Arms	0,97	0,78
p322	Maximum motor speed	rpm	6000	6000
p323	Maximum motor current	Arms	See table below	
p338	Motor limit current	Arms	See table below	
p341	Motor moment of inertia	kgm ²	See table below	
p350	Motor stator resistance, cold	Ohm	10,65	20,00
p356	Motor stator leakage inductance	mH	11,40	15,00
p312	Rated motor torque	Nm	1,20	0,67
p317	Motor voltage constant	Volt	58,5	47,4
p318	Motor stall current	Arms	1,30	0,90
p319	Motor stall torque	Nm	1,20	0,67
p391	Current controller adaptation, lower starting point	Arms	1,3	0,9
p392	Current controller adaptation, upper starting point	Arms	5,2	3,0
p393	Current controller adaptation, P gain, scaling upper	%	75	81
p1215 ¹	Motor holding brake configuration	-	1	1
p1216	Motor holding brake opening time	ms	12	12
p1217	Motor holding brake closing time	ms	10	10

¹ For actuators without holding brake the parameter p1215 has to be set to 0.

Ratio	Motor inertia w/o brake[kgm ²]	Motor inertia with brake[kgm ²]	$I_{\max \text{ stat}}$ [A _{rms}] ²	$I_{\max \text{ dyn}}$ [A _{rms}] ³
16	0,000032	0,000034	5,20	5,20
21	0,000032	0,000034	5,20	5,20
31	0,000032	0,000034	4,70	5,20
61	0,000017	0,000019	2,20	3,00
64	0,000017	0,000019	2,10	3,00
91	0,000017	0,000019	1,50	3,00

² Static maximum motorcurrent: Use this maximum current to protect the gear reducer from overload and to reduce the torque safely to T2B.

³ Dynamic maximum motorcurrent: For dynamic applications the maximum current can be increased to this value in dependency of the mass moment of inertia relation. We recommend a detailed calculation with Cymex.

4.6 Parameter TPM+ Dynamic 025 560V

Execute "Complete calculation without equiv. circuit diag. data" after input.

Code	Description	Unit	i=16-31 560 VDC	i=61-91 560 VDC
p305	Rated motor current	Arms	5,70	1,90
p311	Rated motor velocity	rpm	5000	5000
p314	Motor pole pair number	-	6	6
p316	Motor torque constant	Nm/Arms	0,98	1,02
p322	Maximum motor speed	rpm	6000	6000
p323	Maximum motor current	Arms	See table below	
p338	Motor limit current	Arms	See table below	
p341	Motor moment of inertia	kgm ²	See table below	
p350	Motor stator resistance, cold	Ohm	1,10	6,75
p356	Motor stator leakage inductance	mH	3,00	9,45
p312	Rated motor torque	Nm	5,50	1,86
p317	Motor voltage constant	Volt	59,5	61,3
p318	Motor stall current	Arms	5,70	1,90
p319	Motor stall torque	Nm	5,50	1,86
p391	Current controller adaptation, lower starting point	Arms	5,7	1,9
p392	Current controller adaptation, upper starting point	Arms	17,0	6,0
p393	Current controller adaptation, P gain, scaling upper	%	73	72
p1215 ¹	Motor holding brake configuration	-	1	1
p1216	Motor holding brake opening time	ms	30	30
p1217	Motor holding brake closing time	ms	20	20

¹ For actuators without holding brake the parameter p1215 has to be set to 0.

Ratio	Motor inertia w/o brake[kgm ²]	Motor inertia with brake[kgm ²]	I _{max stat} [A _{rms}] ²	I _{max dyn} [A _{rms}] ³
16	0,000216	0,000235	17,00	17,00
21	0,000216	0,000235	17,00	17,00
31	0,000217	0,000236	14,10	17,00
61	0,000077	0,000096	5,90	6,00
64	0,000076	0,000095	5,60	6,00
91	0,000076	0,000095	3,80	6,00

² Static maximum motorcurrent: Use this maximum current to protect the gear reducer from overload and to reduce the torque safely to T2B.

³ Dynamic maximum motorcurrent: For dynamic applications the maximum current can be increased to this value in dependency of the mass moment of inertia relation. We recommend a detailed calculation with Cymex.

4.7 Parameter TPM+ Dynamic 050 560V

Execute "Complete calculation without equiv. circuit diag. data" after input.

Code	Description	Unit	i=16-31 560 VDC	i=61-91 560 VDC
p305	Rated motor current	Arms	13,70	3,80
p311	Rated motor velocity	rpm	4167	4167
p314	Motor pole pair number	-	6	6
p316	Motor torque constant	Nm/Arms	1,00	0,97
p322	Maximum motor speed	rpm	5000	5000
p323	Maximum motor current	Arms	See table below	
p338	Motor limit current	Arms	See table below	
p341	Motor moment of inertia	kgm ²	See table below	
p350	Motor stator resistance, cold	Ohm	0,22	2,00
p356	Motor stator leakage inductance	mH	1,50	5,55
p312	Rated motor torque	Nm	13,49	3,59
p317	Motor voltage constant	Volt	61,0	58,7
p318	Motor stall current	Arms	13,70	3,80
p319	Motor stall torque	Nm	13,49	3,59
p391	Current controller adaptation, lower starting point	Arms	13,7	3,8
p392	Current controller adaptation, upper starting point	Arms	40,0	12,0
p393	Current controller adaptation, P gain, scaling upper	%	72	67
p1215 ¹	Motor holding brake configuration	-	1	1
p1216	Motor holding brake opening time	ms	42	42
p1217	Motor holding brake closing time	ms	20	20

¹ For actuators without holding brake the parameter p1215 has to be set to 0.

Ratio	Motor inertia w/o brake[kgm ²]	Motor inertia with brake[kgm ²]	I _{max stat} [A _{rms}] ²	I _{max dyn} [A _{rms}] ³
16	0,000907	0,001007	40,00	40,00
21	0,000907	0,001007	34,30	40,00
31	0,000894	0,000993	29,40	40,00
61	0,000251	0,000351	12,00	12,00
64	0,000249	0,000349	12,00	12,00
91	0,000249	0,000349	8,40	12,00

² Static maximum motorcurrent: Use this maximum current to protect the gear reducer from overload and to reduce the torque safely to T2B.

³ Dynamic maximum motorcurrent: For dynamic applications the maximum current can be increased to this value in dependency of the mass moment of inertia relation. We recommend a detailed calculation with Cymex.

4.8 Parameter TPM+ Dynamic 110 560V

Execute "Complete calculation without equiv. circuit diag. data" after input.

Code	Description	Unit	i=16-31 560 VDC	i=61-91 560 VDC
p305	Rated motor current	Arms	16,70	13,70
p311	Rated motor velocity	rpm	4167	4167
p314	Motor pole pair number	-	6	6
p316	Motor torque constant	Nm/Arms	1,00	1,00
p322	Maximum motor speed	rpm	5000	5000
p323	Maximum motor current	Arms	See table below	
p338	Motor limit current	Arms	See table below	
p341	Motor moment of inertia	kgm ²	See table below	
p350	Motor stator resistance, cold	Ohm	0,16	0,22
p356	Motor stator leakage inductance	mH	1,20	1,50
p312	Rated motor torque	Nm	16,42	13,49
p317	Motor voltage constant	Volt	61,0	61,0
p318	Motor stall current	Arms	16,70	13,70
p319	Motor stall torque	Nm	16,42	13,49
p391	Current controller adaptation, lower starting point	Arms	16,7	13,7
p392	Current controller adaptation, upper starting point	Arms	70,0	40,0
p393	Current controller adaptation, P gain, scaling upper	%	63	72
p1215 ¹	Motor holding brake configuration	-	1	1
p1216	Motor holding brake opening time	ms	42	42
p1217	Motor holding brake closing time	ms	20	20

¹ For actuators without holding brake the parameter p1215 has to be set to 0.

Ratio	Motor inertia w/o brake[kgm ²]	Motor inertia with brake[kgm ²]	I _{max stat} [A _{rms}] ²	I _{max dyn} [A _{rms}] ³
16	0,001314	0,001414	70,00	70,00
21	0,001314	0,001414	70,00	70,00
31	0,001284	0,001384	70,00	70,00
61	0,000889	0,000988	30,00	40,00
64	0,000883	0,000983	28,30	40,00
91	0,000883	0,000983	18,00	40,00

² Static maximum motorcurrent: Use this maximum current to protect the gear reducer from overload and to reduce the torque safely to T2B.

³ Dynamic maximum motorcurrent: For dynamic applications the maximum current can be increased to this value in dependency of the mass moment of inertia relation. We recommend a detailed calculation with Cymex.

4.9 Parameter TPM+ Power 004 560V

Execute "Complete calculation without equiv. circuit diag. data" after input.

Code	Description	Unit	i=4-35 560 VDC	i=40-100 560 VDC
p305	Rated motor current	Arms	1,56	1,00
p311	Rated motor velocity	rpm	5000	5000
p314	Motor pole pair number	-	4	4
p316	Motor torque constant	Nm/Arms	0,97	0,78
p322	Maximum motor speed	rpm	6000	6000
p323	Maximum motor current	Arms	See table below	
p338	Motor limit current	Arms	See table below	
p341	Motor moment of inertia	kgm ²	See table below	
p350	Motor stator resistance, cold	Ohm	10,65	20,00
p356	Motor stator leakage inductance	mH	11,40	15,00
p312	Rated motor torque	Nm	1,25	0,66
p317	Motor voltage constant	Volt	58,5	47,4
p318	Motor stall current	Arms	1,56	1,00
p319	Motor stall torque	Nm	1,25	0,66
p391	Current controller adaptation, lower starting point	Arms	1,6	1,0
p392	Current controller adaptation, upper starting point	Arms	5,2	3,0
p393	Current controller adaptation, P gain, scaling upper	%	75	81
p1215 ¹	Motor holding brake configuration	-	1	1
p1216	Motor holding brake opening time	ms	12	12
p1217	Motor holding brake closing time	ms	10	10

¹ For actuators without holding brake the parameter p1215 has to be set to 0.

Ratio	Motor inertia w/o brake[kgm ²]	Motor inertia with brake[kgm ²]	$I_{\max \text{ stat}}^2$ [A _{rms}] ²	$I_{\max \text{ dyn}}^3$ [A _{rms}] ³
4	0,000039	0,000041	5,20	5,20
5	0,000036	0,000038	5,20	5,20
7	0,000033	0,000035	5,20	5,20
10	0,000031	0,000034	3,60	5,20
16	0,000032	0,000034	4,40	5,20
20	0,000031	0,000034	3,50	5,20
25	0,000031	0,000034	2,80	5,20
28	0,000031	0,000033	2,50	5,20
35	0,000031	0,000033	1,90	5,20
40	0,000016	0,000018	2,10	3,00
50	0,000016	0,000018	1,70	3,00
70	0,000016	0,000018	1,20	3,00
100	0,000016	0,000018	0,60	3,00

² Static maximum motorcurrent: Use this maximum current to protect the gear reducer from overload and to reduce the torque safely to T2B.

³ Dynamic maximum motorcurrent: For dynamic applications the maximum current can be increased to this value in dependency of the mass moment of inertia relation. We recommend a detailed calculation with Cymex.

4.10 Parameter TPM+ Power 010 560V

Execute "Complete calculation without equiv. circuit diag. data" after input.

Code	Description	Unit	i=4-35 560 VDC	i=40-100 560 VDC
p305	Rated motor current	Arms	5,40	1,86
p311	Rated motor velocity	rpm	5000	5000
p314	Motor pole pair number	-	6	6
p316	Motor torque constant	Nm/Arms	0,98	1,02
p322	Maximum motor speed	rpm	6000	6000
p323	Maximum motor current	Arms	See table below	
p338	Motor limit current	Arms	See table below	
p341	Motor moment of inertia	kgm ²	See table below	
p350	Motor stator resistance, cold	Ohm	1,10	6,75
p356	Motor stator leakage inductance	mH	3,00	9,45
p312	Rated motor torque	Nm	4,50	1,38
p317	Motor voltage constant	Volt	59,5	61,3
p318	Motor stall current	Arms	5,40	1,86
p319	Motor stall torque	Nm	4,50	1,38
p391	Current controller adaptation, lower starting point	Arms	5,4	1,9
p392	Current controller adaptation, upper starting point	Arms	17,0	6,0
p393	Current controller adaptation, P gain, scaling upper	%	73	72
p1215 ¹	Motor holding brake configuration	-	1	1
p1216	Motor holding brake opening time	ms	30	30
p1217	Motor holding brake closing time	ms	20	20

¹ For actuators without holding brake the parameter p1215 has to be set to 0.

Ratio	Motor inertia w/o brake[kgm ²]	Motor inertia with brake[kgm ²]	I _{max stat} [A _{rms}] ²	I _{max dyn} ³ [A _{rms}] ³
4	0,000238	0,000257	17,00	17,00
5	0,000222	0,000241	17,00	17,00
7	0,000208	0,000227	17,00	17,00
10	0,000200	0,000219	12,20	17,00
16	0,000202	0,000221	11,50	17,00
20	0,000199	0,000218	8,90	17,00
25	0,000198	0,000217	6,90	17,00
28	0,000196	0,000215	6,00	17,00
35	0,000196	0,000214	4,70	17,00
40	0,000072	0,000091	4,70	6,00
50	0,000072	0,000091	3,70	6,00
70	0,000072	0,000091	2,70	6,00
100	0,000072	0,000091	1,50	6,00

² Static maximum motorcurrent: Use this maximum current to protect the gear reducer from overload and to reduce the torque safely to T2B.

³ Dynamic maximum motorcurrent: For dynamic applications the maximum current can be increased to this value in dependency of the mass moment of inertia relation. We recommend a detailed calculation with Cymex.

4.11 Parameter TPM+ Power 025 560V

Execute "Complete calculation without equiv. circuit diag. data" after input.

Code	Description	Unit	i=4-35 560 VDC	i=40-100 560 VDC
p305	Rated motor current	Arms	13,70	4,00
p311	Rated motor velocity	rpm	5000	5000
p314	Motor pole pair number	-	6	6
p316	Motor torque constant	Nm/Arms	1,00	0,97
p322	Maximum motor speed	rpm	6000	6000
p323	Maximum motor current	Arms	See table below	
p338	Motor limit current	Arms	See table below	
p341	Motor moment of inertia	kgm ²	See table below	
p350	Motor stator resistance, cold	Ohm	0,22	2,00
p356	Motor stator leakage inductance	mH	1,50	5,55
p312	Rated motor torque	Nm	11,68	3,00
p317	Motor voltage constant	Volt	61,0	58,7
p318	Motor stall current	Arms	13,70	4,00
p319	Motor stall torque	Nm	11,68	3,00
p391	Current controller adaptation, lower starting point	Arms	13,7	4,0
p392	Current controller adaptation, upper starting point	Arms	40,0	12,0
p393	Current controller adaptation, P gain, scaling upper	%	72	67
p1215 ¹	Motor holding brake configuration	-	1	1
p1216	Motor holding brake opening time	ms	42	42
p1217	Motor holding brake closing time	ms	20	20

¹ For actuators without holding brake the parameter p1215 has to be set to 0.

Ratio	Motor inertia w/o brake[kgm ²]	Motor inertia with brake[kgm ²]	$I_{\max \text{ stat}}$ [A _{rms}] ²	$I_{\max \text{ dyn}}$ ³ [A _{rms}] ³
4	0,000998	0,001098	40,00	40,00
5	0,000950	0,001050	40,00	40,00
7	0,000907	0,001007	40,00	40,00
10	0,000884	0,000984	27,00	40,00
16	0,000894	0,000994	29,90	40,00
20	0,000883	0,000982	23,10	40,00
25	0,000881	0,000980	19,50	40,00
28	0,000872	0,000972	15,30	40,00
35	0,000871	0,000971	13,00	40,00
40	0,000248	0,000348	12,00	12,00
50	0,000248	0,000348	12,00	12,00
70	0,000248	0,000347	7,10	12,00
100	0,000247	0,000347	3,70	12,00

² Static maximum motorcurrent: Use this maximum current to protect the gear reducer from overload and to reduce the torque safely to T2B.

³ Dynamic maximum motorcurrent: For dynamic applications the maximum current can be increased to this value in dependency of the mass moment of inertia relation. We recommend a detailed calculation with Cymex.

4.12 Parameter TPM+ Power 050 560V

Execute "Complete calculation without equiv. circuit diag. data" after input.

Code	Description	Unit	i=4-35 560 VDC	i=40-100 560 VDC
p305	Rated motor current	Arms	19,00	7,50
p311	Rated motor velocity	rpm	4167	4167
p314	Motor pole pair number	-	6	6
p316	Motor torque constant	Nm/Arms	1,19	0,91
p322	Maximum motor speed	rpm	5000	5000
p323	Maximum motor current	Arms	See table below	
p338	Motor limit current	Arms	See table below	
p341	Motor moment of inertia	kgm ²	See table below	
p350	Motor stator resistance, cold	Ohm	0,14	0,90
p356	Motor stator leakage inductance	mH	1,05	2,55
p312	Rated motor torque	Nm	19,30	5,40
p317	Motor voltage constant	Volt	71,9	55,1
p318	Motor stall current	Arms	19,00	7,50
p319	Motor stall torque	Nm	19,30	5,40
p391	Current controller adaptation, lower starting point	Arms	19,0	7,5
p392	Current controller adaptation, upper starting point	Arms	63,5	33,0
p393	Current controller adaptation, P gain, scaling upper	%	75	52
p1215 ¹	Motor holding brake configuration	-	1	1
p1216	Motor holding brake opening time	ms	50	50
p1217	Motor holding brake closing time	ms	40	40

¹ For actuators without holding brake the parameter p1215 has to be set to 0.

Ratio	Motor inertia w/o brake[kgm ²]	Motor inertia with brake[kgm ²]	I _{max stat} [A _{rms}] ²	I _{max dyn} ³ [A _{rms}] ³
4	0,002642	0,002822	63,50	63,50
5	0,002480	0,002660	63,50	63,50
7	0,002334	0,002514	54,90	63,50
10	0,002254	0,002434	38,40	63,50
16	0,002307	0,002487	53,10	63,50
20	0,002261	0,002441	41,70	63,50
25	0,002255	0,002435	32,60	63,50
28	0,002220	0,002400	28,60	63,50
35	0,002217	0,002397	22,20	63,50
40	0,00063	0,00081	33,00	33,00
50	0,000628	0,000808	32,50	33,00
70	0,000627	0,000807	19,90	33,00
100	0,000626	0,000806	8,30	33,00

² Static maximum motorcurrent: Use this maximum current to protect the gear reducer from overload and to reduce the torque safely to T2B.

³ Dynamic maximum motorcurrent: For dynamic applications the maximum current can be increased to this value in dependency of the mass moment of inertia relation. We recommend a detailed calculation with Cymex.

4.13 Parameter TPM+ Power 110 560V

Execute "Complete calculation without equiv. circuit diag. data" after input.

Code	Description	Unit	i=4-35 560 VDC	i=40-100 560 VDC
p305	Rated motor current	Arms	38,60	21,90
p311	Rated motor velocity	rpm	3500	3750
p314	Motor pole pair number	-	6	6
p316	Motor torque constant	Nm/Arms	1,09	1,08
p322	Maximum motor speed	rpm	4200	4500
p323	Maximum motor current	Arms	See table below	
p338	Motor limit current	Arms	See table below	
p341	Motor moment of inertia	kgm ²	See table below	
p350	Motor stator resistance, cold	Ohm	0,04	0,12
p356	Motor stator leakage inductance	mH	0,45	0,95
p312	Rated motor torque	Nm	36,90	20,74
p317	Motor voltage constant	Volt	66,1	65,3
p318	Motor stall current	Arms	38,60	21,90
p319	Motor stall torque	Nm	36,90	20,74
p391	Current controller adaptation, lower starting point	Arms	38,6	21,9
p392	Current controller adaptation, upper starting point	Arms	100,0	50,0
p393	Current controller adaptation, P gain, scaling upper	%	81	82
p1215 ¹	Motor holding brake configuration	-	1	1
p1216	Motor holding brake opening time	ms	200	200
p1217	Motor holding brake closing time	ms	50	50

¹ For actuators without holding brake the parameter p1215 has to be set to 0.

Ratio	Motor inertia w/o brake[kgm ²]	Motor inertia with brake[kgm ²]	$I_{\max \text{ stat}}^2$ [A _{rms}] ²	$I_{\max \text{ dyn}}^3$ [A _{rms}] ³
4	0,014173	0,015873	100,00	100,00
5	0,013191	0,014891	100,00	100,00
7	0,012300	0,014000	100,00	100,00
10	0,011812	0,013512	62,60	100,00
16	0,011699	0,013399	100,00	100,00
20	0,011670	0,013370	92,40	100,00
25	0,011630	0,013330	72,90	100,00
28	0,011505	0,013205	64,40	100,00
35	0,011485	0,013185	50,50	100,00
40	0,006023	0,007723	46,00	50,00
50	0,006013	0,007713	36,30	50,00
70	0,006004	0,007704	25,30	50,00
100	0,005999	0,007699	15,50	50,00

² Static maximum motorcurrent: Use this maximum current to protect the gear reducer from overload and to reduce the torque safely to T2B.

³ Dynamic maximum motorcurrent: For dynamic applications the maximum current can be increased to this value in dependency of the mass moment of inertia relation. We recommend a detailed calculation with Cymex.

4.14 Parameter TPM+ High Torque 010 560V

Execute "Complete calculation without equiv. circuit diag. data" after input.

Code	Description	Unit	i=22-110 560 VDC	i=154-220 560 VDC
p305	Rated motor current	Arms	4,99	1,92
p311	Rated motor velocity	rpm	4042	4042
p314	Motor pole pair number	-	6	6
p316	Motor torque constant	Nm/Arms	0,83	0,82
p322	Maximum motor speed	rpm	4850	4850
p323	Maximum motor current	Arms	See table below	
p338	Motor limit current	Arms	See table below	
p341	Motor moment of inertia	kgm ²	See table below	
p350	Motor stator resistance, cold	Ohm	1,18	7,85
p356	Motor stator leakage inductance	mH	3,00	9,45
p312	Rated motor torque	Nm	3,75	1,44
p317	Motor voltage constant	Volt	50,3	49,2
p318	Motor stall current	Arms	4,99	1,92
p319	Motor stall torque	Nm	3,75	1,44
p391	Current controller adaptation, lower starting point	Arms	5,0	1,9
p392	Current controller adaptation, upper starting point	Arms	17,0	6,0
p393	Current controller adaptation, P gain, scaling upper	%	85	89
p1215 ¹	Motor holding brake configuration	-	1	1
p1216	Motor holding brake opening time	ms	30	30
p1217	Motor holding brake closing time	ms	20	25

¹ For actuators without holding brake the parameter p1215 has to be set to 0.

Ratio	Motor inertia w/o brake[kgm ²]	Motor inertia with brake[kgm ²]	I _{max stat} [A _{rms}] ²	I _{max dyn} [A _{rms}] ³
22	0,000206	0,000225	15,00	17,00
27,5	0,000203	0,000222	11,90	17,00
38,5	0,000201	0,000220	8,40	17,00
55	0,000199	0,000218	5,80	17,00
66	-	-	-	-
88	0,000201	0,000220	3,70	17,00
110	0,000200	0,000219	3,00	17,00
154	0,000068	0,000087	2,20	6,00
220	0,000067	0,000086	1,60	6,00

² Static maximum motorcurrent: Use this maximum current to protect the gear reducer from overload and to reduce the torque safely to T2B.

³ Dynamic maximum motorcurrent: For dynamic applications the maximum current can be increased to this value in dependency of the mass moment of inertia relation. We recommend a detailed calculation with Cymex.

4.15 Parameter TPM+ High Torque 025 560V

Execute "Complete calculation without equiv. circuit diag. data" after input.

Code	Description	Unit	i=22-55 560 VDC	i=66-220 560 VDC
p305	Rated motor current	Arms	13,08	5,76
p311	Rated motor velocity	rpm	4042	4042
p314	Motor pole pair number	-	6	6
p316	Motor torque constant	Nm/Arms	0,98	0,83
p322	Maximum motor speed	rpm	4850	4850
p323	Maximum motor current	Arms	See table below	
p338	Motor limit current	Arms	See table below	
p341	Motor moment of inertia	kgm ²	See table below	
p350	Motor stator resistance, cold	Ohm	0,24	1,18
p356	Motor stator leakage inductance	mH	1,50	3,00
p312	Rated motor torque	Nm	10,92	4,19
p317	Motor voltage constant	Volt	59,2	50,3
p318	Motor stall current	Arms	13,08	5,76
p319	Motor stall torque	Nm	10,92	4,19
p391	Current controller adaptation, lower starting point	Arms	13,1	5,8
p392	Current controller adaptation, upper starting point	Arms	40,0	17,0
p393	Current controller adaptation, P gain, scaling upper	%	74	85
p1215 ¹	Motor holding brake configuration	-	1	1
p1216	Motor holding brake opening time	ms	42	30
p1217	Motor holding brake closing time	ms	20	20

¹ For actuators without holding brake the parameter p1215 has to be set to 0.

Ratio	Motor inertia w/o brake[kgm ²]	Motor inertia with brake[kgm ²]	I _{max stat} [A _{rms}] ²	I _{max dyn} [A _{rms}] ³
22	0,000901	0,001000	33,40	40,00
27,5	0,000883	0,000983	26,10	40,00
38,5	0,000874	0,000974	17,80	40,00
55	0,000869	0,000969	11,80	40,00
66	0,000203	0,000222	10,50	17,00
88	0,000196	0,000215	7,80	17,00
110	0,000193	0,000212	6,20	17,00
154	0,000191	0,000210	4,40	17,00
220	0,000189	0,000208	3,10	17,00

² Static maximum motorcurrent: Use this maximum current to protect the gear reducer from overload and to reduce the torque safely to T2B.

³ Dynamic maximum motorcurrent: For dynamic applications the maximum current can be increased to this value in dependency of the mass moment of inertia relation. We recommend a detailed calculation with Cymex.

4.16 Parameter TPM+ High Torque 050 560V

Execute "Complete calculation without equiv. circuit diag. data" after input.

Code	Description	Unit	i=22-55 560 VDC	i=66-220 560 VDC
p305	Rated motor current	Arms	17,93	12,60
p311	Rated motor velocity	rpm	3750	4042
p314	Motor pole pair number	-	6	6
p316	Motor torque constant	Nm/Arms	1,21	1,00
p322	Maximum motor speed	rpm	4500	4850
p323	Maximum motor current	Arms	See table below	
p338	Motor limit current	Arms	See table below	
p341	Motor moment of inertia	kgm ²	See table below	
p350	Motor stator resistance, cold	Ohm	0,14	0,24
p356	Motor stator leakage inductance	mH	1,05	1,50
p312	Rated motor torque	Nm	19,28	11,11
p317	Motor voltage constant	Volt	73,4	61,0
p318	Motor stall current	Arms	17,93	12,60
p319	Motor stall torque	Nm	19,28	11,11
p391	Current controller adaptation, lower starting point	Arms	17,9	12,6
p392	Current controller adaptation, upper starting point	Arms	63,5	40,0
p393	Current controller adaptation, P gain, scaling upper	%	74	72
p1215 ¹	Motor holding brake configuration	-	1	1
p1216	Motor holding brake opening time	ms	50	42
p1217	Motor holding brake closing time	ms	40	20

¹ For actuators without holding brake the parameter p1215 has to be set to 0.

Ratio	Motor inertia w/o brake[kgm ²]	Motor inertia with brake[kgm ²]	I _{max stat} ² [A _{rms}] ²	I _{max dyn} ³ [A _{rms}] ³
22	0,002380	0,002560	48,10	63,50
27,5	0,002335	0,002515	37,30	63,50
38,5	0,002299	0,002479	25,10	63,50
55	0,002281	0,002461	16,40	63,50
66	0,000923	0,001022	18,20	40,00
88	0,000904	0,001003	12,50	40,00
110	0,000884	0,000983	10,10	40,00
154	0,000874	0,000974	7,20	40,00
220	0,000869	0,000969	5,00	40,00

² Static maximum motorcurrent: Use this maximum current to protect the gear reducer from overload and to reduce the torque safely to T2B.

³ Dynamic maximum motorcurrent: For dynamic applications the maximum current can be increased to this value in dependency of the mass moment of inertia relation. We recommend a detailed calculation with Cymex.

4.17 Parameter TPM+ High Torque 110 560V

Execute "Complete calculation without equiv. circuit diag. data" after input.

Code	Description	Unit	i=22-55 560 VDC	i=66-88 560 VDC	i=110-220 560 VDC
p305	Rated motor current	Arms	Tbd	40,85	20,50
p311	Rated motor velocity	rpm	3458	3458	3750
p314	Motor pole pair number	-	6	6	6
p316	Motor torque constant	Nm/Arms	1,17	1,09	1,19
p322	Maximum motor speed	rpm	4150	4150	4500
p323	Maximum motor current	Arms	See table below		
p338	Motor limit current	Arms	See table below		
p341	Motor moment of inertia	kgm ²	See table below		
p350	Motor stator resistance, cold	Ohm	0,02	0,04	0,14
p356	Motor stator leakage inductance	mH	0,34	0,45	1,05
p312	Rated motor torque	Nm	tbd	40,35	22,18
p317	Motor voltage constant	Volt	70,9	66,1	71,9
p318	Motor stall current	Arms	tbd	40,85	20,50
p319	Motor stall torque	Nm	tbd	40,35	22,18
p391	Current controller adaptation, lower starting point	Arms	53,7	40,8	20,5
p392	Current controller adaptation, upper starting point	Arms	160,0	100,0	63,5
p393	Current controller adaptation, P gain, scaling upper	%	88	81	75
p1215 ¹	Motor holding brake configuration	-	1	1	1
p1216	Motor holding brake opening time	ms	200	200	50
p1217	Motor holding brake closing time	ms	50	50	40

¹ For actuators without holding brake the parameter p1215 has to be set to 0.

Ratio	Motor inertia w/o brake[kgm ²]	Motor inertia with brake[kgm ²]	I _{max stat} [A _{rms}] ²	I _{max dyn} [A _{rms}] ³
22	0,022037	0,023687	tbd	tbd
27,5	0,021891	0,023541	tbd	tbd
38,5	0,021763	0,023413	tbd	tbd
55	0,021694	0,023344	tbd	tbd
66	0,011182	0,012882	40,50	100,00
88	0,010824	0,012524	30,40	100,00
110	0,002286	0,002466	23,00	63,50
154	0,002248	0,002428	15,90	63,50
220	0,002225	0,002405	11,20	63,50

² Static maximum motorcurrent: Use this maximum current to protect the gear reducer from overload and to reduce the torque safely to T2B.

³ Dynamic maximum motorcurrent: For dynamic applications the maximum current can be increased to this value in dependency of the mass moment of inertia relation. We recommend a detailed calculation with Cymex.

5 Connection schematic TPM⁺

- Detailed information on cable design and the type of shielding can be found in the documentation from the servo drive manufacturer.
- When using the cables from Wittenstein alpha a connector from Siemens is required to connect the cable to the Sinamics power module.

To connect the motor feedback to the Siemens DRIVE-CLiQ bus the SMC10(Siemens article 6SL3055-0AA00-5AA3) for Resolver resp. the SMC20(Siemens article 6SL3055-0AA00-5BA3) for absolute EnDat or incremental feedback is required.



5.1 TPM⁺ with resolver

WITTENSTEIN alpha offers pre-manufactured and drag chain compatible cablesets for this servo drive. Please take the required order informations from the TPM+ catalogue.

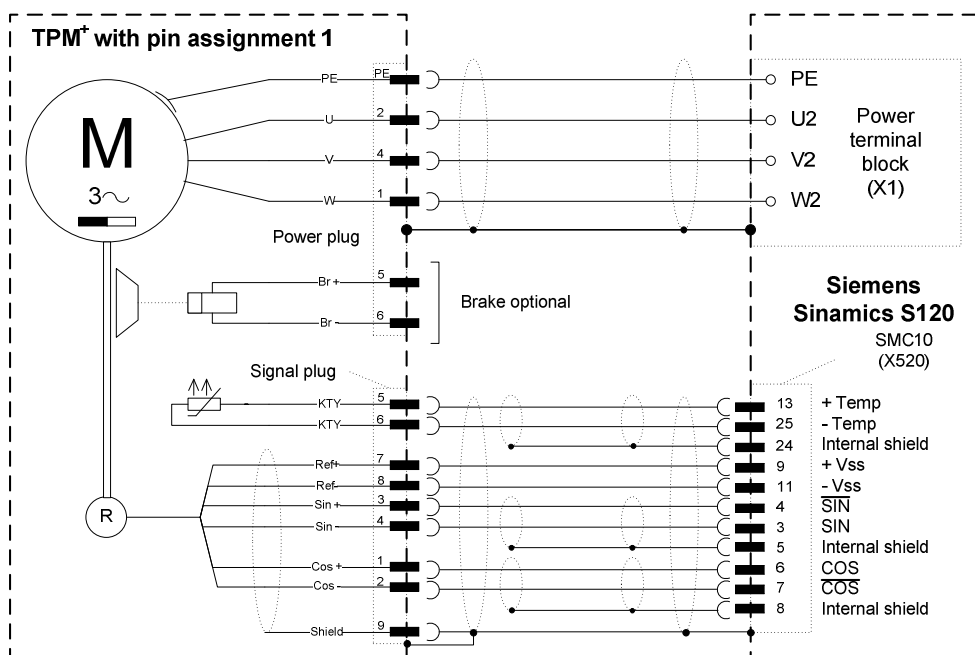

5.2 TPM+ with absolute encoder Heidenhain EnDat EQN 1125

WITTENSTEIN alpha offers pre-manufactured and drag chain compatible cablesets for this servo drive. Please take the required order informations from the TPM+ catalogue.

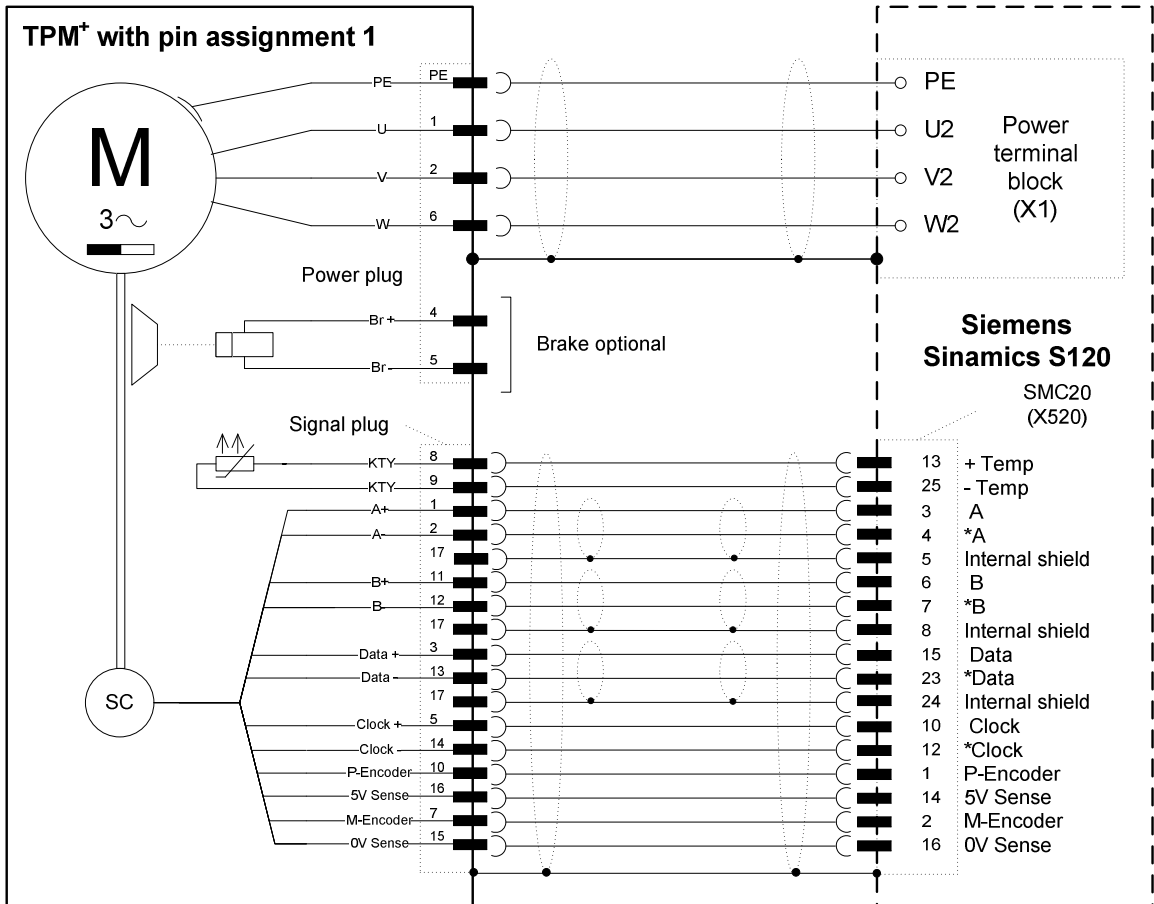

5.3 TPM+ with incremental encoder Heidenhain ERN1185

WITTENSTEIN alpha offers pre-manufactured and drag chain compatible cables for this servo drive. Please take the required order information from the TPM+ catalogue.

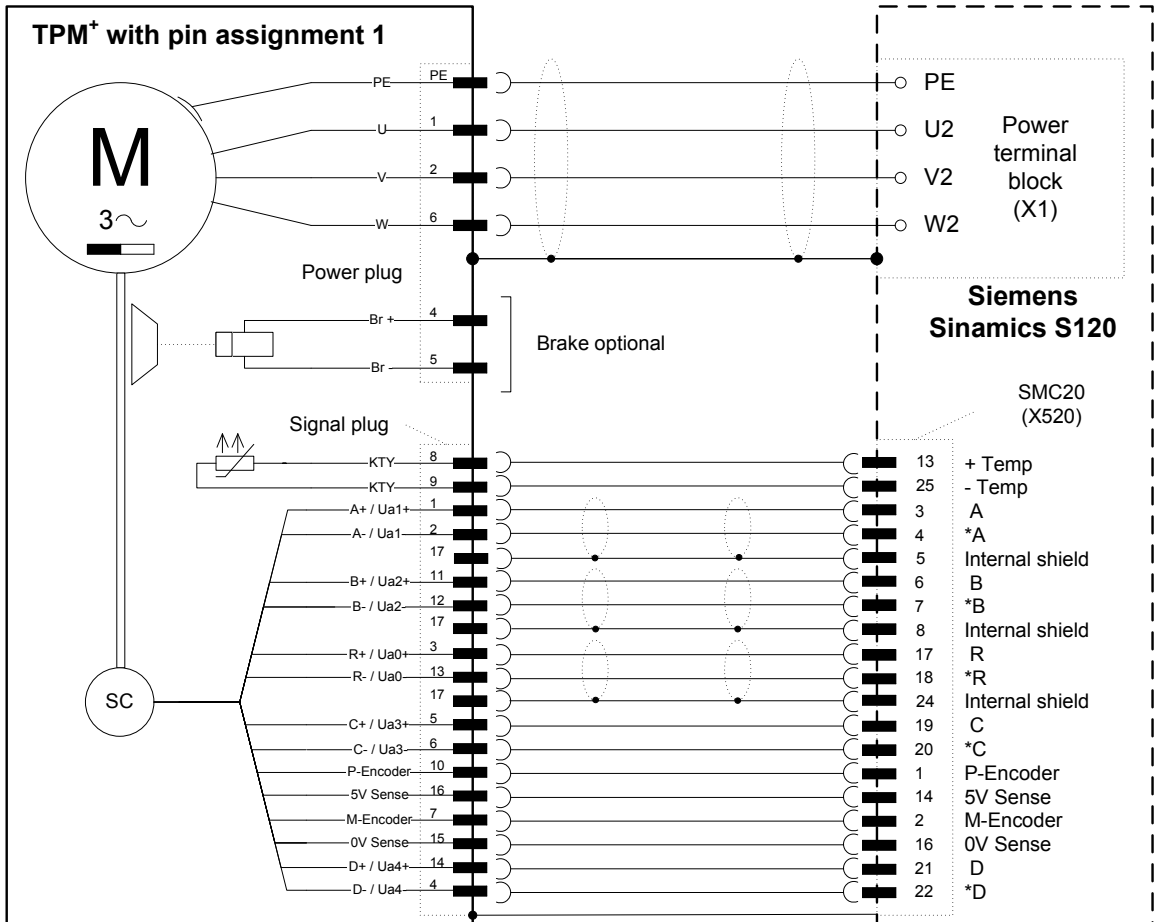



alpha

WITTENSTEIN alpha GmbH · Walter-Wittenstein-Straße 1 · 97999 Igersheim · Germany
Tel. +49 7931 493-12900 · info@wittenstein.de

WITTENSTEIN - one with the future

www.wittenstein-alpha.de