

axenia value Generation 2 Servo actuator in Hygienic Design

Technical documents

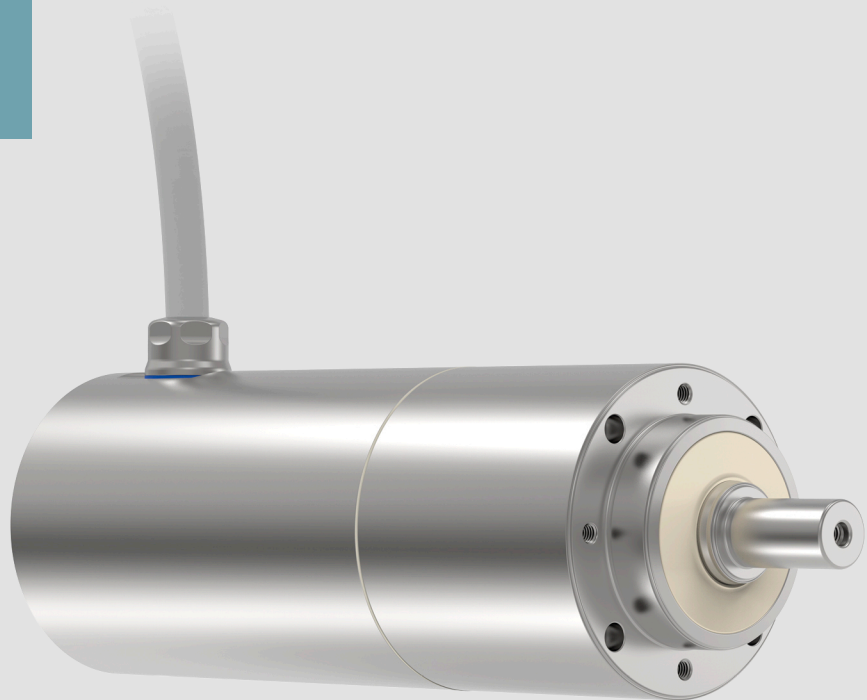

WITTENSTEIN alpha GmbH
 Walter-Wittenstein-Str. 1
 D-97999 Igersheim
 Germany

Customer Service

		✉)
Deutschland	WITTENSTEIN alpha GmbH	service@wittenstein.de	+49 7931 493-12900
Benelux	WITTENSTEIN BVBA	service@wittenstein.biz	+32 9 326 73 80
Brasil	WITTENSTEIN do Brasil	vendas@wittenstein.com.br	+55 15 3411 6454
中国	威騰斯坦（杭州）实业有限公司	service@wittenstein.cn	+86 571 8869 5856
Österreich	WITTENSTEIN GmbH	office@wittenstein.at	+43 2256 65632-0
Danmark	WITTENSTEIN AB	info@wittenstein.dk	+45 4027 4151
France	WITTENSTEIN sarl	info@wittenstein.fr	+33 134 17 90 95
Great Britain	WITTENSTEIN Ltd.	sales.uk@wittenstein.co.uk	+44 1782 286 427
Italia	WITTENSTEIN S.P.A.	customerservice@wittenstein.it	+39 02 241357-1
日本	ヴィッテンシュタイン株式会社	sales@wittenstein.jp	+81-3-6680-2835
North America	WITTENSTEIN holding Corp.	technicalsupport@wittenstein-us.com	+1 630-540-5300
España	WITTENSTEIN S.L.U.	info@wittenstein.es	+34 93 479 1305
Sverige	WITTENSTEIN AB	info@wittenstein.se	+46 40-26 50 10
Schweiz	WITTENSTEIN AG Schweiz	sales@wittenstein.ch	+41 81 300 10 30
台湾	威騰斯坦有限公司	info@wittenstein.tw	+886 3 287 0191
Türkiye	WITTENSTEIN Güç Aktarma Sistemleri Tic. Ltd. Şti.	info@wittenstein.com.tr	+90 216 709 21 23

Table of Contents

- 1 About this manual..... 5**
 - 1.1 Signal words.....5
 - 1.2 Safety symbols.....5
 - 1.3 Structure of safety instructions.....6
 - 1.4 Information symbols.....6
 - 1.5 Cross references.....7
- 2 Safety..... 8**
 - 2.1 Product conformity.....8
 - 2.1.1 European Union (EU).....8
 - 2.1.2 United Kingdom (GB).....8
 - 2.2 Dangers.....8
 - 2.3 Personnel.....8
 - 2.4 Intended use.....8
 - 2.5 Reasonably foreseeable misuse.....9
 - 2.6 Guarantee and liability.....9
 - 2.7 General safety instructions.....10
 - 2.8 Safety signs.....11
- 3 Description of the servo actuator..... 12**
 - 3.1 Overview of servo actuator components.....12
 - 3.2 Name plate.....12
 - 3.3 Ordering code.....14
 - 3.4 Performance data.....15
 - 3.5 Weight.....15
 - 3.6 Information about the lubricant.....16
- 4 Transport and storage.....17**
 - 4.1 Scope of delivery.....17
 - 4.2 Packaging.....17
 - 4.3 Transport.....17
 - 4.3.1 Transport of servo actuators up to and including size 3.....17
 - 4.4 Storage.....17
- 5 Assembly..... 18**
 - 5.1 Preparations.....18
 - 5.2 Mounting the servo actuator to a machine.....18
 - 5.3 Components mounted to the output side.....20
 - 5.4 Installing the electrical connections.....21
- 6 Startup and operation..... 22**
 - 6.1 Safety information and environmental conditions.....22
 - 6.1.1 Vibration.....22
 - 6.2 Cleaning agents and cleaning process.....22
 - 6.2.1 Recommended cleaning agents.....23
 - 6.2.2 Cleaning schedule.....23

6.3	Data for the electrical startup.....	24
7	Maintenance and disposal.....	25
7.1	Maintenance work.....	25
7.1.1	Refreshment of holding brake.....	25
7.1.2	Visual inspection.....	25
7.1.3	Checking the tightening torques.....	26
7.2	Startup after maintenance work.....	26
7.3	Maintenance schedule.....	26
7.4	Disposal.....	26
8	Malfunctions.....	27
9	Appendix.....	29
9.1	Specifications for mounting to a machine.....	29
9.1.1	Specifications for mounting with threaded holes.....	29
9.2	Tightening torques for common thread sizes in general mechanical engineering.....	29
9.3	Tightening torques for common thread sizes with corrosion-resistant screw connections.....	30
9.4	Technical data.....	30
9.4.1	Technical data of the resolver.....	30
9.4.2	Technical data of the HIPERFACE® absolute encoder (Singleturn).....	31
9.4.3	Technical data of the HIPERFACE® absolute encoder (Multiturn).....	31
9.4.4	Technical data of the HIPERFACE DSL® absolute encoder (Singleturn).....	31
9.4.5	Technical data of the HIPERFACE DSL® absolute encoder (Multiturn).....	32
9.4.6	Technical data of the EnDat 2.1 absolute encoder (Singleturn).....	32
9.4.7	Technical data of the EnDat 2.1 absolute encoder (Multiturn).....	33
9.4.8	Technical data of the EnDat 2.2 absolute encoder (Singleturn).....	33
9.4.9	Technical data of the EnDat 2.2 absolute encoder (Multiturn).....	33
9.4.10	Technical data of the HIPERFACE® absolute encoder (Singleturn) (compatible with Rockwell).....	34
9.4.11	Technical data of the HIPERFACE® absolute encoder (Multiturn) (compatible with Rockwell).....	34
9.4.12	Technical data of the HIPERFACE DSL® absolute encoder (Singleturn) (compatible with Rockwell).....	34
9.4.13	Technical data of the HIPERFACE DSL® absolute encoder (Multiturn) (compatible with Rockwell).....	35
9.4.14	Technical data of temperature sensor PTC.....	35
9.4.15	Technical data of temperature sensors KTY and PT 1000.....	35
9.4.16	Technical data of the brake.....	36
9.4.17	Connection cables and cable allocation.....	37
9.4.18	Current carrying capacity of cables.....	43
9.4.19	Direction of rotation.....	44

1 About this manual

This manual contains information which is necessary for the safe use of the servo actuator.

If this manual is supplied with any amendments (e.g. for special applications), the information in the amendments is primarily and exclusively valid.

If you have any questions about special applications, please contact **WITTENSTEIN alpha GmbH**.

WITTENSTEIN alpha GmbH provides this manual for all production sites worldwide. The manufacturer of the product is indicated on the name plate (see chapter [3.2 Name plate](#)).

The operator must ensure that this operating manual is read and fully understood by all persons assigned to install, operate, or maintain the servo actuator.

Store the manual within reach of the servo actuator.

Inform colleagues who work in the area around the machine about the **safety instructions and warnings** so that no one sustains injuries.

The original was prepared in German, all other language versions are translations of the original instructions.

1.1 Signal words

The following signal words are used to indicate hazards, things that are forbidden and important information:

▲ DANGER



This signal word indicates an impending danger that could result in severe injuries or even death.

- A "prompt to action" indicates how the danger can be avoided.

▲ WARNING



This signal word indicates a potential danger that could result in severe injuries or even death.

- A "prompt to action" indicates how the danger can be avoided.

▲ CAUTION



This signal word indicates a potential danger that could result in minor to severe injuries.

- A "prompt to action" indicates how the danger can be avoided.

NOTICE

This signal word indicates a potential danger that could result in material damage.

- A "prompt to action" indicates how the danger can be avoided.

Important

A note without a signal word indicates tips for application or especially important information for handling the servo actuator.

1.2 Safety symbols

The following safety symbols are used to indicate hazards, things that are forbidden and important information:



General danger



Hot surface



Suspended loads



Entanglement



Electric voltage



Flammable



Environmental protection



Information



Electrostatically sensitive device

1.3 Structure of safety instructions

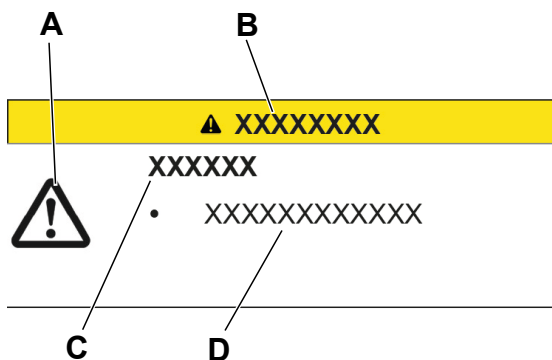

Safety information in this manual has been structured according to the following template:

A = Safety symbol (see chapter 1.2 Safety symbols)

B = Signal word (see chapter 1.1 Signal words)

C = Type and consequence of the danger

D = Avoiding the danger

1.4 Information symbols

The following information symbols are used:

1. Indicates an action to be performed

ⓘ Provides additional handling information

→ Indicates the results of an action

1.5 Cross references

A cross reference refers to the chapter number and the header of the target section (e.g. [2.4 Intended use](#)).

A cross reference to a table refers to the table number (e.g. Table [Tab. 10](#)).

2 Safety

These instructions, especially the safety and warning notices and the rules and regulations valid for the operating site, must be observed by all persons working with the servo actuator.

In addition to the safety-related information in this manual, also observe any legal and otherwise applicable rules and regulations, particularly for accident prevention (e.g. personal safety equipment) and environmental protection.

2.1 Product conformity

2.1.1 European Union (EU)

2.1.1.1 Machine safety

The servo actuator is within the scope of the Machinery Directive 2006/42/EC. According to the Machinery Directive, the servo actuator is classified as partly completed machinery. For this reason, it does not bear a CE mark with reference to the Machinery Directive.

The partly completed machinery must not be put into operation before it is verified that the machinery in which the partly completed machinery is to be incorporated complies with the regulations of the Machinery Directive.

2.1.2 United Kingdom (GB)

2.1.2.1 Machine safety (GB)

The servo actuator is within the scope of the regulation S.I. 2008 No. 1597, Supply of Machinery (Safety) Regulations 2008. According to the Supply of Machinery (Safety) Regulation, the servo actuator is classified as partly completed machinery. For this reason, it does not bear a UKCA mark with reference to the Supply of Machinery (Safety) Regulation.

The partly completed machinery must not be put into operation before it is verified that the machinery in which the partly completed machinery is to be incorporated complies with the regulations of the Supply of Machinery (Safety) Regulation.

2.2 Dangers

The servo actuator has been constructed according to current technological standards and accepted safety regulations.

To avoid danger to the operator or damage to the machine, the servo actuator may be put to use only for its intended use (see chapter [2.4 Intended use](#)) and in a technically flawless and safe state.

1. Read the general safety instructions before starting any work (see chapter [2.7 General safety instructions](#)).

2.3 Personnel

Only technicians who have read and understood this operating manual may perform work on the servo actuator. Based on their training and experience, technicians must be able to evaluate the tasks assigned to them in order to recognize and avoid risks.

2.4 Intended use

The servo actuator is designed to be installed in or connected to the following machines, incomplete machines, or equipment:

- stationary large-scale plants,
- stationary industrial tools,
- Movable machines, not intended for road use and only provided for professional (industrial) use.

In particular the following points must be observed:

- The servo actuator must be controlled by a servo controller.

- The servo actuator must not be used in applications with special environmental conditions e.g. vacuum, potentially explosive atmospheres, clean room or areas with radioactive contamination.
- Servo actuators of the axenia series comply with the Hygienic Design.
 - The servo actuator may therefore also be used over the product area in food processing / pharmaceutical / cosmetics applications.
 - The cables may only be placed outside the product area. Parts of the product (e.g. food) that come into contact with a cable must not be used in the product.
 - Observe the instructions in chapter [3.6 Information about the lubricant](#).
- Safety equipment required for a risk-free operation must be present, properly installed, and fully functional. It must not be removed, changed, bypassed, or rendered ineffective.
- In case of an emergency shutdown, power failure, and/or damage to the electrical equipment, the servo actuator must be
 - switched off immediately,
 - secured against uncontrolled re-activation,
 - secured against uncontrolled after-running.
- The optionally installed brake is simply a holding brake and may be utilized only in emergency stop situations for braking the running servo actuator.

2.5 Reasonably foreseeable misuse

Any use that deviates from the approved technical data (e.g. speed, force, torque, temperature) is not use as intended and is therefore not permitted. In particular the following applications are not permitted:

- Operation of the servo actuator, without properly installing it in or connecting it to other machines or other partly completed machines or equipment.
- Operation of the servo actuators in a defective state
- Operation of the servo actuator, without determining that the machine in which it is to be installed complies with the provisions of the Machinery Directive 2006/42/EC.
- Operation of the servo actuator in a potentially explosive environment
- Assembly of the servo actuator without prior reading of the operating/installation instructions
- Operation of the servo actuator without legible warning and information signs
- Use of improper lubricants
- Use of unsuitable servo drives
- Use in improper installation, operating, performance, and ambient conditions
- Assembly of the servo actuator by insufficiently competent personnel

2.6 Guarantee and liability

Guarantee and liability claims are excluded for personal injury or material damage in case of

- Ignoring the information on transport and storage
- Improper use (misuse)
- Improper or not carried out maintenance and repair
- Improper assembly/disassembly or improper operation (e.g. test run without secure attachment)
- Operation of the servo actuator when safety devices and equipment are defective
- Operation of the servo actuator without lubricant
- Operation of a heavily soiled servo actuator

- Modifications that have been carried out without written authorization from **WITTENSTEIN alpha GmbH**

2.7 General safety instructions

⚠ DANGER



Faulty electrical connections or unapproved, current-carrying components can cause serious injuries and even death:

- Have all electrical connection work performed by qualified technicians only.
- Immediately replace damaged cables or plugs.

⚠ WARNING



During generator operation, voltage is induced. This can cause lethal current surges.

- Ensure that no plugs and connections are exposed during generator operation.

⚠ WARNING



Objects flung out by rotating components can cause serious injuries.

- Remove objects and tools from the servo actuator before putting it into operation.

⚠ WARNING



Rotating components on the servo actuator can pull in parts of the body and cause serious injuries and even death.

- Keep a sufficient distance to rotating machinery while the servo actuator is running.
- Secure the machine against restarting and unintentional movements during assembly and maintenance work (e.g. uncontrolled lowering of lifting axes).

⚠ WARNING



A wrong direction of rotation or direction of movement may result in serious injury or death. The direction of rotation or movement may differ from the standard IEC 60034–8.

- Before and during startup, ensure that the servo actuator has the correct direction of rotation or movement (see chapter [9.4.19 Direction of rotation](#)).
- Be sure to avoid collision (caused e.g. by crashing against an end stop).
- With the danger area secured, check the direction of rotation or movement at a slow speed, ideally by limiting the current and torque.

⚠ WARNING



A damaged servo actuator can cause accidents with the risk of injury.

- Never operate a servo actuator that has been overloaded due to misuse or a machine crash (see chapter [2.5 Reasonably foreseeable misuse](#)).
- Replace the affected servo actuators, even if no external damage is visible.

⚠ CAUTION

Hot servo actuator housing (up to 125 °C) can cause serious burns.

- Touch the servo actuator housing only when wearing protective gloves or after the servo actuator has been idle for some time.

NOTICE

Loose or overloaded screw connections can damage the servo actuator.

- Use a calibrated torque wrench to tighten and check all screw connections for which tightening torques have been specified.

⚠ WARNING

Lubricants are flammable.

- Do not use a jet of water to extinguish.
- Suitable extinguishing agents are powder, foam, water mist and carbon dioxide.
- Observe the safety instructions of the lubricant manufacturer (see chapter [3.6 Information about the lubricant](#)).

⚠ CAUTION

Solvents and lubricants can cause skin irritations.

- Avoid direct skin contact.

NOTICE

Solvents and lubricants can pollute soil and water.

- Use and dispose of cleaning solvents and lubricants properly.

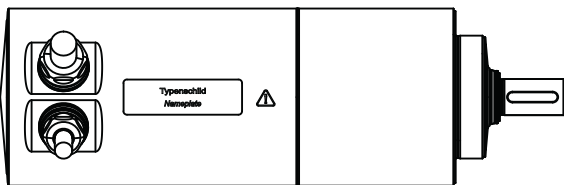
2.8 Safety signs

There is a laser-etched safety sign on the servo actuator housing that warns against hot surfaces.

Tip

Make sure that the name plate is legible.

3 Description of the servo actuator

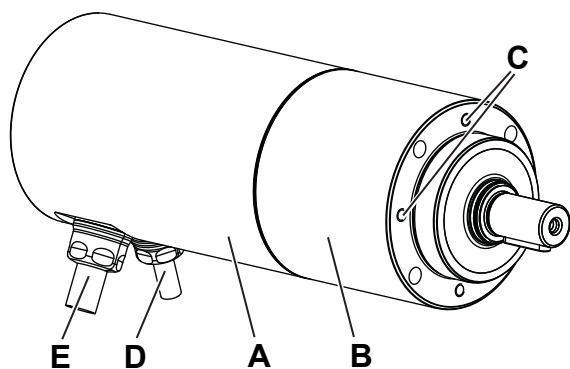

The servo actuator complies with the **Hygienic Design**. The servo actuator may therefore also be used over the product area in food processing / pharmaceutical / cosmetics applications. The cables may only be placed outside the product area.

The servo actuator is a combination of a low-backlash planetary gearbox (B) and an AC servomotor (A). The servo actuator may be used only in a defined mounting position.

It is mounted on the machine by means of drive-side threaded holes (C).

The cables (D, E) are connected ex works. The cables are selected in the ordering process.

The servo actuator can be cleaned easily and is corrosion-resistant.

3.1 Overview of servo actuator components

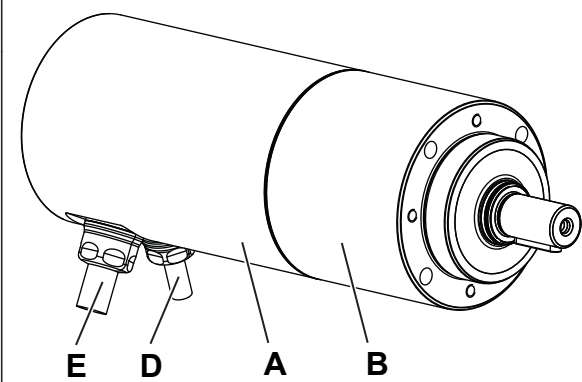
		Servo actuator components
	A	AC servo motor
	B	Planetary gearbox
	D	Motor feedback connection
	E	Power connection

Tab. 1: Servo actuator components

3.2 Name plate

The name plate is laser-etched onto the servo actuator housing.

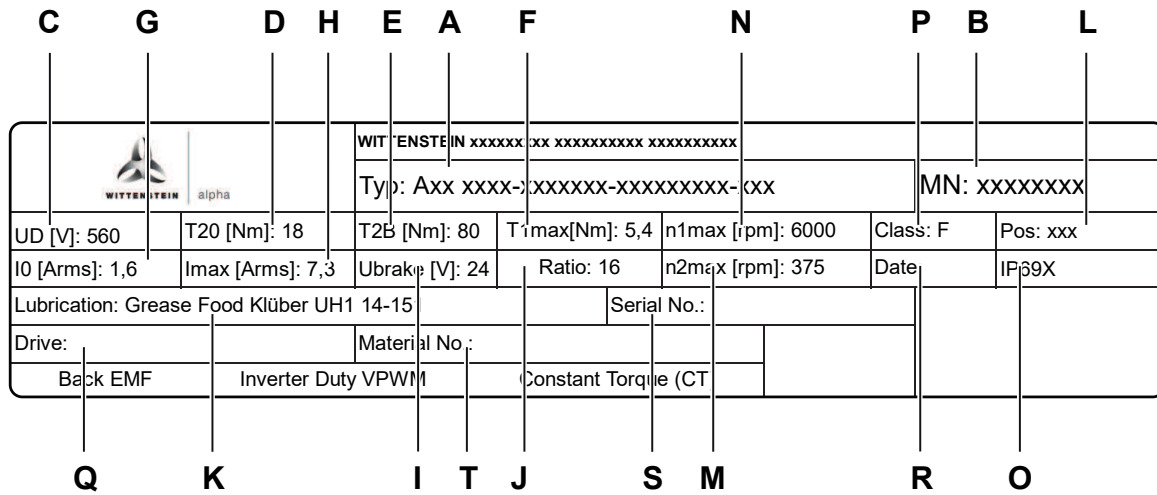

	Designation		Designation
A	Ordering code; see chapter 3.3 Ordering code)	K	Lubrication
B	Material number	L	Mounting position
C	Intermediate circuit voltage	M	max. speed
D	Continuous stall torque at gear output	N	Max. speed of the motor
E	max. acceleration torque at output	O	Protection class
F	Max. motor acceleration torque	P	Insulation class
G	Continuous stall current of the motor	Q	Servo converter
H	max. motor acceleration current	R	Production date
I	Brake voltage	S	Serial number
J	Gear ratio	T	Customer material number (optional)

Tab. 2: Name plate (sample values)

3.3 Ordering code

Servo actuator ordering code

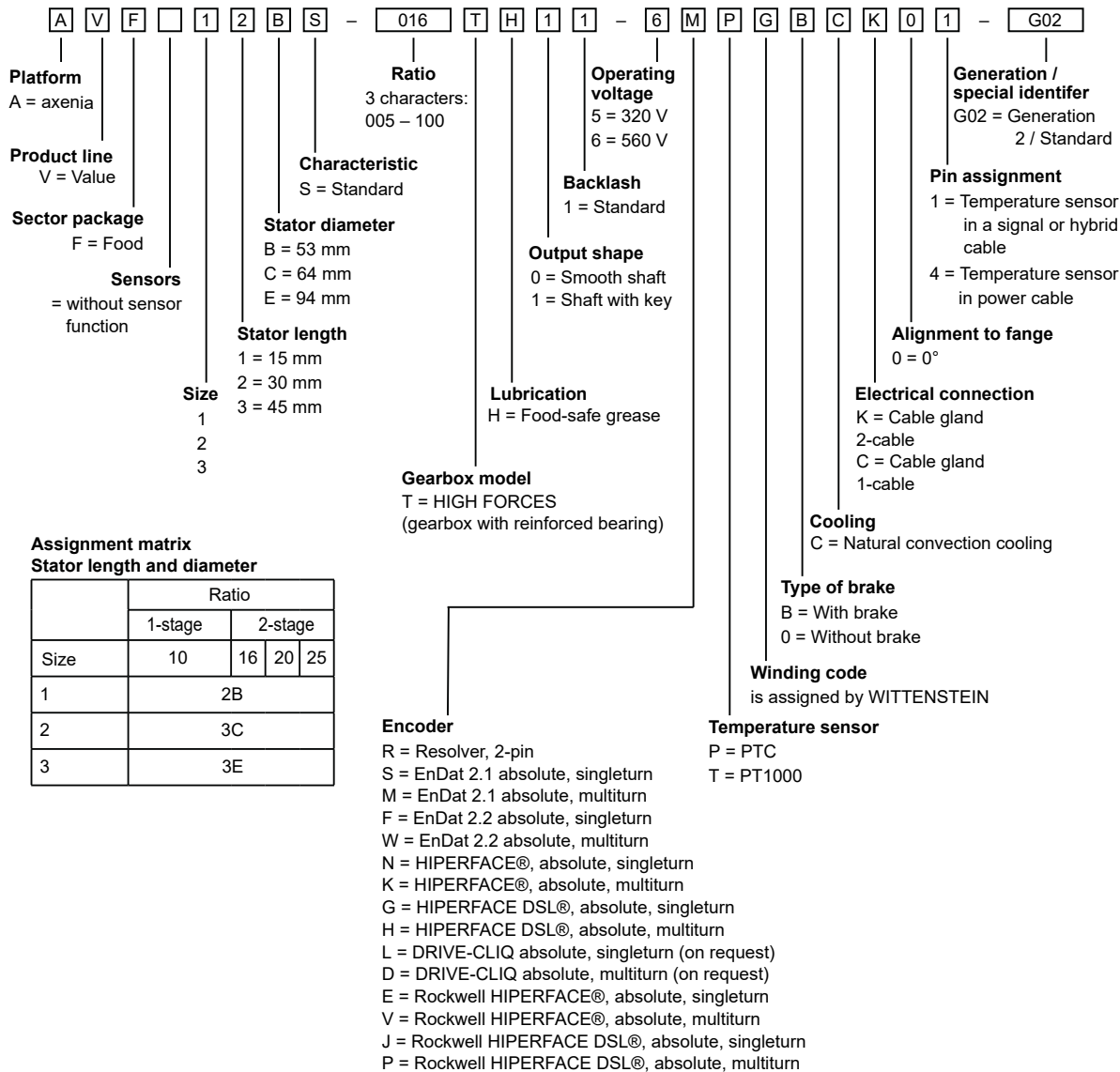

Cable ordering codes

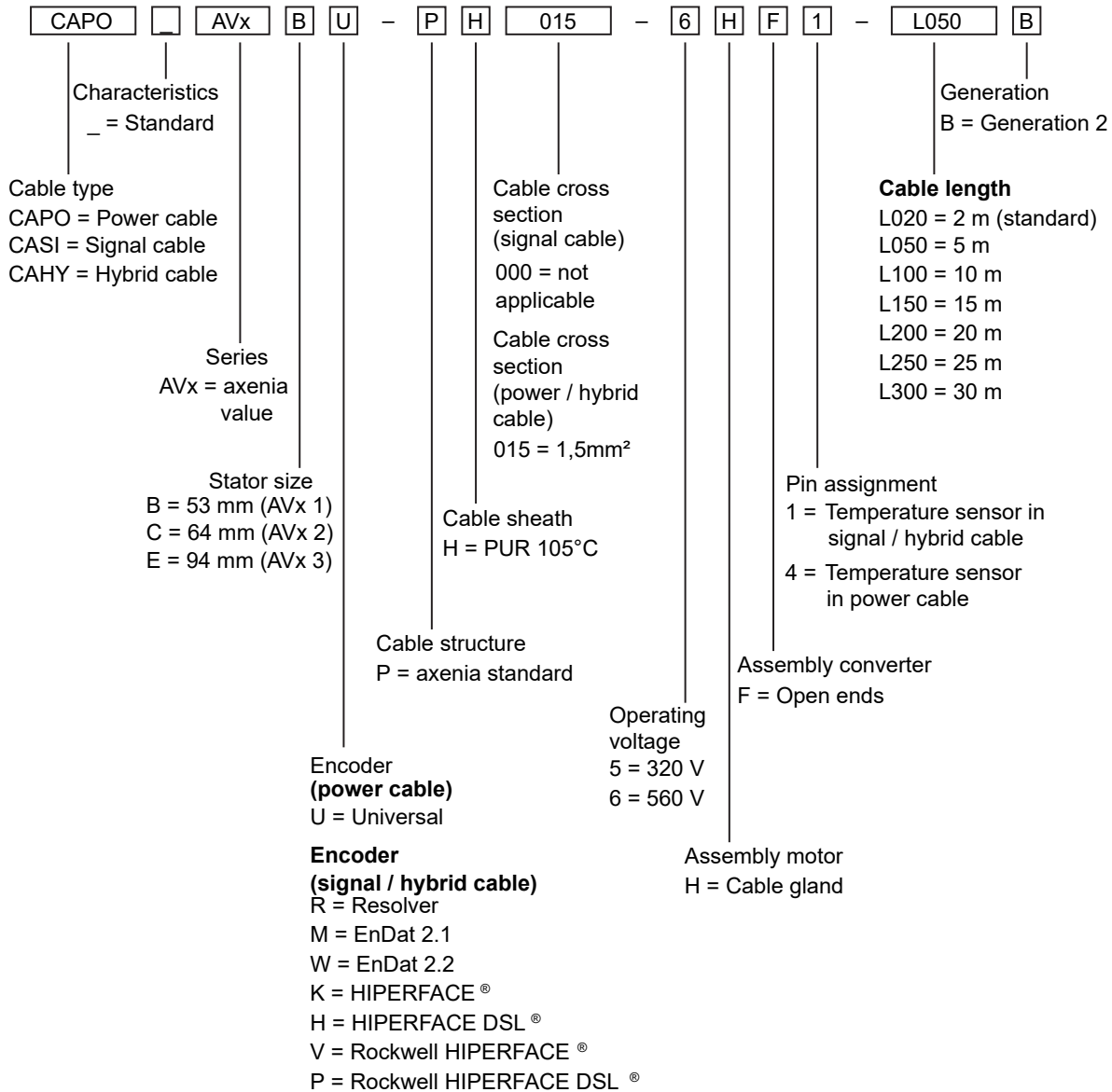

3.4 Performance data

For the maximum permitted speeds and torques, refer to the product-specific data sheet.

Tip

For additional information, please contact our sales department. Always state the serial number when doing so.

3.5 Weight

The standard weights of the servo actuators (with resolver, without cable) are specified in the table. Depending on the version, the actual weight can deviate by up to 20 %. The weights of the cables must be taken into account separately.

Tip

For further information on the cables, please refer to chapter [9.4.17 Connection cables and cable allocation](#).

Size of axenia value	AVF 1		AVF 2		AVF 3	
	1-stage	2-stage	1-stage	2-stage	1-stage	2-stage
without brake [kg]	5.5	6.1	9.8	11.0	21.0	24.1
with brake [kg]	5.6	6.2	9.9	11.1	21.3	24.4

Tab. 3: Weight of axenia

3.6 Information about the lubricant

Important

The servo actuator is lubricated ex works for the entire working life with synthetic lubricant according to NSF H1 approved for the food sector (see name plate).

All bearings are permanently lubricated by the manufacturer.

4 Transport and storage

4.1 Scope of delivery

1. Check the completeness of the delivery against the delivery note.

 Missing parts or damage must be reported immediately in writing to the carrier, the insurance, or **WITTENSTEIN alpha GmbH**.

4.2 Packaging

The servo actuator is delivered packed in foil and cardboard boxes.

1. Dispose of the packaging materials at the recycling sites intended for this purpose. Please observe the valid national regulations for waste disposal.

4.3 Transport

▲ WARNING



Suspended loads can fall and can cause serious injuries and even death.

- Do not stand under suspended loads.
- Secure the servo actuator with suitable fasteners (e.g. belts) before transport.

NOTICE



Hard knocks, e.g. due to falling or hard dropping, can damage the servo actuator.

- Only use hoisting equipment and lifting accessories with sufficient capacity.
- Never exceed the maximum permissible load for hoisting equipment.
- Lower the servo actuator slowly.

NOTICE



Improper lifting can damage the cable glands on the servo actuator.

- Never lift the servo actuator by the cable.

For specifications on the weights, refer to chapter [3.5 Weight](#).

Ambient temperatures between -20 °C and +50 °C are permissible for transport only.

4.3.1 Transport of servo actuators up to and including size 3

No special mode of transport is prescribed for transporting the servo actuator.

Lifting by the electrical connections or the output shaft / output flange is not permitted.

4.4 Storage

Store the servo actuator in horizontal position and dry surroundings at a temperature of 0 °C to +40 °C in the original packaging. Store the servo actuator for a maximum of 2 years. Consult our Customer Service department if conditions are different.

For storage logistics, we recommend the "first in – first out" method.

5 Assembly

1. Read the general safety instructions before starting any work (see chapter [2.7 General safety instructions](#)).

2.

NOTICE

Only a sealed mounting guarantees the fault-free functioning of the servo actuator.

- Seal potential gaps when mounting on the machine and when mounting on the output side.

Tip

WITTENSTEIN alpha GmbH provides suitable mounting kits for this (see chapter [5.2 Mounting the servo actuator to a machine](#))

Note the special information on mounting (chapter [5.2 Mounting the servo actuator to a machine](#)).

5.1 Preparations

The screws for mounting are not included in the scope of delivery and must be provided by the customer. Information can be found in the individual assembly steps.

NOTICE

Many electronic components are sensitive to electrostatic discharge (ESD). This particularly concerns integrated circuits (IC), semiconductors, resistors with a tolerance of no more than one percent as well as transistors and other components such as encoders.

- Observe the directives concerning ESD protection.

NOTICE

Compressed air can damage the servo actuator seals.

- Do not use compressed air to clean the servo actuator.

1. Clean/de-grease the output shaft, centering and fitting surface of the servo actuator with a clean, lint-free cloth moistened with a suitable grease-dissolving but non-aggressive cleaning agent.
2. Dry all fitting surfaces to neighboring components to achieve the proper friction values for the screw connections.
3. In addition, check the fitting surfaces for damage and impurities.
4. Check whether all corrosion protection was removed from all extern components without any residues.
5. Only use a tool that is suitable for working with stainless steel.

5.2 Mounting the servo actuator to a machine

Important

The servo actuator is suitable for the following mounting position. The type of lubricant filled into the servo actuator is indicated on the name plate (see chapter [3.2 Name plate](#)).

Mount the servo actuator only in the specified mounting position.

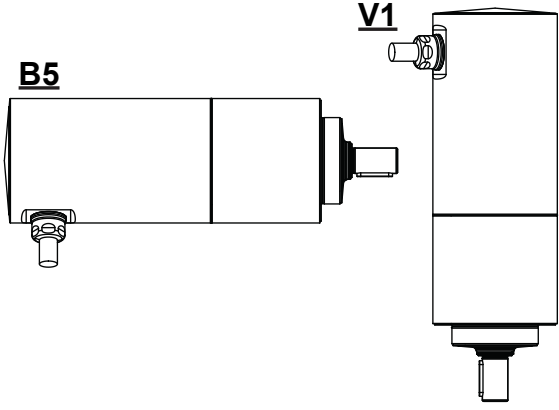
	Mounting position	Description
	B5	Horizontal output shaft (with cable outlet downward)
	V1	Output shaft downward

Tab. 4: Permitted mounting positions

Important

Observe the safety and processing instructions for the threadlocker to be used.

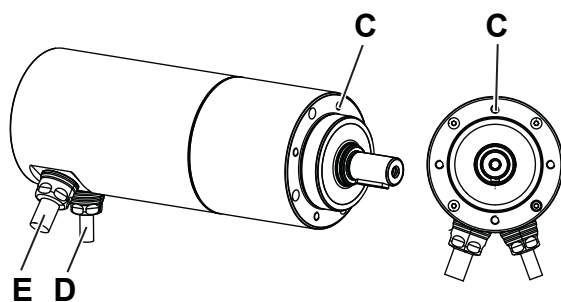

The servo actuator housing has threaded holes (C) for bolting the gearbox to a machine.

1. Thoroughly clean the output shaft, centering and fitting surface.

The screws must be provided by the customer. The screws should preferably have hygienically designed surfaces in order to be easily cleanable. **WITTENSTEIN alpha GmbH** provides corresponding mounting kits for this (see table [Tab. 5](#)). The prescribed screw sizes and tightening torques can be found in chapter [9.1 Specifications for mounting to a machine](#)

2. Coat the fastening screws with a threadlocker (e.g. Loctite® 243).
3. Fasten the servo actuator to the machine with the fastening screws using the threaded holes (C).

Note that the surface of the machine exhibits little roughness. This makes cleaning easier.

Do not use any washers (e.g. plain washers, tooth-lock washers).

Install the servo actuator on the machine in a way which ensures the accessibility of all sides during cleaning. Difficult to reach areas can negatively affect both the cleaning result and its assessment.

Install the servo actuator so that the connections (D, E) face downward. Avoiding horizontal surfaces assists with the automatic removal of media during cleaning.

Use the screw head seals and O-rings for sealing.

WITTENSTEIN alpha GmbH offers corresponding mounting kits for this. The separate instructions "Hygienic Design Instruction Sheet, Mounting Kit" (Doc. no. 2022–D062618) are valid for this. The manual will be provided by our Sales / Customer Service department on request. Always state the serial number when doing so.

The following mounting kits are available:

Size of axenia value	AVF 1	AVF 2	AVF 3
Mounting kit material number	20058220	20058222	20058221

Tab. 5: Mounting kit

The mounting kits contain the following single parts:

	Designation	
	S ₁	Screw head seal
	S	Screw (machine mounting)
	Q _{4c}	Disc (output mounting)
	T ₁	Screw head seals
	T	Screw (output mounting)
	E	Gearbox
	U	Machine (mountable flange for gearbox)
	E _{1a}	O-ring
	E _{1b}	O-ring
	P ₁	Mounting part, output side (e.g. toothed wheel)
	Q _{4a}	O-ring
	Q _{4b}	O-ring

Tab. 6: Single parts in the mounting kit

Use the screw head seals [S₁] as well as O-rings [E_{1a}, E_{1b}] for sealing.

Observe the incorporation of contoured sealing surfaces on the attachment parts so that O-rings are firmly fitted.

5.3 Components mounted to the output side

NOTICE

Distortions during mounting operations can damage the servo actuator.

- Mount the mounting parts onto the output shaft without using force.
- Do **not** attempt to assemble by force or hammering!
- Only use suitable tools and devices for assembly.
- Make sure not to exceed the maximum permissible static axial forces on the output bearing (see table Tab. 7:) when pulling or shrink-fitting a toothed wheel onto the output shaft.

Size of axenia value	AVF 1	AVF 2	AVF 3
$F_{a \max}$ [N]	1000	1500	3000

Tab. 7: Maximum permissible static axial forces at static load rating (s_0) = 1.8 and radial force (F_r) = 0

1. Seal potential gaps when mounting on the output side.

Ensure that the surface of the mounting parts exhibits little roughness. This makes cleaning easier.

Use the screw head seals and O-rings for sealing.

WITTENSTEIN alpha GmbH provides suitable mounting kits for this (see chapter [5.2 Mounting the servo actuator to a machine](#), p. 18)

5.4 Installing the electrical connections

⚠ DANGER



Electrically live parts may result in electric shocks if touched and can cause serious injuries and even death.

- Observe the five safety rules of electrical engineering before starting electrical installation work:
 - Disconnect from the main power supply
 - Secure against being switched on again
 - Ensure that the machine is de-energized
 - Ground and short circuit
 - Cover any live parts in the immediate vicinity
- Check whether there are protective caps on the plugs. If protective caps are missing, check the plugs for damage and soiling.

⚠ DANGER



Electrical work performed in damp areas may result in electric shocks and can cause serious injuries and even death.

- Carry out the electrical assembly only in dry areas.

Important

The cables of all servo actuators need to be laid out in such a way that a minimum bending radius is observed:

- Fixed application: 7.5 x diameter.
- Moving application: 15 x diameter.

Torsional load of the cables should be avoided.

6 Startup and operation

6.1 Safety information and environmental conditions

1. Read the general safety instructions before starting any work (see chapter [2.7 General safety instructions](#)).

Wearing hearing protection in the vicinity of the servo actuator is recommended.

Improper use can damage the servo actuator.

2. Make sure that
 - the **ambient temperature** does not drop below -18 °C or exceed $+40\text{ °C}$ and
 - the **operating temperature** does not exceed $+90\text{ °C}$
3. Avoid icing, which can damage the seals.
4. Only operate the servo actuator when it is firmly mounted and in the permissible mounting positions, see chapter [5.2 Mounting the servo actuator to a machine](#).
5. Use the servo actuator only up to its maximum limit values, see the product-specific data sheet.
6. Make sure that the servo actuator is used in accordance with the requirements in chapter [2.4 Intended use](#).
7. Note the special information on cleaning (chapter [6.2 Cleaning agents and cleaning process](#)).

6.1.1 Vibration

Based on vibrations at a stationary place of use, limit values apply according to DIN EN 60721-3-3:1995 and DIN EN 60068-2-6:2007.

Maximum permissible vibration load (55-2000 Hz)
10 m/s ²

Tab. 8: Limit value for vibration load

A higher vibration load may be permissible in specific cases. For additional information, please contact our Sales/Customer Service department.

6.2 Cleaning agents and cleaning process

The pump effect of a running servo actuator can suck cleaning agents into the servo actuator. The servo actuator may only be cleaned when it is installed and at a standstill.

1. Clean the servo actuator only when there is no voltage present.

Aggressive cleaning agents might cause corrosion.

2. Use only the cleaning agents listed in chapter [6.2.1 Recommended cleaning agents](#).

Pressurized air can damage the seals of the servo actuator and thus lead to leakage.

3. Use a water jet with a **maximum** pressure of 28 bar.

A roughened surface cannot be cleaned without leaving residues.

4. Take care not to scratch the servo actuator. For cleaning, do not use scouring agent, sponges or wire mesh which directly affect the surface.

Additionally, observe the following instructions for cleaning:

5. Remove applied media from the sealing of the servo actuator within 30 minutes.
6. Clean the servo actuator with a maximum water temperature of 80 °C .
7. Thoroughly clean the servo actuator over its entire circumference, i.e. everywhere.
8. Use only cleaning processes as described in chapter [6.2.2 Cleaning schedule](#).

6.2.1 Recommended cleaning agents

The following cleaning agents from ECOLAB Deutschland GmbH (www.ecolab.eu) were laboratory-tested for servo actuator cleaning with regard to surface resistance and sealing materials.

- Topactive 200 (alkaline foam cleaner), 5% in demineralized water
- Topactive 500 (acidic foam cleaner), 5% in demineralized water
- P3-topax 66 (chlorine-alkaline foam disinfectant), 5% in demineralized water
- P3-topax 990 (mildly alkaline disinfectant cleaner), 3% in demineralized water
- P3-topactive OKTO (foam disinfectant peracid), 1% in demineralized water

To check the resistance, test samples were placed for 28 days in the indicated test concentration of the respective cleaning agent without mechanical influence in accordance with the Ecolab test method F&E/P3-E no. 40-1 / 09.2014 rev. 4.

6.2.2 Cleaning schedule

Important

The servo actuator may only be cleaned when it is in the installed state.

Observe the specifications in chapters [2.4 Intended use](#) and [5.2 Mounting the servo actuator to a machine](#).

Tip

We recommend the use of a mounting kit. Our Customer Service department is available to answer any questions.

NOTICE

Reaching the indicated possible service life cannot be guaranteed if the recommended cleaning agents, reaction times and concentrations are not adhered to.

- Use only cleaning agents and cleaning process as described in this manual.
 - Carefully observe the technical specification sheets and safety instructions of the cleaning agent manufacturer.
-

The cleaning procedure is to follow the following cleaning schedule in accordance to the recommendations of ECOLAB GmbH:

Preparation and pre-rinse at a temperature of approx. 50 °C

1. Remove coarse processing residues.
2. Rinse the servo actuator at low pressure and with the spray jet pointing downwards, and remove the rinsed-off residues.

Foam cleaning and intermediate rinsing

3. Foam all surfaces thoroughly using a foam cleaner specified in chapter [6.2.1 Recommended cleaning agents](#) in a 2-5% solution.

A reaction time of 15 minutes is recommended.

4. Then perform an intermediate rinsing with warm water up to 50 °C.
5. Check the cleaning results, especially at critical points.

Disinfection and rinsing

6. After every cleaning, perform a neutral disinfection using a foam disinfectant/disinfectant cleaner listed in chapter [6.2.1 Recommended cleaning agents](#) in a 1-2% solution. Pay special attention to ensure that the surfaces to be cleaned are completely wetted.

Reaction time 15-30 minutes (depending on degree of contamination).

7. Rinse the servo actuator from top to bottom with water (drinking water quality).

→ We recommend a subsequent swab or adhesive film test for a microbiological surface analysis.

6.3 Data for the electrical startup

Data for electrical startup can be found in the product-specific data sheet.

Tip

For additional information, please contact our sales department. Always state the serial number when doing so.

NOTICE

The servo controllers of the different manufacturers generally have proprietary data specifications.

If the data is disregarded, the drive and/or the servo controller may be damaged.

- Observe the listed units **precisely** and check their conformance with the units of the servo controller.
 - If the units differ, adjust accordingly.
-

Tip

In some servo controllers, there are dependencies between individual parameters. We will gladly help you to find the correct entries.

Tip

We provide adjusted and certified Quick Start Guides for several servo controllers.

Tip

For further information, visit our website at www.wittenstein-alpha.de or contact our support for startup: wcm-support@wittenstein.de

7 Maintenance and disposal

1. Read the general safety instructions before starting any work (see chapter [2.7 General safety instructions](#)).

▲ WARNING



The permanent magnets of the stator send a strong magnetic field, which becomes active during the disassembling of the servo actuator.

- Observe the general safety instructions (e.g. for pacemaker patients) for working in strong magnetic fields.

7.1 Maintenance work

Important

The partial or complete disassembly of the servo actuator into its individual parts for maintenance or repair work is not permitted.

In case of a malfunction or failure, please contact the Customer Service department.

7.1.1 Refreshment of holding brake

The holding torques of the holding brakes used in the servo actuators are influenced by various factors, e.g. oxidation of abraded particles, flattening of friction surfaces due to frequent application of the brakes in the same position or air gap changes due to wear. This can lead to a tolerance in the holding torque of - 50% to + 100%.

The specified holding torques apply under optimal conditions, without damaging influences. The deterioration of the holding torque can be reduced by refreshing the brakes periodically.

For critical applications we recommend dimensioning for an adequately large holding torque to take account of these factors. Our in-house engineering department will be pleased so assist you with the relevant dimensioning.

A maintenance interval of 4 weeks is recommended for common industrial applications.

For your dimensioning, observe the effective torques during running-in.

Recommended brake refreshment cycle				
Ordering code: AVF xxxx-xxxxxxx-xxxxBxxxx-xxx				
	Unit	AVF 1	AVF 2	AVF 3
Slipping speed	min ⁻¹	200	200	100
Duration, brake de-energized	sec	0.5		
Duration, brake energized	sec	0.5		
Number of cycles	–	5		

Tab. 9: Recommended brake refreshment cycle: axenia value

7.1.2 Visual inspection

1. Check the entire servo actuator and all cables for exterior damage.
2. Seals are subject to wear. Therefore, also check the servo actuator for leakage during each visual inspection (lubricant leaks), particularly at the gearbox.

Check in the mounting position that no foreign medium (e.g. oil) has collected on the output shaft.

3. Also check the entire servo actuator for corrosion.

4. Check whether the name plate is present and legible (see chapter [3.2 Name plate](#)).

For specific information on maintenance-related issues, contact our Customer Service department.

7.1.3 Checking the tightening torques

Screw connections between servo actuators and attached components must be calculated, dimensioned, mounted, and tested according to current technological standards. Use the VDI directives VDI 2862 sheet 2 and VDI 2230 for example.

Tip

The tightening torques recommended by us can be found in chapter [9 Appendix](#).

7.2 Startup after maintenance work

1. Clean the outside of the servo actuator.
2. Attach all safety devices.
3. Perform a trial run before releasing the servo actuator again for operation.

7.3 Maintenance schedule

Maintenance work	At startup	For the first time after 500 operating hours or 3 months	Every 4 weeks	Every 3 months
7.1.1 Refreshment of holding brake			X	
7.1.2 Visual inspection	X	X		X
7.1.3 Checking the tightening torques	X			

Tab. 10: Maintenance schedule

7.4 Disposal

Consult our Customer Service department for more information on disassembly and disposal of the servo actuator.

1. Dispose of the servo actuator at the recycling sites intended for this purpose.

Please observe the valid national regulations for waste disposal.

8 Malfunctions

NOTICE

Changed operational behavior can be an indication of existing damage to the servo actuator, or cause damage to the servo actuator.

- Do not put the servo actuator back into operation until the cause of the malfunction has been rectified.

Important

Malfunctions may only be rectified by specially trained technicians.

To facilitate troubleshooting and the optimization of servo drive settings, it is useful to record the current over a full cycle (a servo drive function) and make it available as a file.

Error	Possible cause	Solution
Acceleration times are not met	Load is too high	Check sizing
	Power limiting active	Check the servo drive parameters
Brake does not release	Voltage drop along the feed line > 10%	Ensure that the supply voltage is correct. Check the cable cross-section.
	Incorrect brake connection	Check the connection for correct polarity and voltage
	Short circuit in the coil or at body of brake coil	Consult our Customer Service department.
Holding brake slips	Holding torque of the brake exceeded	Check sizing.
Increased operating noises	Damaged bearings Toothing damage	Consult our Customer Service department.
Increased operating temperature	Sizing insufficient, nominal operating exceeded.	Check the technical data.
	Motor is heating the gearbox	Check the settings of the servo drive.
	Ambient temperature too high.	Ensure adequate cooling.
Loss of lubricant	Seeping	Wipe off discharged lubricant and continue to monitor the behavior of the gearbox. Lubricant discharge should stop after a short time.
	Seals not tight	Consult our Customer Service department.

Error	Possible cause	Solution
Motor does not start	Feed line interrupted	Check the connections
	Wiring of motor and/or encoder not correct	Check the wiring of the motor phases and the motor encoder
	Blown fuse	Check for faults and replace the fuse
	Incorrect servo drive parameters	Check that the motor parameters are suitable for the implemented servo actuator
	Motor protection has been triggered	Check for faults. Check whether the motor protection setting is correct.
Motor is droning and has a high power consumption	Drive is blocked	Check the drive
	Error in the encoder line	Check the encoder line
	Incorrect servo drive parameters	Check that the motor parameters are suitable for the implemented servo actuator
	Brake does not release	(see fault "Brake does not release")
Position error	Shielding of the encoder line insufficient	Check the shielding of the connection cables
	Disturbing pulse from the brake, protective circuit of the brake missing or defective	Check the protective circuit (e.g. Varistor) of the brake on the converter
	Mechanical coupling between the motor shaft and encoder defective	Consult our Customer Service department.
Wrong direction of rotation	Wrong set value specification for the servo controller	Check servo controller/ converter. Check the set value specifications and the polarities

9 Appendix

9.1 Specifications for mounting to a machine

If you have any questions about special applications, please contact **WITTENSTEIN alpha GmbH**.

9.1.1 Specifications for mounting with threaded holes

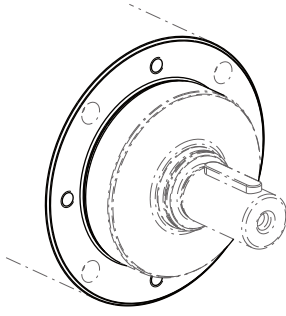
	Type/ size of axenia value	Hole circle Ø [mm]	Quantity x thread [] x [mm]	Tightening torque [Nm] Festigkeitsklasse Ax-80
	AVF 1	62	4 x M5	4.91
	AVF 2	80	4 x M6	8.42
	AVF 3	108	4 x M10	40

Tab. 11: Specifications for mounting to a machine

9.2 Tightening torques for common thread sizes in general mechanical engineering

The specified tightening torques for headless screws and nuts are calculated values and are based on the following conditions:

- Calculation according to VDI 2230 (edition 11/2015)
- Friction value for thread and contact surfaces $\mu=0.10$
- Utilization of the yield stress 90%
- Torque tools type II classes A and D in accordance with ISO 6789

The settings are values rounded to usual commercial scale gradations or settings.

Important

Use the **exact** values in this table to set your tools.

	Tightening torque [Nm] with thread												
Festigkeit- sklasse Screw / nut	M3	M4	M5	M6	M8	M10	M12	M14	M16	M18	M20	M22	M24
8.8 / 8	1.15	2.64	5.2	9.0	21.5	42.5	73.5	118	180	258	362	495	625
10.9 / 10	1.68	3.88	7.6	13.2	32.0	62.5	108	173	264	368	520	700	890
12.9 / 12	1.97	4.55	9.0	15.4	37.5	73.5	126	202	310	430	605	820	1040

Tab. 12: Tightening torques for set screws and nuts

9.3 Tightening torques for common thread sizes with corrosion-resistant screw connections

The specified tightening torques for headless screws and nuts are calculated values and are based on the following conditions:

- Calculation according to VDI 2230 (edition 11/2015)
- Friction value for thread and contact surfaces $\mu=0.10$
- Utilization of the yield stress 90%
- Only valid for:
 - Screws according to ISO 4762, ISO 4014, ISO 4017
 - Nuts according to ISO 4032, ISO 4033

The settings are values rounded to usual commercial scale gradations or settings.

Important

Use the **exact** values in this table to set your tools.

	Tightening torque [Nm] with thread												
Festigkeit- sklasse Screw / nut	M3	M4	M5	M6	M8	M10	M12	M14	M16	M18	M20	M22	M24
Ax-50	0.376	0.868	1.72	2.95	7.2	14.0	24.0	38.5	59.0	82.0	115	157	199
Ax-70	0.806	1.86	3.68	6.4	15.2	30.0	51.5	83.0	127	176	248	336	425
Ax-80	1.07	2.48	4.91	8.4	20.5	40.0	69.0	111	169	234	330	450	570

Tab. 13: Tightening torques for screws and nuts made from austenitic steel

9.4 Technical data

The technical performance data can be taken from the product-specific data sheet.

9.4.1 Technical data of the resolver

Ordering code: AVF xxxx-xxxxxxx-xRxxxxxxx-xxx	
Size	Size 15
Type	TS2620 N21 E11
No of pole pairs	1
Input voltage	7 V _{eff} 10 kHz
Transmission ratio	0.5 ±5%
Error	±10' _{max}
Zero voltage	20 mV _{eff max}
Phase shift	0° nominal
Impedance ZR0	70 + j 100 ohm
Impedance ZS0	180 + j 300 ohm

Ordering code: AVF xxxx-xxxxxxx-xRxxxxxxx-xxx	
Impedance ZSS	175 + j 257 ohm
Max. operating temperature	155 °C

Tab. 14: Technical data of the resolver

9.4.2 Technical data of the HIPERFACE[®] absolute encoder (Singleturn)

HIPERFACE [®] absolute encoder (Singleturn)	
Ordering code AVF xxxx-xxxxxxx-xNxxxxxxx-xxx	
Type	SKS36S
Operating voltage	7 - 12 V
Interface	HIPERFACE [®]
Number of SinCos periods per revolution	128
Resolution per revolution	4096 (12 bit)
Number of Multiturn revolutions	–
SIL level	SIL2

Tab. 15: Technical data of the HIPERFACE[®] absolute encoder (Singleturn)

9.4.3 Technical data of the HIPERFACE[®] absolute encoder (Multiturn)

HIPERFACE [®] absolute encoder (Multiturn)	
Ordering code AVF xxxx-xxxxxxx-xKxxxxxxx-xxx	
Type	SKM36S
Operating voltage	7 - 12 V
Interface	HIPERFACE [®]
Number of SinCos periods per revolution	128
Resolution per revolution	4096 (12 bit)
Number of Multiturn revolutions	4096 (12 bit)
SIL level	SIL2

Tab. 16: Technical data of the HIPERFACE[®] absolute encoder (Multiturn)

9.4.4 Technical data of the HIPERFACE DSL[®] absolute encoder (Singleturn)

HIPERFACE DSL [®] absolute encoder (Singleturn)	
Ordering code AVF xxxx-xxxxxxx-xGxxxxxxx-xxxPxG xxxx-xxxxxxx-xGxxxxxxx-xxx	
Type	EKS36
Operating voltage	7 - 12 V
Interface	HIPERFACE DSL [®]

HIPERFACE DSL[®] absolute encoder (Singleturn)	
Ordering code AVF xxxx-xxxxxxx-xGxxxxxxx-xxxPxG xxxx-xxxxxxx-xGxxxxxxx-xxx	
Number of SinCos periods per revolution	–
Resolution per revolution	1.048.576 (20 bit)
Number of Multiturn revolutions	–
SIL level	SIL2

Tab. 17: Technical data of the HIPERFACE DSL[®] absolute encoder (Singleturn)

9.4.5 Technical data of the HIPERFACE DSL[®] absolute encoder (Multiturn)

HIPERFACE DSL[®] absolute encoder (Multiturn)	
Ordering code AVF xxxx-xxxxxxx-xHxxxxxxx-xxx	
Type	EKM36
Operating voltage	7 - 12 V
Interface	HIPERFACE DSL [®]
Number of SinCos periods per revolution	–
Resolution per revolution	1.048.576 (20 bit)
Number of Multiturn revolutions	4096 (12 bit)
SIL level	SIL2

Tab. 18: Technical data of the HIPERFACE DSL[®] absolute encoder (Multiturn)

9.4.6 Technical data of the EnDat 2.1 absolute encoder (Singleturn)

EnDat 2.1 absolute encoder (Singleturn)	
Ordering code AVF xxxx-xxxxxxx-xSxxxxxxx-xxx	
Type	ECN 1113
Operating voltage	3.6 - 14 V
Interface	Endat 2.2 / EnDat01
Number of SinCos periods per revolution	512
Resolution per revolution	8192 (13 bit)
Number of Multiturn revolutions	–
SIL level	–

Tab. 19: Technical data of the EnDat 2.1 absolute encoder (Singleturn)

9.4.7 Technical data of the EnDat 2.1 absolute encoder (Multiturn)

EnDat 2.1 absolute encoder (Multiturn)	
Ordering code AVF xxxx-xxxxxxx-xMxxxxxxx-xxx	
Type	EQN 1125
Operating voltage	3.6 - 14 V
Interface	Endat 2.2 / EnDat01
Number of SinCos periods per revolution	512
Resolution per revolution	8192 (13 bit)
Number of Multiturn revolutions	4096 (12 bit)
SIL level	–

Tab. 20: Technical data of the EnDat 2.1 absolute encoder (Multiturn)

9.4.8 Technical data of the EnDat 2.2 absolute encoder (Singleturn)

EnDat 2.2 absolute encoder (Singleturn)	
Ordering code AVF xxxx-xxxxxxx-xFxxxxxxx-xxx	
Type	ECN 1123
Operating voltage	3.6 - 14 V
Interface	Endat 2.2 / EnDat22
Number of SinCos periods per revolution	–
Resolution per revolution	8.388.608 (23 bit)
Number of Multiturn revolutions	–
SIL level	SIL2

Tab. 21: Technical data of the EnDat 2.2 absolute encoder (Singleturn)

9.4.9 Technical data of the EnDat 2.2 absolute encoder (Multiturn)

EnDat 2.2 absolute encoder (Multiturn)	
Ordering code AVF xxxx-xxxxxxx-xWxxxxxxx-xxx	
Type	EQN 1135
Operating voltage	3.6 - 14 V
Interface	Endat 2.2 / EnDat22
Number of SinCos periods per revolution	–
Resolution per revolution	8.388.608 (23 bit)
Number of Multiturn revolutions	4096 (12 bit)
SIL level	SIL2

Tab. 22: Technical data of the EnDat 2.2 absolute encoder (Multiturn)

9.4.10 Technical data of the HIPERFACE® absolute encoder (Singleturn) (compatible with Rockwell)

HIPERFACE® absolute encoder (Singleturn) (compatible with Rockwell)	
Ordering code AVF xxxx-xxxxxxx-xExxxxxxx-xxx	
Type	SKS36S
Operating voltage	7 – 12 V
Interface	HIPERFACE®
Number of SinCos periods per revolution	128
Resolution per revolution	4096 (12 bit)
Number of Multiturn revolutions	–
SIL level	SIL2

Tab. 23: Technical data of the HIPERFACE® absolute encoder (Singleturn) (compatible with Rockwell)

9.4.11 Technical data of the HIPERFACE® absolute encoder (Multiturn) (compatible with Rockwell)

HIPERFACE® absolute encoder (Multiturn) (compatible with Rockwell)	
Ordering code AVF xxxx-xxxxxxx-xVxxxxxxx-xxx	
Type	SKM36S
Operating voltage	7 – 12 V
Interface	HIPERFACE®
Number of SinCos periods per revolution	128
Resolution per revolution	4096 (12 bit)
Number of Multiturn revolutions	4096 (12 bit)
SIL level	SIL2

Tab. 24: Technical data of the HIPERFACE® absolute encoder (Multiturn) (compatible with Rockwell)

9.4.12 Technical data of the HIPERFACE DSL® absolute encoder (Singleturn) (compatible with Rockwell)

HIPERFACE DSL® absolute encoder (Singleturn) (compatible with Rockwell)	
Ordering code AVF xxxx-xxxxxxx-xJxxxxxxx-xxx	
Type	EKS36
Operating voltage	7 - 12 V
Interface	HIPERFACE DSL®
Number of SinCos periods per revolution	–
Resolution per revolution	1.048.576 (20 bit)

HIPERFACE DSL [®] absolute encoder (Singleturn) (compatible with Rockwell)	
Ordering code AVF xxxx-xxxxxxx-xJxxxxxxx-xxx	
Number of Multiturn revolutions	–
SIL level	SIL2

Tab. 25: Technical data of the HIPERFACE DSL[®] absolute encoder (Singleturn) (compatible with Rockwell)

9.4.13 Technical data of the HIPERFACE DSL[®] absolute encoder (Multiturn) (compatible with Rockwell)

HIPERFACE DSL [®] absolute encoder (Multiturn) (compatible with Rockwell)	
Ordering code AVF xxxx-xxxxxxx-xPxxxxxxx-xxx	
Type	EKM36
Operating voltage	7 - 12 V
Interface	HIPERFACE DSL [®]
Number of SinCos periods per revolution	–
Resolution per revolution	1.048.576 (20 bit)
Number of Multiturn revolutions	4096 (12 bit)
SIL level	SIL2

Tab. 26: Technical data of the HIPERFACE DSL[®] absolute encoder (Multiturn) (compatible with Rockwell)

9.4.14 Technical data of temperature sensor PTC

PTC STM 160	
Ordering code: AXV xxxx-xxxxxxx-xxPxxxxxxx-xxx	
Deactivation in case of fault	
Characteristic line in accordance with DIN 44081/44082	
Temperature [°C]	Resistance [ohm]
< 140	20 - 250
140 - 155	250 - 550
155 - 165	550 - 1330
165 - 175	1330 - 4000
> 175	> 4000

Tab. 27: Technical data of temperature sensor PTC

9.4.15 Technical data of temperature sensors KTY and PT 1000

Type	KTY 84-130	PT 1000
Ordering code:	AVF xxxx-xxxxxxx-xxKxxxxxxx-xxx	AVF xxxx-xxxxxxx-xxTxxxxxxx-xxx
Temperature [°C]	Resistance, type [kohm]	Resistance, type [ohm]
-30	0.391	882.11

Type	KTY 84-130	PT 1000
Ordering code:	AVF xxxx-xxxxxxxx-xxKxxxxxxxx-xxx	AVF xxxx-xxxxxxxx-xxTxxxxxxxx-xxx
-20	0.424	921.57
-10	0.460	960.86
0	0.498	1000
10	0.538	1039.03
20	0.581	1077.94
25	0.603	1097.4
30	0.626	1116.73
40	0.672	1155.41
50	0.722	1193.97
60	0.773	1232.42
70	0.826	1270.75
80	0.882	1308.97
90	0.940	1347.07
100	1.000	1385.06
110	1.062	1422.93
120	1.127	1460.68
130	1.194	1498.32
140	1.262	1535.84
150	1.334	1573.25
160	1.407	1610.54
170	1.482	1647.72
180	1.560	1684.78
190	1.640	1721.73
200	1.722	1758.56

Tab. 28: Technical data of temperature sensors KTY and PT 1000

9.4.16 Technical data of the brake

Ordering code: AVF xxxx-xxxxxxxx-xxxxBxxxx-xxx				
	Unit	AVF 1	AVF 2	AVF 3
Voltage	V DC	24		24
Power consumption	A DC	0.42		0.58
Holding torque at 120 °C	Nm	0.78		2.86

Ordering code: AVF xxxx-xxxxxxx-xxxxBxxxx-xxx				
	Unit	AVF 1	AVF 2	AVF 3
Opening time	msec	20		30
Closing time	msec	14		20

Tab. 29: Technical data of the brake

The listed opening and closing times are noted without the use of an additional brake wiring.

Tip

To avoid interfering signals from the switching of the brake, in general an additional wiring should be added, e.g. in the form of a varistor. Observe the requirements of the manufacturer of the servo controller.

9.4.17 Connection cables and cable allocation

The servo actuator is designed as standard with open cable ends.

Signal cable for servo actuators with electrical connection, K = Cable gland, 2-cables

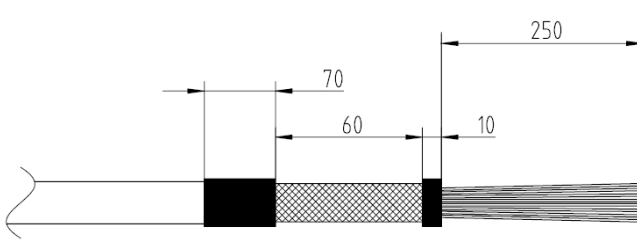
Signal cable resolver				
Ordering code: AVF xxxS-xxxxxxx-x(.)*xxxxKxx-G02 CASI Avxx(.)*-PH000-xHFx-LxxxB Encoder (.)* = R				
	Cross-section	Signal	Cable color	
	3x(2xAWG28)	Sin/S2	white	
		Sin-low/S4	brown	
		Cos/S1	green	
		Cos-low/S3	yellow	
		Ref/R1	gray	
		Ref-low/R2	pink	
	6xAWG28	-	blue	
		-	red	
		-	violet	
		-	black	
		-	white-green	
		-	brown-green	
	2xAWG24	Temp+ (optional*)	white-yellow	
		Temp- (optional*)	yellow-brown	
	2xAWG20	-	gray-pink	
		-	red-blue	
	Cable structure: 3x(2xAWG28) + 1x6xAWG28 + 1x2xAWG24 + 1x2xAWG20 weight: 0.115 kg/m			
	* only versions with pin assignment 1			

Tab. 30: Resolver signal cable assignment

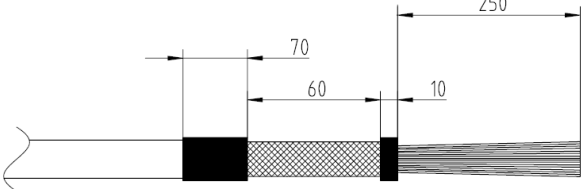
Signal cable EnDat 2.1				
Ordering code: AVF xxxS-xxxxxxx-x(.)*xxxxKxx-G02 CASI Avxx(:)*-PH000-xHFx-LxxxB Encoder (.)* = S / M Encoder (:)* = M				
	Cross-section	Signal	Cable color	
	3x(2xAWG28)	A	white	
		A*	brown	
		B	green	
		B*	yellow	
		data	gray	
		data*	pink	
	6xAWG28	clock	blue	
		clock*	red	
		P- Sense (5V- Sense / Sensor UP)	violet	
		M- Sense (0V- Sense / Sensor 0V)	black	
		-	white- green	
		-	brown- green	
	2xAWG24	Temp+ (optional ¹⁾)	white- yellow	
		Temp- (optional ¹⁾)	yel- low-b rown	
	2xAWG20	P- Encoder (UP)	gray- pink	
		M- Encoder (0V)	red-blue	
	Cable structure: 3x(2xAWG28) + 1x6xAWG28 + 1x2xAWG24 + 1x2xAWG20 weight: 0.115 kg/m			
	¹⁾ only versions with pin assignment 1			

Tab. 31: EnDat 2.1 signal cable assignment

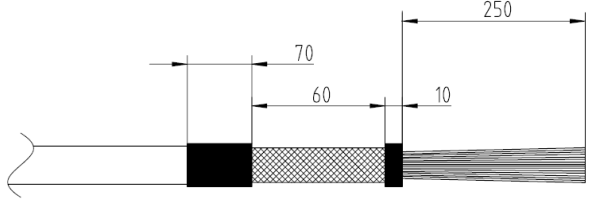
Signal cable EnDat 2.2				
Ordering code: AVF xxxS-xxxxxxx-x(.)*xxxxKxx-G02 CASI Avxx(:)*-PH000-xHFx-LxxxB Encoder (.)* = F / W Encoder (:)* = W				
	Cross-section	Signal	Cable color	
	3x(2xAWG28)	-	white	
		-	brown	
		-	green	
		-	yellow	
		data	gray	
		data*	pink	
	6xAWG28	clock	blue	
		clock*	red	
		P- Sense (5V-Sense / Sensor UP)	violet	
		M- Sense (0V-Sense / Sensor 0V)	black	
		-	white-green	
		-	brown-green	
	2xAWG24	Temp+ (optional ¹⁾)	white-yellow	
		Temp- (optional ¹⁾)	yellow-brown	
	2xAWG20	P- Encoder (UP)	gray-pink	
		M- Encoder (0V)	red-blue	
	Cable structure: 3x(2xAWG28) + 1x6xAWG28 + 1x2xAWG24 + 1x2xAWG20 weight: 0.115 kg/m			
	¹⁾ only versions with pin assignment 1			

Tab. 32: EnDat 2.2 signal cable assignment

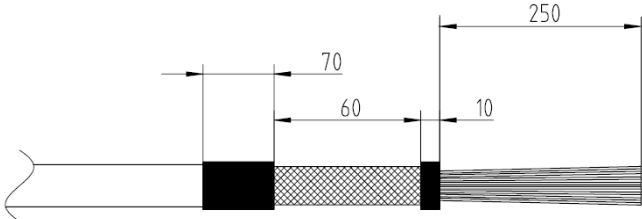
Signal cable HIPERFACE®				
Ordering code: AVF xxxS-xxxxxxx-x(.)*xxxxKxx-G02 CASI Avxx(:)*-PH000-xHFx-LxxxB Encoder (.)* = N / K / E / V Encoder (:)* = K / V				
	Cross-section	Signal	Cable color	
	3x(2 x AWG28)	SIN	white	
		REFSIN	brown	
		COS	green	
		REFCOS	yellow	
		Data +	gray	
		Data -	pink	
	6xAWG28	-	blue	
		-	red	
		-	violet	
		-	black	
		-	white-green	
		-	brown-green	
	2xAWG24	Temp+ (optional*)	white-yellow	
		Temp- (optional*)	yellow-brown	
	2xAWG20	7 - 12 V	gray-pink	
		GND	red-blue	
	Cable structure: 3x(2xAWG28) + 1x6xAWG28 + 1x2xAWG24 + 1x2xAWG20 weight: 0.115 kg/m			
	* only versions with pin assignment 1			

Tab. 33: Assignment of HIPERFACE signal cable

Power cable for servo actuators with electrical connection, K = Cable gland, 2-cables

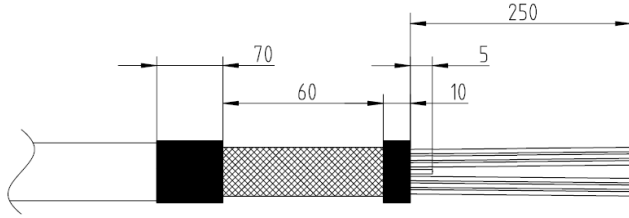
Power cable			
Ordering code: AVF xxxS-xxxxxxx-x(.)*xxxxKxx-G02 CAPO AVxxU-PH015-xHFx-LxxxB Encoder (.)* = R / S / M / F / W / N / K / L / D / E / V			
			
Cross-section	Signal	Wire	
		Cable color	Printing
4x 1.5 mm ²	U	black	U/L1
	V	black	V/L2
	W	black	W/L3
	Earth conductor	green-yellow	-
2x 0.75 mm ²	Brake+ (optional)	black	5
	Brake- (optional)	black	6
2x 0.34 mm ²	Temp+ (optional*)	blue	-
	Temp- (optional*)	white	-
Cable structure: 4G1.5+(2x0.34)+(2x0.75)+hollow conductor weight: 0.25 kg/m			
* only versions with pin assignment 4			

Tab. 34: Power cable assignment

Tip

Observe the information on the direction of rotation (see chapter [9.4.19 Direction of rotation](#)).

Hybrid cable for servo actuators with electrical connection, C = Cable gland, 1-cable

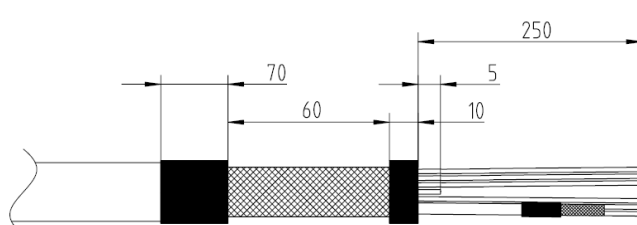
Hybrid cable			
Ordering code: AVF xxxS-xxxxxxx-x(.)*xxxxCxx-G02 CAHY Avxx(:)*-PH015-xHFx-LxxxB Encoder (.)* = G / H / J / P Encoder (:)* = H / P			
			
Cross-section	Signal	Wire	
		Cable color	Printing
4x 1.5 mm ²	U	black	U/L1
	V	black	V/L2
	W	black	W/L3
	Earth conductor	green-yellow	-
2x 0.75 mm ²	Brake+ (optional)	black	5
	Brake- (optional)	black	6
2x 0.34 mm ²	Us/DSL+	white	-
	GND/DSL-	blue	-
Cable structure: 4G1.5+(2x0.34)+(2x0.75)+hollow conductor weight: 0.25 kg/m			

Tab. 35: Hybrid cable assignment

Tip

Observe the information on the direction of rotation (see chapter 9.4.19 [Direction of rotation](#)).

9.4.18 Current carrying capacity of cables

For ambient temperatures up to +40°C, the following applies for cables according to DIN EN 60204-1, table 6 for installation type C:

Continuous stall current	Cables
0 – 15 A _{eff}	4 x 1.5 mm ²
15 – 21 A _{eff}	4 x 2.5 mm ²
21 – 36 A _{eff}	4 x 6 mm ²
36 – 50 A _{eff}	4 x 10 mm ²
50 – 66 A _{eff}	4 x 16 mm ²

Tab. 36: Current carrying capacity of cables

NOTICE



The maximum cable length must not exceed 50 m.

9.4.19 Direction of rotation

The servo actuators have the following direction of rotation in the standard version:

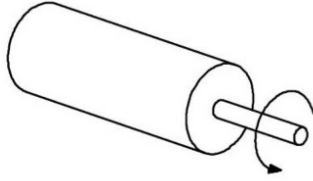
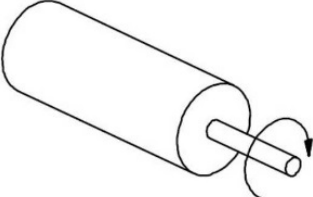
Encoder	Pin assignment	Direction of rotation at phase sequence U-V-W *
Resolver (R)	1 / 4	
EnDat 2.1 (S / M)	1 / 4	
EnDat 2.2 (F / W)	1 / 4	
HIPERFACE® (N / K / E / V)	1 / 4	
HIPERFACE DSL® (G / H / J / P)	1	
* Observe the phase sequence of the used converter. A different phase sequence leads to a different direction of rotation.		

Tab. 37: Direction of rotation of axenia

Revision history

Revision	Date	Comment	Chapter
01	02/28/2023	New version	All
02	05/31/2023	Layout adjustment	All



alpha

WITTENSTEIN alpha GmbH · Walter-Wittenstein-Str. 1 · D-97999 Igersheim · Germany
Tel. +49 7931 493-0 · info@wittenstein.de

WITTENSTEIN - one with the future

www.wittenstein-alpha.de