

MRS/ARS/TPM

Rotating electrical machines
for use in areas with explosion hazards

Operating Manual



© **WITTENSTEIN cyber motor GmbH 2021**

Diese Dokumentation ist urheberrechtlich geschützt.

Alle Rechte, auch die der fotomechanischen Wiedergabe, der Vervielfältigung und der Verbreitung mittels besonderer Verfahren (zum Beispiel Datenverarbeitung, Datenträger und Datennetze), auch teilweise, behält sich die **WITTENSTEIN cyber motor GmbH** vor.

Inhaltliche und technische Änderungen vorbehalten.

This documentation is copyright protected.

WITTENSTEIN cyber motor GmbH reserves all rights to photo-mechanical reproduction, copying, and the distribution by special processes (such as computers, file media, data networks), in whole or in part.

Subject to technical and content changes without notice.

Questa documentazione è protetta dai diritti d'autore.

WITTENSTEIN cyber motor GmbH si riserva tutti i diritti, anche quelli relativi alla riproduzione fotomeccanica, alla riproduzione e alla diffusione, anche parziali, eseguite secondo processi particolari (quali ad es. l'elaborazione di dati, il supporto dati e le reti di dati).

Con riserva di modifiche tecniche e di contenuto.

Cette documentation est protégée par copyright.

Tous les droits de reproduction même partielle, de diffusion et de transmission photomécanique ainsi que par des procédés techniques spéciaux. (tels le traitement de données, les supports et réseaux de données) sont réservés à **WITTENSTEIN cyber motor GmbH**.

Sous réserve de modifications techniques et de fond.

Este documento es propiedad registrada.

WITTENSTEIN cyber motor GmbH se reserva todos los derechos de reproducción fotomecánica, copia y divulgación, también en forma de extractos y por procedimientos especiales (como editores de datos, memorias de datos y redes de datos).

Sujeto a modificaciones técnicas y de contenido sin previo aviso.

本ドキュメントは著作権で保護されています。

写真製版の複製、特別な手続き（データ処理、データキャリア、データネットワーク等）を介した複製と配布（抜粋を含む）に関する全ての権利は

WITTENSTEIN cyber motor GmbH に帰属します。

本取扱説明書の記載内容、及び技術的内容は予告なく変更されることがあります。

Kontakt / Contact / Contatti / Contact / Contacto

DE

Bei technischen Fragen wenden Sie sich an folgende Adresse:

WITTENSTEIN cyber motor GmbH

Vertrieb

Walter-Wittenstein-Straße 1

D-97999 Igersheim

Tel.: +49 7931 493-15800

Fax: +49 7931 493-10905

E-mail: vertrieb@wittenstein-cyber-motor.de

Bei technischen Störungen wenden Sie sich an folgende Adresse:

WITTENSTEIN cyber motor GmbH

Customer Service

Walter-Wittenstein-Straße 1

D-97999 Igersheim

Tel.: +49 7931 493-15900

Fax: +49 7931 493-10903

E-mail: service@wittenstein-cyber-motor.de

GB

If you have technical questions, please contact us under the following address:

WITTENSTEIN cyber motor GmbH

Sales department

Walter-Wittenstein-Straße 1

D-97999 Igersheim

Tel.: +49 7931 493-15800

Fax: +49 7931 493-10905

E-mail: vertrieb@wittenstein-cyber-motor.de

In the event of technical malfunctions, please contact us under the following address:

WITTENSTEIN cyber motor GmbH

Customer Service

Walter-Wittenstein-Straße 1

D-97999 Igersheim

Tel.: +49 7931 493-15900

Fax: +49 7931 493-10903

E-mail: service@wittenstein-cyber-motor.de

US

If you have technical questions, please contact us under the following address:

WITTENSTEIN Inc.

Sales department

1249 Humbracht Circle

Bartlett, IL 60103

USA

Tel.: +1 630 540 5300

E-mail: support.cyber@wittenstein-us.com

In the event of technical malfunctions, please contact us under the following address:

WITTENSTEIN Inc.

Customer Service

1249 Humbracht Circle

Bartlett, IL 60103

USA

Tel.: +1 630 540 5300

E-mail: customerservice@wittag.net

**IT**

Per informazioni tecniche rivolgersi al seguente indirizzo:

WITTENSTEIN S.P.A.

Ufficio vendite
Via Giosuè Carducci 125
20099 Sesto San Giovanni MI
Italy

Tel.: +39 02 241357-1

Fax: +39 02 700 462 39

E-mail: info@wittenstein.it

In caso di problemi tecnici rivolgersi al seguente indirizzo:

WITTENSTEIN S.P.A.

Customer Service
Via Giosuè Carducci 125
20099 Sesto San Giovanni MI
Italy

Tel.: +39 02 241357-1

Fax: +39 02 700 462 39

E-mail: info@wittenstein.it

FR

Pour toutes questions techniques, s'adresser à :

WITTENSTEIN cyber motor GmbH

Service commercial
Walter-Wittenstein-Straße 1
D-97999 Igersheim

Tel.: +49 7931 493-15800

Fax: +49 7931 493-10905

E-mail: vertrieb@wittenstein-cyber-motor.de

En cas de défaillance technique, s'adresser à l'adresse suivante :

WITTENSTEIN cyber motor GmbH

Service clientèle
Walter-Wittenstein-Straße 1
D-97999 Igersheim

Tel.: +49 7931 493-15900

Fax: +49 7931 493-10903

E-mail: service@wittenstein-cyber-motor.de

ES

Si tiene preguntas técnicas, póngase en contacto con la siguiente dirección:

WITTENSTEIN cyber motor GmbH

Departamento de Ventas
Walter-Wittenstein-Straße 1
D-97999 Igersheim

Tel.: +49 7931 493-15800

Fax: +49 7931 493-10905

E-mail: vertrieb@wittenstein-cyber-motor.de

En caso de ser necesaria una reparación, póngase en contacto con la siguiente dirección:

WITTENSTEIN cyber motor GmbH

Customer Service
Walter-Wittenstein-Straße 1
D-97999 Igersheim

Tel.: +49 7931 493-15900

Fax: +49 7931 493-10903

E-mail: service@wittenstein-cyber-motor.de

Contents

1	About this manual	3
1.1	Signal words	3
1.2	Safety symbols	4
1.3	Design of the safety instructions	4
1.4	Information symbols	4
2	Safety	5
2.1	EU Directive	5
2.2	Dangers	5
2.3	Personnel	5
2.4	Intended use	6
2.5	Guarantee and liability	6
2.6	Other applicable documents	6
2.7	General safety instructions	6
3	Description of the motor	9
3.1	General information	9
3.2	Identification plate	9
3.3	Ex model	10
3.3.1	Marking	10
3.3.2	Additional requirements	11
3.4	Performance data	11
3.5	Temperature monitoring	13
3.6	Induced terminal voltage	14
3.7	Weight	14
4	Transport and storage	15
4.1	Scope of delivery	15
4.2	Packaging	15
4.3	Transport	15
4.4	Storage	15
5	Assembly	16
5.1	Preparations	16
5.2	Attaching Motor to a machine	17
5.2.1	Attaching a MRS motor to a machine	17
5.2.2	Attaching TPM ⁺ motor to a machine	18
5.2.3	Attaching ARS motor to a machine	18
5.3	Components mounted to the output side	19
5.4	Installing the electrical connections	19
5.4.1	Motors with flying lead	21
5.4.2	Motors with internal terminal strip	21
5.4.3	Motors with external earth conductor connection	23
6	Startup and operation	24
6.1	Safety information and environmental conditions	24
6.1.1	Humidity / Temperature	24
6.1.2	Vibration	24
6.1.3	Shock	25
6.1.4	Chemical resistance	25
6.1.5	Holding brake	25
6.1.6	Check running-in behavior (for ARS and TPM ⁺ only)	27
6.2	Operation	27
6.2.1	Operation with PWM converter	28
7	Maintenance, repairs and disposal	29
7.1	Maintenance work	29
7.1.1	Cleaning	29
7.1.2	Checking the holding brake	29

- 7.1.3 Visual inspection..... 29
- 7.1.4 Checking for leakage (ARS only)..... 29
- 7.1.5 Inspection 30
- 7.2 Start-up after maintenance work 30
- 7.3 Note on repairs..... 30
 - 7.3.1 Repainting..... 30
- 7.4 Disposal..... 30
- 8 Malfunctions 31**
- 9 Declarations of conformity 32**
 - 9.1 Declaration of conformity MRSR064A-030C-4D5DF-EI0GEG-NNN..... 32
 - 9.2 Declaration of conformity MRSH064A-105C-6D0DF-RA0PEW-NNN..... 33
 - 9.3 Declaration of conformity MRSH064A-105C-6D3DF-RA0PEW-NNN..... 34
 - 9.4 Declaration of conformity MRSH064A-105C-9D7SF-RA0PEW-NNN 35
 - 9.5 Declaration of conformity MRSR094A-135C-2V7DF-EI0PEW-NNN..... 36
 - 9.6 Declaration of conformity MRSH155A-165C-3V5SF-FM1GEW-NNN..... 37
 - 9.7 Declaration of conformity ARSQ064A-030C-4D5DF-EI0GEG-BNN 38
 - 9.8 Declaration of conformity TPMP010x-016K-6PB1-094C-W4-x01 39
 - 9.9 Declaration of conformity TPM 050X-016K-6PB1-130D-W4-X01 40
- 10 Appendix 41**
 - 10.1 Specifications for mounting onto a machine..... 41
 - 10.1.1 Specifications for mounting to a machine (MRS)..... 41
 - 10.1.2 Specifications for mounting onto a machine (TPM⁺)..... 41
 - 10.1.3 Specifications for mounting onto a machine (ARS) 41
 - 10.2 Tightening torques for common thread sizes in
general mechanical engineering..... 42
 - 10.3 Tightening torques for common thread sizes with
corrosion-resistant screw connections..... 42

1 About this manual

This operating manual contains necessary information for the safe operation of the explosion-protected servo motor MRS or the explosion-protected motor-gearbox combination TPM⁺ / ARS, referred to as motor in the following.

Every explosion protected motor is identified uniquely with its article code (AC) and serial number (SN) (also see chapter 3.2 "Identification plate").

In case of conflict between this general operating manual and the product-specific documentation, the product-specific documentation applies. This operating manual is valid for the product (motor) unless another, product-specific documentation exists.

The operator must ensure that these instructions are read through by all persons assigned to install, operate, or maintain the motor, and that they fully comprehend them.

Store these instructions within reach of the motor.

These **safety instructions** should be shared with colleagues working in the vicinity of the device to ensure individual safety.

The original instructions were prepared in German; all other language versions are translations of these instructions.

1.1 Signal words

The following signal words are used to indicate possible hazards, prohibitions, and important information:

	⚠ DANGER
	This signal word indicates an imminent danger that will cause serious injuries or even death.
	⚠ WARNING
	This signal word indicates a potential hazard that could cause serious injuries and even death.
	⚠ CAUTION
	This signal word indicates a potential hazard that could cause minor or serious injuries.
	NOTICE
	This signal word indicates a potential hazard that could lead to material damage.
	A note without signal word draws your attention to application tips or especially important information when handling the motor.

1.2 Safety symbols

The following safety symbols are used to indicate possible hazards, prohibitions, and important information:



General danger



Hot surface



Suspended loads



Entanglement



Electrostatic sensitive device



Information



Explosion



Electric voltage



Crushing hazard



Pacemaker ban

1.3 Design of the safety instructions

The safety instructions of these instructions are designed according to the following pattern:

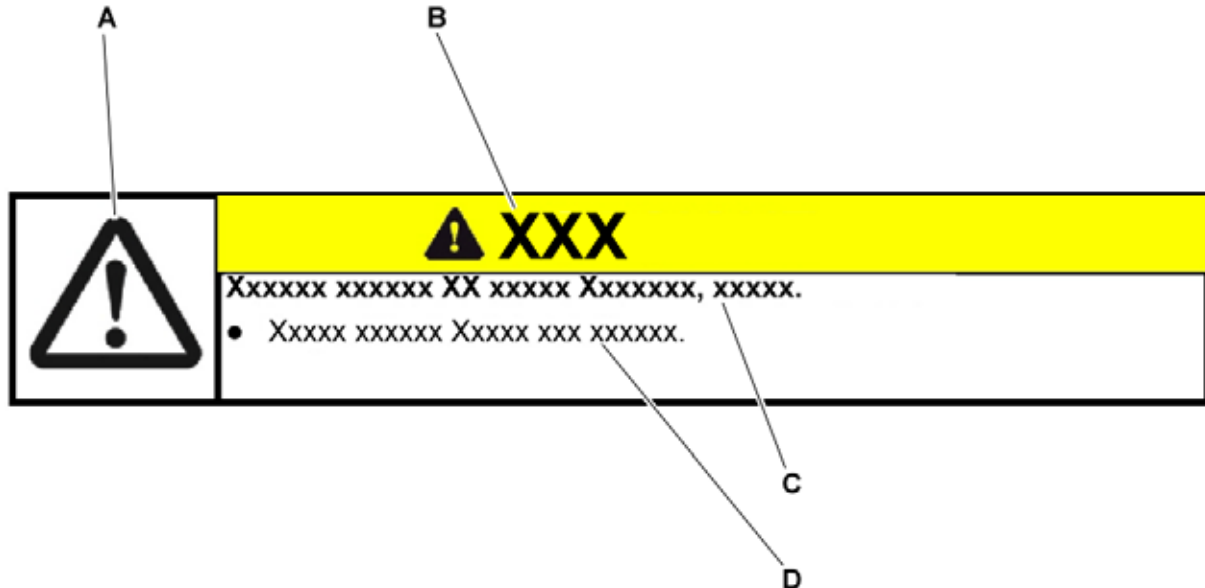

A = Safety symbol (see Chapter 1.2 "Safety symbols")

B = Signal word (see Chapter 1.1 "Signal words")

C = Type and consequence of the danger

D = Prevention of the danger

1.4 Information symbols

The following information symbols are used:

- Indicates an action to be performed
- ➡ Indicates the results of an action
- ① Provides additional information on handling

2 Safety

This instruction, in particular the safety notes, and the rules and regulations applicable at the usage site are to be observed by all individuals working with the motor.

In addition to the safety instructions in this manual, also observe any (legal and otherwise) applicable environmental and accident prevention rules and regulations (e.g. personal safety equipment).

2.1 EU Directive

The motor has been constructed in accordance with the relevant EU directives for the relevant model and design. The motor complies with all applicable EU regulations. The motor bears the CE marking to the extent required by applicable EU regulations.

Observe applicable regulations for electrical installation (e.g. wire cross-sections, fuses).

It is the responsibility of the plant builder to ensure that all requirements that apply to the entire system are fulfilled.

The EC declaration of conformity can be found in Chapter 9 "Declarations of conformity". You can receive the declaration of conformity on request from our sales department. Always provide the serial number in this case.

The motor and all of its individual components are RoHS compliant and in accordance with Directive 2011/65/EC. This applies in particular with regard to the following substances:

1. Lead
2. Mercury
3. Cadmium
4. Hexavalent chromium
5. Polybrominated biphenyls (PBB)
6. Polybrominated diphenyl ether (PBDE)

A RoHS declaration of conformity can be issued upon request.

2.2 Dangers

The motor has been built in accordance with the current state of the art and the generally accepted safety engineering practice.

The motor may be used for its intended purpose (ref. chapter 2.4 "Intended use") and in a flawless condition with regard to safety only in order to avoid danger to the user or damage to the machine.

- Read the general safety instructions before beginning work (see Chapter 2.7 "General safety instructions").

2.3 Personnel

All work on explosion-protected electric drives may be carried out only by competent personnel.

The qualification required for "competent personnel" is described in DIN EN 60079-17:

Inspection, maintenance and repair of equipment subject to this standard may only be carried out by experienced personnel having received training regarding the various ignition protection classes and installation procedures, the requirements of this standard, applicable national regulations and company rules for the system as well as the general zoning principles. The personnel is required to take part in adequate regular training. Proof of relevant experience and completed training sessions must be documented and made available.

2.4 Intended use

The motor is designed for use in industrial systems and suitable for use in areas with explosion hazards according to the marking on the identification plate.

The technical specifications as well as information on the permissible conditions can be found on the identification plate and in this operating manual.

The motor is intended for operation on a suitable converter. For the parameterization and selection of the converter, the specifications in Chapter 6.2.1 "Operation with PWM converter" must be observed. The motor may only be operated in field weakening if an explicit approval for this is indicated in the motor speed and torque characteristics (5012-...).

The motor can be optionally equipped with a holding brake.

- A holding brake is no safety brake, as defined by DIN EN 13849-1 or by the German BGHM regarding hanging axes (only available in German), and is therefore not intended to be used as a brake for the protection of persons or as a dynamic brake.

2.5 Guarantee and liability

Guarantee and liability claims are excluded for personal injury and material damage in case of

- Ignoring the information on transport and storage
- Improper use (misuse)
- Improper or neglected maintenance and repair
- Improper assembly / disassembly or improper operation
- Operation of the motor with defective protection devices and mechanisms
- Operation of a severely soiled motor
- Changes or modifications that have been realized without the written approval of **WITTENSTEIN cyber motor GmbH**

2.6 Other applicable documents

You have already received the following documents for your specific motor:







- Customer drawing (5007-...)
- Signal list (5085-...)
- Motor speed and torque characteristics (5012-...)

For additional information, please contact our sales department. Always provide the serial number in this case.

The EC declaration of conformity can be found in chapter 9 "Declarations of conformity".

2.7 General safety instructions

	⚠ DANGER
	<p>Operating the motor in areas for which it is not approved leads to explosions that cause serious injuries and even death.</p> <ul style="list-style-type: none"> • Always ensure that the motor is only used in those areas for which it is permitted according to the identification plate (see Chapter 3.2 "Identification plate").

	<p style="text-align: center;">⚠ DANGER</p> <p>Faulty electrical connections or unapproved, current-carrying components can lead to explosions that can cause serious injuries and even death.</p> <ul style="list-style-type: none"> • Have all electrical connection work performed by trained technicians only. The valid standards and directives must be observed for this. • Use only converters that meet the requirements according to Chapter 6.2.1 "Operation with PWM converter". • All cable ends must be guided out of the area with the explosion hazard or, if connected inside the explosion hazard area, be connected to an approved and certified terminal box. • A strain relief of the cables and the line infeed needs to be ensured. • Do not take the motor into operation with any damaged cables or plugs. In this case, please contact WITTENSTEIN cyber motor GmbH.
	<p style="text-align: center;">⚠ WARNING</p> <p>When the motor shaft is still turning or when the motor is externally driven (generator operation), voltage is induced. This can cause lethal current surges.</p> <ul style="list-style-type: none"> • Ensure that no plugs or connections are exposed.
	<p style="text-align: center;">⚠ WARNING</p> <p>Objects flung out by moving components can cause serious injuries and death.</p> <ul style="list-style-type: none"> • Remove objects and tools from the motor prior to starting it up.
 	<p style="text-align: center;">⚠ WARNING</p> <p>Moving components on the motor can pull in or crush parts of the body and cause serious injuries and even death.</p> <ul style="list-style-type: none"> • Keep a sufficient distance to moving machine components when the motor is running. • Secure the higher-level machine against restarting and unintentional movements during assembly and maintenance work (e.g. uncontrolled lowering of lifting axes).
	<p style="text-align: center;">⚠ WARNING</p> <p>Power and signal supply lines under voltage must not be disconnected. Risk of machine damage, serious injury or even death.</p> <ul style="list-style-type: none"> • Make sure that the drive is always in a voltage-free state before disconnecting its power and signal supply (e.g. disconnecting the motor connectors).

	⚠ WARNING
	<p>Components equipped with permanent magnets and components that feature magnetic fields can influence/impede the function of active medical implants (e.g. pacemakers, defibrillators). This can lead to severe injuries or even death.</p> <ul style="list-style-type: none"> • Keep a sufficient distance to these components (stator, rotor) during assembly. • If permanent magnets or permanent magnetic fields are directly accessible (especially with rotary kit motors or the primary and secondary parts of linear motors), you are prohibited from approaching these motor parts. • If there are concerns, contact the manufacturer of the active medical implants or consult WITTENSTEIN cyber motor GmbH.

	⚠ WARNING
	<p>A wrong direction of rotation or direction of movement may result in serious injury or death.</p> <p>The direction of rotation or movement may differ from the standard IEC 60034-8.</p> <ul style="list-style-type: none"> • Before and during startup, ensure that the motor has the correct direction of rotation or movement. • Be sure to avoid collision (caused e.g. by crashing against an end stop). • With the danger area secured, check the direction of rotation or movement in a slow motion, ideally by limiting the current and torque.

	⚠ WARNING
	<p>A damaged motor can cause explosions or accidents with the risk of injury.</p> <ul style="list-style-type: none"> • Never operate a motor that has been overloaded due to misuse or a machine crash. • Replace the affected motors, even if no external damage is visible.

	⚠ WARNING
	<p>Additionally attached stickers on the motor housing increase the risk of electrostatic charges which can cause explosions.</p> <ul style="list-style-type: none"> • Do not attach any stickers to the motor housing.

	⚠ CAUTION
	<p>A hot motor housing may cause severe burns.</p> <ul style="list-style-type: none"> • Touch the motor housing with protective gloves or after a longer standstill of the motor only.

3 Description of the motor

3.1 General information

All motors are brushless electrical machines and conform to the applicable standards and regulations, in particular:

- **EN 60034** Rotating electrical machines
- **EN 60079** Explosive atmospheres
- **94/9/EC** ATEX Directive (valid until 19.04.2016 [date of manufacture])
- **2014/34/EU** ATEX Directive (valid from 20.04.2016 [date of manufacture])

3.2 Identification plate

The identification plate is attached to the motor housing.

The identification plate contains important information about the motor characteristics. Customer-specific variations of the design of the identification plate are permissible.

		Designation
		A Type designation (ordering code)
		B CE mark (only if CE identification is obligatory)
		C Number of the notified body that has audited the QA system
		D Serial number
		E Article code
		F Production date (week/year)
		G Insulation class
		H Nominal bus voltage (DC voltage) U_{DC}
		I Continuous torque M_0 at low speeds
		J Phase current I_0 during continuous torque M_0
		K Part number of customer (optional)
		L No-load speed n_0
		M Maximum torque M_{max} at maximum phase current I_{max}
		N Maximum phase current I_{max}
		O Brake: static holding torque and rated voltage (optional)
		P Note on the PTC triggering device to be used
		Q IP protection class
		R Permissible ambient temperature range
		S Gas explosion protection label

Tbl-1: Identification plate (sample values)

		Designation
	T	Converter type and minimal switching frequency f_{SW}
	U	Dust explosion protection label
	V	Tripping time t_A
	W	Tripping current I_{ADC}
	X	Explosion protection label of the gearhead (optional)
	Y	Gearhead ratio (optional)
	Z	Gearhead lubricant used (optional)

Tbl-2: Identification plate (sample values)

3.3 Ex model

3.3.1 Marking

The motors are designed for use in areas with explosion hazards according to their marking:

MRSR064A-030C-4D5DF-EI0GEG-NNN	⚠ II 2 G Ex eb db IIC T4 Gb ⚠ II 2 D Ex tb IIIC T 130 °C Db
MRSH064A-105C-9D7SF-RA0PEG-NNN	⚠ II 2 G Ex db IIC T4 Gb ⚠ II 2 D Ex tb IIIC T 130 °C Db
MRSH064A-105C-6D*DF-RA0PEG-NNN	⚠ II 2 G Ex db IIC T4 Gb ⚠ II 2 D Ex tb IIIC T 130 °C Db
MRSH155A-165C-3V5SF-FM1GEW-NNN	⚠ II 2 G Ex db IIC T4 Gb ⚠ II 2 D Ex IIIC T130°C Db
MRSH094A-135C-2V7DF-EI0PEW-NNN	⚠ II 2 G Ex db IIC T4 Gb ⚠ II 2 D Ex tb IIIC T 130 °C Db
ARSQ064A-030C-4D5DF-EI0GEG-NNN	⚠ II 2 G Ex db eb h IIC T4 Gb ⚠ II 2 D Ex tb h IIIC T 130 °C Db
TPM010F-016K-6PB1-094C-W4	⚠ II 2 D Ex tb IIIC T 130 °C Db
TPM050F-016K-6PB1-130D-W4	⚠ II 2 D Ex tb IIIC T 130 °C Db

Tbl-3: CE mark

3.3.2 Additional requirements

The special conditions concern requirements for repairs at the motor (Chapter 7.3 "Note on repairs") as well as electric commissioning (Chapter 6.2.1 "Operation with PWM converter") and are marked with the "Ex symbol" in the respective chapters.

Additionally, cable connections are only permissible for fixed installations and not suitable for traction forces or bending torques. Suitable clamping connection of the cable must be ensured. Lay the cables in a straight line from the cable and line infeed.

3.4 Performance data

Motor curve

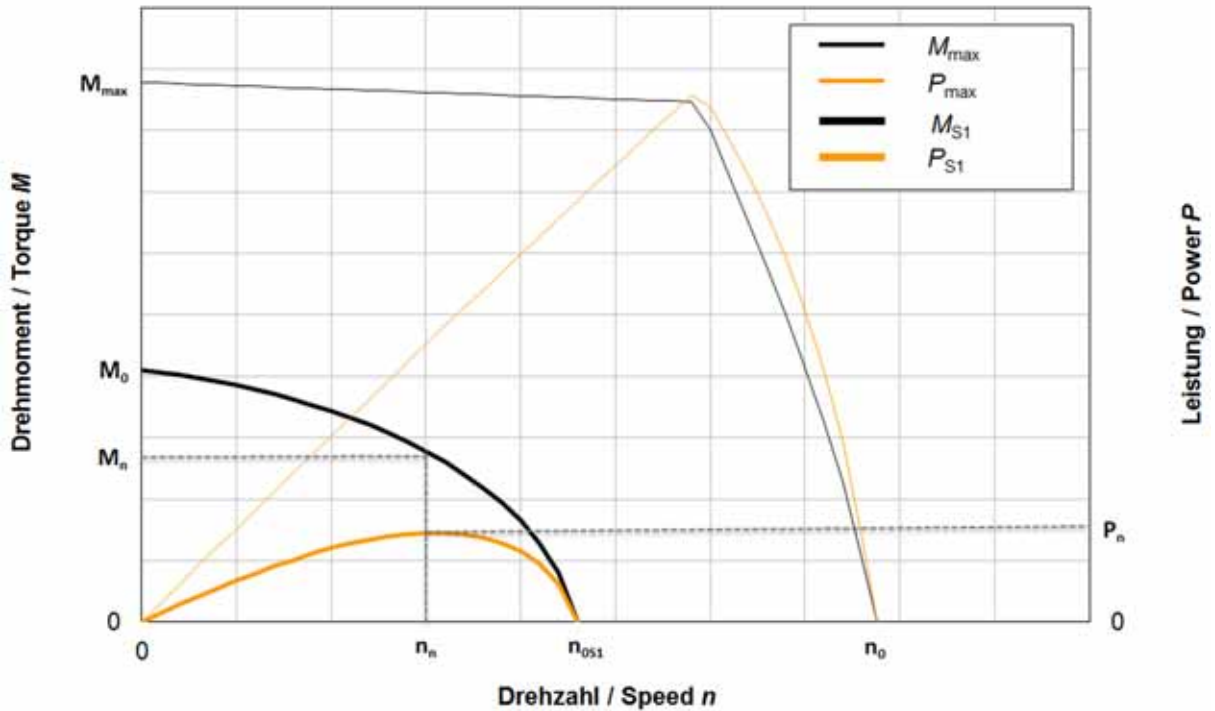

Performance data													
	U_{DC}	ϑ_u	M_{max}	I_{max}	M_0	I_0	n_0	$n_{limit, max}$	n_{0S1}	$n_{limit, S1}$	M_n	n_n	P_n
	[V]	[°C]	[Nm]	[A _{eff}]	[Nm]	[A _{eff}]	[rpm]	[rpm]	[rpm]	[rpm]	[Nm]	[rpm]	[W]
MRSR064A-030C-4D5DF-EI0GEG-NNN	320	40	1.6	3.2	0.8	1.6	7480	–	7480	–	0.54	7060	399
MRSH064A-105C-9D7SF-RA0PEG-NNN	560	40	8.3	6.8	3.6	3.1	5700	–	5700	–	3.1	5300	1743
		80	7.3	6.0	2.4	2.0					1.3	5530	741
MRSH064A-105C-6D*DF-RA0PEG-NNN	320	40	7.95	10.6	3.7	5.1	5200	–	5200	–	3.3	4740	1658
		80	7.5	10.0	2.6	3.4					1.7	4980	881
MRSH155A-165C-3V5SF-FM1GEW-NNN	560	40	91.97	22.5	43.2	10	1486	–	1486	–	28.9	1414	4275
		70	91.14	22.5	25.9	5.82	1495		745		9.9	600	620
		80	90.85	22.5	15.2	3.43	1503		350		4.1	300	128

Performance data													
	U_{DC}	ϑ_u	M_{max}	I_{max}	M_0	I_0	n_0	$n_{limit,max}$	n_{0S1}	$n_{limit,S1}$	M_n	n_n	P_n
	[V]	[°C]	[Nm]	[A _{eff}]	[Nm]	[A _{eff}]	[rpm]	[rpm]	[rpm]	[rpm]	[Nm]	[rpm]	[W]
MRSR094A-135C-2V7DF-EI0PEW-NNN	320	40	22.18	7.5	7.3	2.4	1146	–	1146	–	5.3	1018	565
		80	13.83	4.5	4.8	1.5					2.6	900	244
ARSQ064A-030C-4D5DF-EI0GEG-NNN	320	40	23.0	3.2	11.5	1.4	7480	375	–	375	5.8	344	210
TPMP010X-016K-6PB1-094C-WA-X01	560	40	125.6	10.1	54.8	4.6	7322	458	219	–	26.6	188	522
TPM050X-016K-6PB1-130D-W4-X01	560	40	347.2	28.3	170	12.7	7036	390	153	–	140.2	62.5	918

Tbl-4: Performance data

The performance data listed in Table "Tbl-4" assumes operation of the motor with a suitable converter (see Chapter 6.2.1 "Operation with PWM converter").



NOTICE

If a value for $n_{limit,max}$ is given in Table "Tbl-4", then this represents the permissible maximum motor speed. Exceeding $n_{limit,max}$ leads to damage to motor damage.

- Stating n_0 serves as a design note on the induced terminal voltages (see Chapter 3.6 "Induced terminal voltage").
- If no information about $n_{limit,max}$ is given in Table "Tbl-4", then n_0 is the maximum permissible speed for the motor.

The performance data given in Table "Tbl-4" may not be exceeded.

Information on torques, speeds and currents apply to a thermally conductive installation of the motor on a commercial system without external heat input. If you need information on motor performance for a thermally insulated installation, please contact the sales department. Always provide the serial number of the motor when doing so.

Explanation of the symbols	
Symbol	Meaning
U_{DC}	Bus DC voltage
P_{max}	Maximum power for intermittent duty
M_{max}	Maximum torque at maximum current I_{max}
I_{max}	Maximum current, effective value
M_0	Continuously permissible torque at motor standstill and at three-phase current feed with I_0
I_0	Continuously permissible current (effective value) leading to the permissible heating of the winding
n_0	Maximum speed that is reached load-free without field-weakening when operated with U_{DC} and presuming that there is no mechanical limit (see information on $n_{limit,max}$).

Explanation of the symbols	
Symbol	Meaning
n_{0S1}	Maximum continuously permissible speed that leads to permissible heating up of the winding in load-free state When "-" is specified, the information for $n_{limit,S1}$ applies.
$n_{limit,S1}$	Maximum continuously permissible speed due to mechanical limits When "-" is specified there are no mechanical limits and the information for n_{0S1} applies.
$n_{limit,max}$	Maximum permissible speed due to mechanical limits When "-" is specified there are no mechanical limits and the information for n_0 applies.
M_n	Continuously permissible torque at speed n_n
P_n	Continuously permissible power at speed n_n
n_n	Speed up to which M_n is continuously specified
ϑ_U	Maximum permissible ambient temperature without reduced performance (maximum inlet temperature of the coolant for liquid cooling)

TbI-5: Explanation of the symbols

3.5 Temperature monitoring

The PTC temperature sensors installed in the motor must be monitored by a functionally-tested PTC triggering device with the protection type code $\text{Ex}II(2)G$ for explosive gas atmospheres and $\text{Ex}II(2)D$ for explosive dust atmospheres.

	NOTICE
	The motor must be dimensioned in a size in which the permitted operational temperature is not exceeded even under toughest conditions.

As an option, some motors are equipped with an additional temperature sensor that must be connected to a triggering device or a detection circuit.

	NOTICE
	If temperature monitoring is triggered during operation, the drive must be checked by our Customer Service.

3.6 Induced terminal voltage

The rotors are equipped with permanent magnets for all drives.

	⚠ WARNING
	<p>When the motor shaft is still turning or when the motor is externally driven (generator operation), voltage is induced. This can lead to lethal current surges.</p> <ul style="list-style-type: none"> • Ensure that no plugs and connections are exposed.

The following illustration shows the magnitude of the induced terminal voltage to be expected (effective value) depending on the speed.

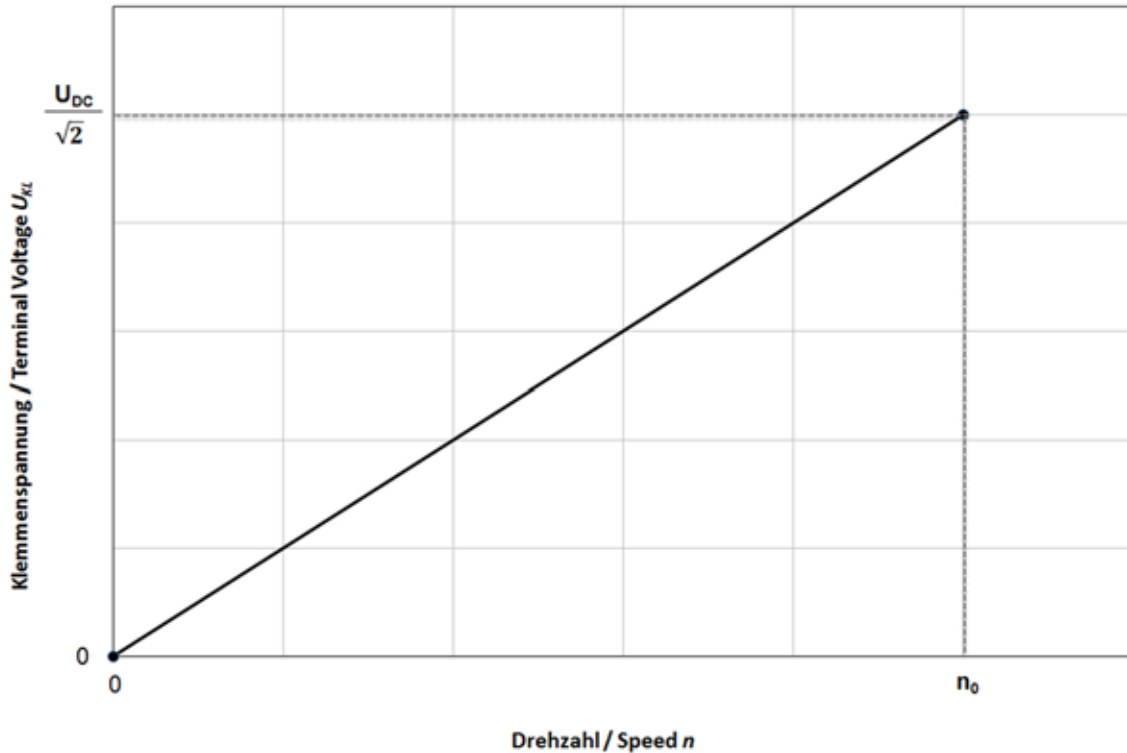

Please see the Table "Tbl-4" in Chapter 3.4 "Performance data" for the values of U_{DC} and n_0 . The figures on the terminal voltage apply to open cable ends.

	! NOTICE
	<ul style="list-style-type: none"> • Ensure that the connected converter is suitable for the induced voltages.

3.7 Weight

The weight of your motor can be found in the supplied motor speed and torque characteristics (5012-...).

4 Transport and storage



4.1 Scope of delivery

- Check the completeness of the delivery against the delivery note.
 - ① Missing parts or damage must be notified immediately in writing to the carrier, the insurance company, or **WITTENSTEIN cyber motor GmbH**.

4.2 Packaging

- Dispose of the packaging materials at the recycling sites intended for this purpose. Observe the applicable national regulations concerning disposal.

4.3 Transport

	<p style="text-align: center;">⚠ WARNING</p> <p>Suspended loads can fall and can cause serious injuries and even death.</p> <ul style="list-style-type: none"> • Do not stand under suspended loads. • Secure the motor before transport with suitable fasteners (e.g. belts).
	<p style="text-align: center;">NOTICE</p> <p>Hard shocks caused by harsh handling during transportation (e.g. falling, hard dropping) can damage the motor.</p> <ul style="list-style-type: none"> • Only use hoisting equipment and lifting accessories with sufficient capacity. • Never exceed the maximum permissible load for hoisting equipment. • Slowly put down the motor.

Note the weight of the payload and use an appropriate transport device.

Specifications on the weights, refer to Chapter 3.7 "Weight".

Ambient temperatures between -20° C and +50° C are permissible for transport only.

4.4 Storage

Store the motor in a horizontal position at a temperature of 0 °C to + 40 °C in the original packaging. The ambient conditions must be dry, dust-free, and low in vibrations (see Chapter 6.1 "Safety information and environmental conditions"). Store the motor for a maximum of 2 years.

For storage logistics, we recommend the "first in - first out" method.

5 Assembly

- Read the general safety instructions before beginning work (see Chapter 2.7 "General safety instructions").

	⚠ DANGER
	<p>Assembling the motor in areas with explosion hazards can lead to explosions that can cause serious injuries and even death.</p> <ul style="list-style-type: none"> • Be certain that there is no explosive atmosphere during assembly.

	⚠ DANGER
	<p>Missing, loose or damaged screws in the motor housing void the explosion protection of the motor. Explosions can cause serious injuries and even death.</p> <ul style="list-style-type: none"> • Use a calibrated torque wrench to tighten and check all screw connections for which a tightening torque has been specified. • Before startup, ensure that all screws have been screwed in.

- Unless explicitly agreed otherwise for customer-specific motors, perform the assembly according to the following sections.

5.1 Preparations

	NOTICE
	<p>Compressed air can damage the motor seals.</p> <ul style="list-style-type: none"> • Do not use compressed air to clean the motor.

	NOTICE
	<p>If present, the temperature sensors and rotor position encoders, particularly Hall Effect sensors and encoders, can be damaged by electrostatic discharge.</p> <ul style="list-style-type: none"> • Observe the directives concerning ESD protection.

- Clean / degrease the output shaft of the motor with a clean and lint-free cloth as well as a grease-dissolving, non-aggressive cleaning agent.
- Dry all fitting surfaces to neighboring components in order to achieve the proper friction values of the screw connections.
- Check the fitting surfaces additionally for damage and impurities.
- Use:
 - Property class 12.9 bolts for TPM⁺ or ARSx094 series motors.
 - Property class Ax-80 stainless steel bolts for ARSx064 series motors
 - For all other motors, use screws with property class 10.9.
- Use:
 - **no** washers for motors with stainless steel flange and TPM⁺ or ARS series motors.
 - Washers (hardness class 300 HV) for motors with an aluminum flange. The contact pressure must not exceed 230 N/mm².

5.2 Attaching Motor to a machine

	<h3>⚠ CAUTION</h3>
	<p>During the mechanical assembly of the motors onto the application, and during mechanical maintenance work, handling errors can lead to severe crushing injuries as well as to damage to the motor or the application.</p> <ul style="list-style-type: none"> • Have all mechanical assembly and maintenance work carried out by trained personnel only. • Only use suitable tools for assembly and maintenance work.

5.2.1 Attaching a MRS motor to a machine

	<ul style="list-style-type: none"> • Observe the safety and processing instructions for the threadlocker to be used.
--	---

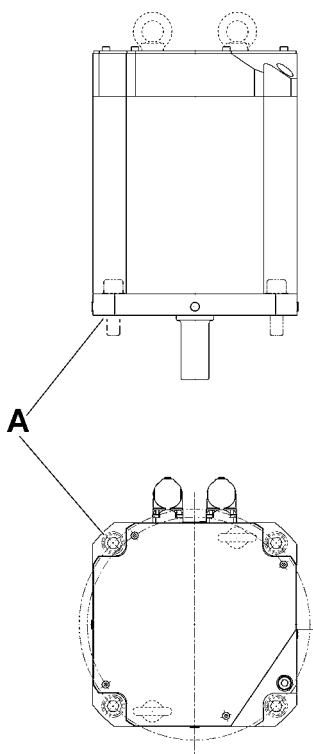

- Smear threadlocker (e.g. Loctite[®] 243) onto the fastening screws.
- Fasten the motor to the machine with the fastening screws through the through-holes (A).
 - ① Mount the motor in such a way that the identification plate remains legible.
 - ① Only use washers for motors that have an aluminum flange.
 - ① The prescribed screws and tightening torques can be found in Chapter 10.1.1 "Specifications for mounting to a machine (MRS)", Table "TbI-16".

5.2.2 Attaching TPM⁺ motor to a machine

- Observe the safety and processing instructions for the threadlocker to be used.

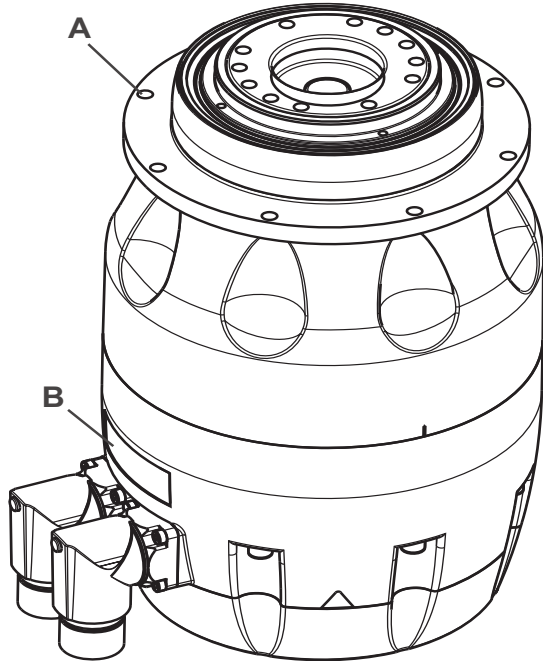

- Smear the fastening screws with a threadlocker (e.g. Loctite[®] 243).
- Fasten the TPM⁺ on the machine with the fastening screws through the through-holes (A).
 - ① Mount the TPM⁺ in such a way that the type plate (B) remains legible.
 - ① Do not use washers (e.g. plain washers, tooth lock washers).
 - ① The prescribed screw sizes and tightening torques can be found in Chapter 10.1.2 "Specifications for mounting onto a machine (TPM+)", Table "Tbl-17".

5.2.3 Attaching ARS motor to a machine

- Observe the safety and processing instructions for the threadlocker to be used.

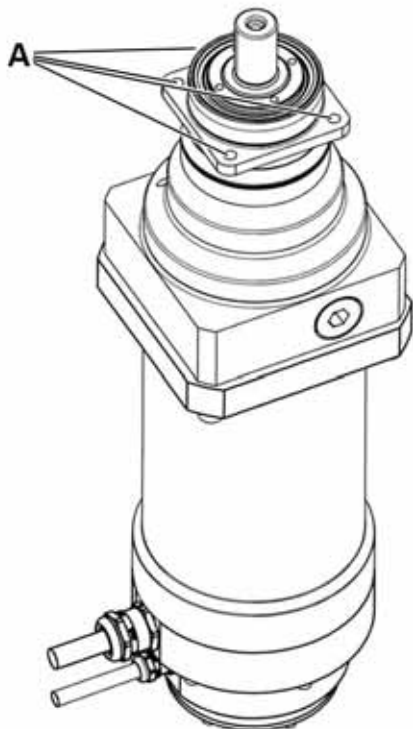

- Smear the fastening screws with a threadlocker (e.g. Loctite[®] 243).
- Fasten the ARS on the machine with the fastening screws through the through-holes (A).
 - ① Mount the ARS in such a way that the identification plate remains legible.
 - ① Do not use washers (e.g. plain washers, tooth lock washers).
 - ① The prescribed screw sizes and tightening torques can be found in Chapter 10.1.3 "Specifications for mounting onto a machine (ARS)", Table "Tbl-19".

5.3 Components mounted to the output side

	NOTICE
	<p>Tensions during the assembly may damage the motor.</p> <ul style="list-style-type: none"> ● Mount gearwheels and toothed belt pulleys onto the output shaft / output flange without forcing. ● Never attempt to assemble by force or hammering! ● Screw in the screws only up to their maximum depth. ● Only use suitable tools and devices for assembly. ● Make sure not to exceed the maximum permissible static axial forces on the output bearing when pulling or shrink-fitting a gear onto the output shaft.

Information for mounting on the output flange (TPM) can be found in Chapter 10.1.2 "Specifications for mounting onto a machine (TPM+)", Table "Tbl-18".





For additional information, please contact our Sales department. Always state the serial number when doing so.

5.4 Installing the electrical connections

	<ul style="list-style-type: none"> ● Make sure that the maximum power length of the power-carrying connecting cable between motor and power electronics does not exceed 75m.
--	---

	⚠ DANGER
	<p>Electrically live components may result in electric shocks if touched and can cause serious injuries and even death.</p> <ul style="list-style-type: none"> ● Observe the five safety rules of electrical engineering before starting electrical installation work: <ul style="list-style-type: none"> - Disconnect. - Secure against being switched on again. - Check that there is no voltage. - Ground and short-circuit. - Cover neighboring and electrified parts. ● Before switching the voltage back on, check that all electrified parts are equipped with suitable and undamaged contact protection. ● Check that protective caps are on the plugs. If protective caps are missing, check the plugs for damage and soiling.

	⚠ DANGER
	<p>Electric operation in moist areas may result in electric shocks and can cause serious injuries and even death.</p> <ul style="list-style-type: none"> ● Carry out the electrical assembly only in dry areas.

	<p style="text-align: center;">⚠ DANGER</p> <p>Excessively high contact voltages may cause electrical shock, which may lead to serious injuries and even death.</p> <ul style="list-style-type: none"> • Avoid excessively high contact voltages (e.g. in the event of damage to the insulation) by providing all exposed and electrically live parts with a protective earth. • Connect the terminal provided at the motor (e.g. direct PE conductor, grounding terminal, ground pin in the motor connector) with the relevant counterpart in the system ground. • For protective earth, use a conductor cross-section that is at least equal to the motor's power supply cable, unless otherwise provided in applicable regulation.
	<p style="text-align: center;">⚠ DANGER</p> <p>Not connecting the earth conductor may lead to electrostatic discharges which can lead to explosions. Explosions can cause serious injuries and even death.</p> <ul style="list-style-type: none"> • Ensure that the earth conductor is properly connected.
	<p style="text-align: center;">⚠ DANGER</p> <p>Faulty electrical connections or unapproved, current-carrying components can lead to explosions that can cause serious injuries and even death.</p> <ul style="list-style-type: none"> • Have all electrical connection work performed by qualified technicians only. • Use only converters that meet the requirements in Chapter 6.2.1 "Operation with PWM converter". • Use an approved and certified terminal box inside areas with explosion hazard.
	<p style="text-align: center;">NOTICE</p> <p>The cable and the line infeeds (cable screw connections) are not designed for traction forces or bending torques.</p> <ul style="list-style-type: none"> • Make sure there is a proper clamp connection of the cable so that the cable and line infeeds are not subjected to any forces. • Lay the cable in a straight line from the cable and line infeed.

5.4.1 Motors with flying lead

	NOTICE
	<ul style="list-style-type: none"> For drives with a flying lead, the cable must be connected to a housing that conforms to the requirements of a recognized ignition protection according to EN 60079-0 if the connection is to be made in an area with explosion hazards.

	NOTICE
	<p>The cables are not designed for traction forces or bending torques.</p> <ul style="list-style-type: none"> The cables must be laid in such a way that the minimum bending radius is no more than 10 x the outer diameter. The power cable may be twisted by no more than $\pm 180^\circ$ over a length of 0.6 m. The signal cable may be twisted by no more than $\pm 30^\circ$ over a length of 1 m.

5.4.2 Motors with internal terminal strip

	DANGER
	<p>The area where the cover sits on the motor housing constitutes an ignition gap. Damage to these surfaces voids the explosion protection of the motor and leads to explosions that cause serious injuries and even death.</p> <ul style="list-style-type: none"> Ensure that these areas on the cover and on the motor housing do not become soiled or damaged!

- Open the cover of the motor by removing the cover screws. Make sure not to lose, damage or soil the O-ring.
- Insert the cables into the motor through the respective cable screw connections. Observe the differing diameters of the cables (see Table "Tbl-6") and the cable screw connection, if applicable. For correct positioning, refer to customer drawing (5007-...).

	NOTICE
	<p>It is prohibited to make the cable fit the cable screw connection by using sealing tape, shrink tubes or other materials.</p>

The cables to be used must meet the requirements of EN 60079-14 Section 9 and also have the following properties:

	Power cable	Signal cable
Conductor material	Copper	Copper
Shape	round and compact	round and compact
Outer diameter:		
MRSH064A-105C...	10 to 14 mm	7 to 12 mm
MRSH155A-165C...	9 to 16 mm	7 to 12 mm
Temperature range	-20° C to 140° C	-20° C to 140° C

	Power cable	Signal cable
Wire count and mm² per conductor		
MRSH064A-105C...	4 x 1.5	10 x 0.5 (twisted pairs)
MRSH155A-165C...	4 x 2.5 + 2 x 1.5	12 x 0.5 (twisted pairs)
Color coding	see signal list (5085-...)	see signal list (5085-...)
Shielding	tin-coated Cu wires 85% covering	tin-coated Cu wires 75% covering
Nominal voltage	500 V	300 / 500 V
Test voltage	2000 V	1000 V

Tbl-6: Cable properties

- ① Also observe the specifications in EN 60079-14 regarding the hazards of electrostatic charges in cables.
- Connect the cables to the terminal strip according to the signal list (5085-...).
- Smear the fastening screws of the cover with a threadlocker (e.g. Loctite® 243).
- **For MRSH064A-105C...:** Tighten the clamping nut of the cable screw connection by hand until resistance can be felt (until the integrated seal is in contact with the cable). Afterwards, further tighten the clamping nut with a spanner by one full turn.
For MRSH155A-165C...: Tighten the cap nut of the cable screw connection using a torque wrench with a tightening torque of 10 Nm.

	⚠ DANGER
	<p>A missing, damaged or soiled O-ring voids the explosion protection of the motor. Explosions can cause serious injuries and even death.</p> <ul style="list-style-type: none"> ● Before removing the cover, check that the O-ring is properly seated in the groove and is not damaged or soiled.

- Close the cover by tightening the fastening screws. The required tightening torque can be found in Chapter 10.2 "Tightening torques for common thread sizes in general mechanical engineering", Table "Tbl-20".

	<p>To guarantee explosion protection, it is necessary that all intended screws are present in the cover and have been tightened with the respective tightening torque!</p>
---	---

5.4.3 Motors with external earth conductor connection

For motors with external earth conductor connection, the earth conductor is connected via the ground terminal on the motor housing.

	⚠ DANGER
	<p>Not connecting the earth conductor may lead to electrostatic discharges which can lead to explosions. Explosions can cause serious injuries and even death.</p> <ul style="list-style-type: none"> • Ensure that the earth conductor is properly connected.

The earth conductor to be connected must be labelled in accordance with IEC 60445 and have the following properties:

Conductor material	Copper
Minimum cross-section, finely stranded	4.0 mm ²
Minimum cross-section, single strand	6.0 mm ²

Tbl-7: Earth conductor properties

- Loosen the screw of the ground terminal.
 - ① It is not necessary to fully unscrew and remove the screw.
- Push the PE conductor under the clamp.
- Tighten the screws with a tightening torque of 2.0 Nm.

6 Startup and operation

6.1 Safety information and environmental conditions

- Read the general safety instructions before beginning work (see Chapter 2.7 "General safety instructions").

	⚠ DANGER
	<p>Missing, loose or damaged screws in the motor housing void the explosion protection of the motor. Explosions can cause serious injuries and even death.</p> <ul style="list-style-type: none"> • Before startup, ensure that all screws have been screwed in.

- Measure the insulation resistance of the motor prior to startup.
 - ① The insulation resistance has to be at least 50 MΩ when new and at least 20 MΩ after being used!
- For motors with greased bearing (standard version): If the motor is not used for a period of > 1 year, it is recommended to let the motor bearings run for grease distribution. To do so, let the motor run at 50% of its nominal speed for 60s each in both directions of rotation.
- If the motor is equipped with a holding brake, ensure that the instructions in Chapter 6.1.5 "Holding brake" are observed.

	<p>Improper use can cause damage to the motor.</p> <ul style="list-style-type: none"> • Ensure that the limit values in the following sub-chapters are observed. • If this requirement cannot be fulfilled, please contact our sales department. Always state the serial number when doing so. • Only operate the motor when it is firmly mounted.
--	--

6.1.1 Humidity / Temperature

For continuous operation of motors, the limit values are valid according to the classification 3K4 acc. to DIN EN 60721-3-3:1995, Table 1 (see Table "Tbl-8").

Temperature range	Relative humidity	Absolute humidity	Temperature change speed
see specifications given on the identification plate ^a	5 ... 95%	1 ... 29 g/m ³	0.5 °C/min
^a extended in comparison to standard value			

Tbl-8: Limit values for temperature and humidity

6.1.2 Vibration

For sinusoidal vibrations at a stationary place of use, the limit value is applicable in compliance with DIN EN 60721-3-3:1995 and DIN EN 60068-2-6:2007.

Maximum permissible vibration load (55–2000Hz)
10 m/s ²

Tbl-9: Limit value for vibration load

6.1.3 Shock

For the maximum permissible shock load (brief acceleration), the limit values are valid in compliance with DIN EN 60721-3-3:1995 and DIN EN 60068-2-27:2009.

Direction	Maximum permissible shock load (11 ms)
axial	10 m/s ²
radial	150 m/s ²

Tbl-10: Limit values for shock load

6.1.4 Chemical resistance

Before startup, determine the chemical resistance of the motor against possible residual fluids/gases in order to avoid premature failure.

6.1.5 Holding brake

The following instructions apply exclusively to **electrical** holding brakes.

- If the motor is equipped with a holding brake, ensure that this brake is vented during startup, and that the motor is never operated with the brake applied.
 - ① The brake is applied in a currentless state. Control of the brake is performed by the customer using the regulating device. Technical data on the brake can be found on the identification plate, in the technical documentation (5098-...) as well as the signal list (5085-...).
 - ① A holding brake is no safety brake, as defined by DIN EN 13849-1 or by the German BGHM regarding hanging axes (only available in German), and is therefore not intended to be used as a brake for the protection of persons or as a dynamic brake.

The brake may not be used

- to prevent the counter-rotation in case of a counter-current braking,
- as a safety against a faultily set rotational direction,
- as emergency stop.

Running in the holding brake

The holding brake may no longer reach the specified holding torque M_4 due to the effects of storage, conditions or type of use, overvoltage or high temperature, combined with ambient conditions (soiling, humidity, etc.).

- To restore the holding power, perform the run-in procedure described by the brake manufacturer.
 - Apply the brake briefly for a defined time (at the specified speed of the motor and for a defined number of runs) and then release it again.
 - Or, drive the motor against the applied brake for a defined number of revolutions at a specified speed.
- ① For additional information and for correct data on the grinding-in process, contact our sales department. Always provide the ordering code and serial number.

Commissioning the holding brake

To make sure the holding brake is functioning, it has to be tested during startup.

- If the regulating device has a function for integrated testing of the holding torque during secure limited movement and secure limited speed, then use this function and observe the instructions from the regulating device's manufacturer.

If no such function is present, we recommend that the user proceeds as follows:

- Limit the permitted range of movement and the maximum speed using the parameters in the regulating device so that no danger to persons or property can arise from movement of the axle.
- Calculate the power of the motor I_{M4} required to achieve the holding torque M_4 with the torque constant, and limit the maximum current of the regulating device to this value.
- Apply current to the motor with the holding brake applied, gradually increasing the current to I_{M4} . During this, the motor must not move. Observe the permitted time for applying current of I_{M4} to the motor.
- If movement does occur, the user should ideally switch off the current supply automatically to avoid uncontrolled movement of the axle.
- If the holding torque M_4 is not reached, perform the grinding-in process described by the brake manufacturer.
- After the grinding-in process check again the holding torque M_4 .

If the holding torque M_4 specified in the brake's technical data is reached, then the holding brake is ready for operation.

If the holding torque M_4 specified in the brake's technical data is **not** reached then:

- Repeat the grinding-in procedure.
 - ① The grinding-in process may only be repeated twice during a testing procedure for the holding torque M_4 .

If the holding torque M_4 is not reached after the third grinding-in process then the holding brake is **not functioning properly**:

- Do **not** start up the drive. Contact our sales department.
 - ① Always provide the ordering code and serial number.

Testing the holding brake regularly

To ensure the permanent functioning of the holding brake, it has to be regularly applied and checked.

- It is recommended that the holding brake is released and applied at least twice daily by deactivating the controller.
- It is recommended that the holding torque M_4 of the brake is checked at least once a day.

Provisional run-in data

Use of the following data is recommended if no data is available for the motor regarding the run-in process:

- Within 24 h **of the first startup**, grind in the brake as follows:
 - The brake is applied
 - At a speed of 100 min^{-1}
 - Once for 5 revolutions
 - Ambient temperature between $0 \text{ }^\circ\text{C}$ and $+40 \text{ }^\circ\text{C}$
- Grind in the brake **after startup** as follows:
 - Apply and release every 500 ms
 - At a speed of 100 min^{-1}
 - For a duration of 30 s
 - Ambient temperature between $0 \text{ }^\circ\text{C}$ and $+40 \text{ }^\circ\text{C}$

6.1.6 Check running-in behavior (for ARS and TPM⁺ only)

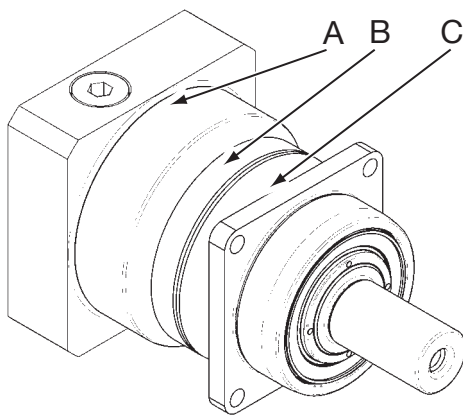

- After 4 running hours in maximum operating conditions, check the motor for leakage between gear and motor and on the output shaft seal.
- Measure the surface temperature on the input flange (A) and on the housing (B) and bearing flange (C). Consult our Customer Service department if the surface temperature exceeds +90 °C.

6.2 Operation

The thermal expansion of the motor shaft and the housing was taken into account in design of the motor.

- ① If the following requirements cannot be fulfilled, please contact our sales department. Always state the serial number when doing so.

Circumferential radial forces and tilting moments on the shaft are not permitted for motors of the MRS series. The following applies to motors of the ARS and TPM series:

	Max. radial force [N]*	Max. tilting moment [Nm]
ARSQ064A-030C-4D5DF-EI0GEG-NNN	500	–
TPM010F-016K-6PB1-094C-W4	–	270
TPM050F-016K-6PB1-130D-W4	–	1335
* based on the shaft or flange center at the gear output		

Tbl-11: Radial force and tilting moment for ARS and TPM series

It is permissible that the maximum tilting moment and maximum radial force occur simultaneously. Use the motor only up to its maximum limit values, see Chapter 3.4 "Performance data".

- ① Inadmissibly high voltage gradient can lead to early failure of the insulation system at the motor winding.

Unless agreed otherwise, a limit of no more than 8kV/μs applies for the voltage gradient of the pulsed voltage at the power connections of the motor.

- In case of doubt, please contact the supplier of your power electronics.

The motor is balanced so that the limit values in Table "Tbl-12" are not exceeded for rigid clamping.

Clamping	Displacement [μm]	Speed [mm/s]	Acceleration [m/s ²]
Rigid	21	1.3	2

Tbl-12: Limits vibration level A (RMS)

- If the limits are exceeded, look for the cause by checking the following possibilities, among others:
 - Unsuitable foundation
 - Natural frequency of the driven load machine
 - Nonconforming setting of the current and speed regulator
- Take appropriate corrective measures to ensure the service life of the motor.

6.2.1 Operation with PWM converter





The motors are designed for power supply with a PWM converter. Some motors have been certified in conjunction with a specific converter and may only be operated with this converter. The specific designation of the converter to be used is given on the identification plate of the affected motors.

① You can also find this information in Table "Tbl-13".

Motor designation	Designation of the converter
TPM010F-016K-6PB1-094C-W4	Bosch Rexroth HCS02.1E-W0028-A-03
TPM050F-016K-6PB1-130D-W4	Bosch Rexroth HCS02.1E-W0054-A-03
MRSR064A-030C-4D5DF-EI0GEG-NNN	Kollmorgen Servostar 303
ARSQ064A-030C-4D5DF-EI0GEG-NNN	Kollmorgen Servostar 303

Tbl-13: Prescribed PWM converters

The motors are monitored for impermissible warming due to overloading by a triple thermistor that must be connected to a functionally-tested triggering device. As an option, some motors are equipped with an additional temperature sensor that must be connected to the respective evaluation unit of the converter. In addition, the following values must be set at the converter and adhered to during operation:

Commutation type	Sine
Minimum frequency	8 kHz*
Maximum frequency	16 kHz*
 Temporary current limit	I_{\max}
Maximum overload time	10 s
 Current limit	I_0
 Maximum voltage at converter input	$U_{DC} / \sqrt{2}$
 Maximum intermediate circuit voltage	U_{DC}
Minimum speed	0 rpm
 Maximum speed (both rotational directions)	n_0 or $n_{\text{limit,max}}$

Tbl-14: General properties of the PWM converter

*The MRS1155A-165C-3V5SF-FM1GEW-NNN motor must be operated with a frequency of 4kHz.

The values for I_0 , I_{\max} , U_{DC} and n_0 as well as the permissible torques can be found in the performance data in Chapter 3.4. Mains voltage fluctuations of up to $\pm 10\%$ and mains frequency fluctuations of up to $\pm 3\%$ are permissible, corresponding to area B of IEC 60034-1.

Operation of the motor in field weakening is only permitted when an explicit approval of this is indicated in the motor speed and torque characteristics (5012-...).

① If these requirements cannot be fulfilled, please contact our sales department. Always state the serial number when doing so.



If the maximum current of the selected converter is greater than the maximum current of the motor, then the power circuit between converter and motor must be secured 3-phased with slow-blow fuses. Based on the maximum current of the motor (I_{\max}), the next higher value must be selected as the rated current for the slow-blow fuse.

7 Maintenance, repairs and disposal

- Read the general safety instructions before beginning work (see Chapter 2.7 "General safety instructions").
- Unless explicitly agreed otherwise for customer-specific motors, perform maintenance, repairs and disposal according to the following sections.

7.1 Maintenance work

7.1.1 Cleaning

	NOTICE
	<p>To prevent creating an explosive atmosphere by stirring up dust deposits, any dust deposits on the motors must be removed by regular cleaning.</p>

The motor may not come into contact with the solvents hexane and toluene, because they impair the adhesion of the identification plates.

7.1.2 Checking the holding brake

The motor can be optionally equipped with a holding brake.

To ensure the permanent functioning of the holding brake, it has to be regularly applied and checked.

- It is recommended that the holding brake is released and applied at least twice daily by deactivating the controller.
- It is recommended that the holding torque M_4 of the brake is checked at least once a day.

① Details can be found in chapter 6.1.5 "Holding brake".

7.1.3 Visual inspection

Perform a **monthly** visual inspection:

- Check the motor, moving cables and the shaft sealing ring for damage.
- Check whether the cable ends are completely labeled.
- Remove any dust deposits.
- **ARS/TPM⁺**: Check the motor for leaking lubricant.

7.1.4 Checking for leakage (ARS only)

Check the motor every **three months** for leakages:

- Check the gear output radial shaft seal for leakage.

	⚠ DANGER
	<p>When opening up the Ermeto coupling, dust could collect on the adapter plate and catch fire during later operation.</p> <ul style="list-style-type: none"> • Ensure that no explosive dust-air mixture is present and no dust can get into the adapter plate before opening the Ermeto coupling or removing the gearhead from the motor.

- Look for external emission of lubricant from the drive.
- Open up the Ermeto screw connection in the adapter plate and check for any lubricant leakage inside the adapter plate.
- If a leak is detected, remove the lubricant and re-check the inside of the adapter plate after brief operation. Lubricant discharge should stop after a short time.
- In case lubricant is still leaking, shut down the motor and consult our Customer Service.

7.1.5 Inspection

Due to aging of the bearing grease and seal materials, it is necessary to send in the motor for inspection to **WITTENSTEIN cyber motor GmbH** after every **20,000 operating hours**, or at least every **6 years**.

- ① **For the TPM motor...** the gearhead also needs to be replaced **after every 10,000 operating hours**. To have this carried out, send the motor to **WITTENSTEIN cyber motor GmbH**.
- ① **For the ARS motor...** in addition to the inspection after 20,000 operating hours, the grease-lubricated gearhead must be replaced **after every 30,000 operating hours**. To have this carried out, send the motor to **WITTENSTEIN cyber motor GmbH**. If requested, **WITTENSTEIN cyber motor GmbH** will also replace the gearhead after 20,000 operating hours.

7.2 Start-up after maintenance work

- Attach all safety devices.

7.3 Note on repairs



Only **WITTENSTEIN cyber motor GmbH** is authorized to perform **repair work** on the motor.

7.3.1 Repainting

	⚠ WARNING
<p>Paint layers that are too thick may lead to electrostatic discharge. There is a risk of explosion.</p> <ul style="list-style-type: none"> ● Under no circumstances carry out any repainting work / paint repairs yourself. ● Hand the motor over to WITTENSTEIN cyber motor GmbH for paint work. 	

7.4 Disposal

- Dispose of the motor at the recycling sites intended for this purpose.
- Observe the applicable national regulations concerning disposal.

8 Malfunctions

Fault	Possible cause	Solution
NOTICE		
 <p>Changed operational behavior can be an indication of existing damage to the motor or cause damage to the motor.</p> <ul style="list-style-type: none"> Do not put the motor back into operation until the cause of the malfunction has been rectified. 		
Motor does not start	Incorrectly connected	Check the connections using the signal list
	Parameter set does not correspond to motor	Check the motor data record in the power electronics
Increased operating temperature	Motor is heavily soiled	Clean the outside of the motor
	Motor is not suited for the task	Check the technical specifications
	Ambient temperature too high/low air pressure due to altitude	Ensure adequate cooling.
	Motor becomes very hot / encoder set incorrectly	Check the power electronics of the motor and the power supply or consult our Customer Service department.
Increased operating noises	Damaged bearings	Consult our Customer Service department.
	Damaged gear teeth	
Sporadic failure	Damaged cable	Consult our Customer Service department.
Loss of lubricant	Lubricant quantity too high	Wipe off discharged lubricant and continue to watch the gearhead. Lubricant discharge should stop after a short time.
	Seals not tight	Consult our Customer Service department.
Clamp connection is slipping	Clamping bolt not tightened properly	Check the shaft seat and hub bore for damages. Check the screw for proper tightening torque and secure it against loosening by itself.
	Operating parameters not maintained	Check the operating parameters.
Metal bellows of the coupling broken	Operating parameters do not meet the requirements	Consult our Customer Service department.
	Operating error of the system unit	

Tbl-15: Malfunctions

9 Declarations of conformity

9.1 Declaration of conformity MRSR064A-030C-4D5DF-EI0GEG-NNN



EU-Konformitätserklärung EU Declaration of Conformity

Wir / We
Anschritt / Adress

WITTENSTEIN cyber motor GmbH
Walter-Wittenstein-Straße 1
D-97999 Igersheim / Germany
Tel: +49(0)7931 - 493-15800
Fax: +49(0)7931 - 493-10905
E-mail: info@wittenstein-cyber-motor.de

erklären hiermit in alleiniger Verantwortung, dass das Erzeugnis / *declare under our sole responsibility, that the product*
Bezeichnung / Designation

MN 50013944-00-0

Typ / Type

MRSR064A-030C-4D5DF-EI0GEG-NNN

konform ist zu den EU-Richtlinien / 2011/65/EU	<i>is conform with the EU directives</i> Beschränkung der Verwendung bestimmter gefährlicher Stoffe in Elektro- und Elektronikgeräten (RoHS-Richtlinie) <i>Restriction of the use of certain hazardous substances in electrical and electronic equipment (RoHS directive)</i>
2014/34/EU	Geräte und Schutzsysteme zur bestimmungsgemäßen Verwendung in explosionsgefährdeten Bereichen (ATEX-Richtlinie) <i>Equipment and protective systems intended for use in potentially explosive atmospheres (ATEX directive)</i>

und die einschlägigen Bestimmungen dieser EU-Richtlinien erfüllt. / *and fulfills the relevant provisions of these EU directives.*
Das Erzeugnis erfüllt die den wesentlichen Anforderungen der oben genannten EU-Richtlinien entsprechenden Bestimmungen der harmonisierten Normen / *The product fulfills the essential requirements of the EU directives mentioned above by fulfilling the corresponding requirements of the harmonized standards*

EN 60079-0:2018	Explosionsgefährdete Bereiche - Teil 0: Betriebsmittel - Allgemeine Anforderungen <i>Explosive atmospheres - Part 0: Equipment - General requirements</i>
EN 60079-1:2014/AC:2018-09	Explosionsgefährdete Bereiche - Teil 1: Geräteschutz durch druckfeste Kapselung "d" <i>Explosive atmospheres - Part 1: Equipment protection by flameproof enclosures "d"</i>
EN 60079-7:2015 + A1:2018	Explosionsgefährdete Bereiche - Teil 7: Geräteschutz durch erhöhte Sicherheit "e" <i>Explosive atmospheres - Part 7: Equipment protection by increased safety "e"</i>
EN 60079-31:2014	Explosionsgefährdete Bereiche - Teil 31: Geräte-Staubexplosionsschutz durch Gehäuse "t" <i>Explosive atmospheres - Part 31: Equipment dust ignition protection by enclosure "t"</i>
EN 1127-1:2011	Explosionsfähige Atmosphären - Explosionsschutz - Teil 1: Grundlagen und Methodik <i>Explosive atmospheres - Explosion prevention and protection - Part 1: Basic concepts and methodology</i>

Das Erzeugnis trägt das CE-Zeichen. / *The product bears the CE-marking.*

5055-D044615-03

Igersheim, den 22.03.2021
Ort und Datum der Ausstellung / Place
and date of declaration

Dr. Ingolf Gröning
Geschäftsführer / General Manager
WITTENSTEIN cyber motor GmbH

9.2 Declaration of conformity MRSH064A-105C-6D0DF-RA0PEW-NNN



EU-Konformitätserklärung

EU Declaration of Conformity

Wir / We
Anschrift / Adress

WITTENSTEIN cyber motor GmbH
Walter-Wittenstein-Straße 1
D-97999 Igersheim / Germany
Tel: +49(0)7931 - 493-15800
Fax: +49(0)7931 - 493-10905
E-mail: info@wittenstein-cyber-motor.de

erklären hiermit in alleiniger Verantwortung, dass das Erzeugnis / *declare under our sole responsibility, that the product*
Bezeichnung / Designation

MN 50014893-01-0

Typ / Type

MRSH064A-105C-6D0DF-RA0PEW-NNN

konform ist zu den EU-Richtlinien / 2011/65/EU	<i>is conform with the EU directives</i> Beschränkung der Verwendung bestimmter gefährlicher Stoffe in Elektro- und Elektronikgeräten (RoHS-Richtlinie) <i>Restriction of the use of certain hazardous substances in electrical and electronic equipment (RoHS directive)</i>
2014/34/EU	Geräte und Schutzsysteme zur bestimmungsgemäßen Verwendung in explosionsgefährdeten Bereichen (ATEX-Richtlinie) <i>Equipment and protective systems intended for use in potentially explosive atmospheres (ATEX directive)</i>

und die einschlägigen Bestimmungen dieser EU-Richtlinien erfüllt. / *and fulfills the relevant provisions of these EU directives.*
Das Erzeugnis erfüllt die den wesentlichen Anforderungen der oben genannten EU-Richtlinien entsprechenden Bestimmungen der harmonisierten Normen / *The product fulfills the essential requirements of the EU directives mentioned above by fulfilling the corresponding requirements of the harmonized standards*

EN 60079-0:2018	Explosionsgefährdete Bereiche - Teil 0: Betriebsmittel - Allgemeine Anforderungen <i>Explosive atmospheres - Part 0: Equipment - General requirements</i>
EN 60079-1:2014/AC:2018-09	Explosionsgefährdete Bereiche - Teil 1: Geräteschutz durch druckfeste Kapselung "d" <i>Explosive atmospheres - Part 1: Equipment protection by flameproof enclosures "d"</i>
EN 60079-31:2014	Explosionsgefährdete Bereiche - Teil 31: Geräte-Staubexplosionsschutz durch Gehäuse "t" <i>Explosive atmospheres - Part 31: Equipment dust ignition protection by enclosure "t"</i>
EN 1127-1:2011	Explosionsfähige Atmosphären - Explosionsschutz - Teil 1: Grundlagen und Methodik <i>Explosive atmospheres - Explosion prevention and protection - Part 1: Basic concepts and methodology</i>

Das Erzeugnis trägt das CE-Zeichen. / *The product bears the CE-marking.*

5055-D004862-03

Igersheim, den 22.03.2021
Ort und Datum der Ausstellung / Place
and date of declaration

Dr. Ingolf Gröning
Geschäftsführer / General Manager
WITTENSTEIN cyber motor GmbH

9.3 Declaration of conformity MRSH064A-105C-6D3DF-RA0PEW-NNN



EU-Konformitätserklärung

EU Declaration of Conformity

Wir / We
Anschrift / Adress

WITTENSTEIN cyber motor GmbH
Walter-Wittenstein-Straße 1
D-97999 Igersheim / Germany
Tel: +49(0)7931 - 493-15800
Fax: +49(0)7931 - 493-10905
E-mail: info@wittenstein-cyber-motor.de

erklären hiermit in alleiniger Verantwortung, dass das Erzeugnis / *declare under our sole responsibility, that the product*
Bezeichnung / Designation

MN 50020716-00-0

Typ / Type

MRSH064A-105C-6D3DF-RA0PEW-NNN

konform ist zu den EU-Richtlinien / 2011/65/EU	<i>is conform with the EU directives</i> Beschränkung der Verwendung bestimmter gefährlicher Stoffe in Elektro- und Elektronikgeräten (RoHS-Richtlinie) <i>Restriction of the use of certain hazardous substances in electrical and electronic equipment (RoHS directive)</i>
2014/34/EU	Geräte und Schutzsysteme zur bestimmungsgemäßen Verwendung in explosionsgefährdeten Bereichen (ATEX-Richtlinie) <i>Equipment and protective systems intended for use in potentially explosive atmospheres (ATEX directive)</i>

und die einschlägigen Bestimmungen dieser EU-Richtlinien erfüllt. / *and fulfills the relevant provisions of these EU directives.*
Das Erzeugnis erfüllt die den wesentlichen Anforderungen der oben genannten EU-Richtlinien entsprechenden Bestimmungen der harmonisierten Normen / *The product fulfills the essential requirements of the EU directives mentioned above by fulfilling the corresponding requirements of the harmonized standards*

EN 60079-0:2018	Explosionsgefährdete Bereiche - Teil 0: Betriebsmittel - Allgemeine Anforderungen <i>Explosive atmospheres - Part 0: Equipment - General requirements</i>
EN 60079-1:2014/AC:2018-09	Explosionsgefährdete Bereiche - Teil 1: Geräteschutz durch druckfeste Kapselung "d" <i>Explosive atmospheres - Part 1: Equipment protection by flameproof enclosures "d"</i>
EN 60079-31:2014	Explosionsgefährdete Bereiche - Teil 31: Geräte-Staubexplosionsschutz durch Gehäuse "t" <i>Explosive atmospheres - Part 31: Equipment dust ignition protection by enclosure "t"</i>
EN 1127-1:2011	Explosionsfähige Atmosphären - Explosionsschutz - Teil 1: Grundlagen und Methodik <i>Explosive atmospheres - Explosion prevention and protection - Part 1: Basic concepts and methodology</i>

Das Erzeugnis trägt das CE-Zeichen. / *The product bears the CE-marking.*

5055-D059029-02

Igersheim, den 22.03.2021
Ort und Datum der Ausstellung / Place
and date of declaration

Dr. Ingolf Gröning
Geschäftsführer / General Manager
WITTENSTEIN cyber motor GmbH

9.4 Declaration of conformity MRSH064A-105C-9D7SF-RA0PEW-NNN



EU-Konformitätserklärung

EU Declaration of Conformity

Wir / We
Anschrift / Address

WITTENSTEIN cyber motor GmbH
Walter-Wittenstein-Straße 1
D-97999 Igersheim / Germany
Tel: +49(0)7931 - 493-15800
Fax: +49(0)7931 - 493-10905
E-mail: info@wittenstein-cyber-motor.de

erklären hiermit in alleiniger Verantwortung, dass das Erzeugnis / *declare under our sole responsibility, that the product*

Bezeichnung / Designation

MN 50014892-01-0

Typ / Type

MRSH064A-105C-9D7SF-RA0PEW-NNN

konform ist zu den EU-Richtlinien / *is conform with the EU directives*

2011/65/EU

Beschränkung der Verwendung bestimmter gefährlicher Stoffe in Elektro- und Elektronikgeräten (RoHS-Richtlinie)
Restriction of the use of certain hazardous substances in electrical and electronic equipment (RoHS directive)

2014/34/EU

Geräte und Schutzsysteme zur bestimmungsgemäßen Verwendung in explosionsgefährdeten Bereichen (ATEX-Richtlinie)
Equipment and protective systems intended for use in potentially explosive atmospheres (ATEX directive)

und die einschlägigen Bestimmungen dieser EU-Richtlinien erfüllt. / *and fulfills the relevant provisions of these EU directives.*

Das Erzeugnis erfüllt die den wesentlichen Anforderungen der oben genannten EU-Richtlinien entsprechenden Bestimmungen der harmonisierten Normen / *The product fulfills the essential requirements of the EU directives mentioned above by fulfilling the corresponding requirements of the harmonized standards*

EN 60079-0:2018

Explosionsgefährdete Bereiche - Teil 0: Betriebsmittel - Allgemeine Anforderungen
Explosive atmospheres - Part 0: Equipment - General requirements

EN 60079-1:2014/AC:2018-09

Explosionsgefährdete Bereiche - Teil 1: Geräteschutz durch druckfeste Kapselung "d"
Explosive atmospheres - Part 1: Equipment protection by flameproof enclosures "d"

EN 60079-31:2014

Explosionsgefährdete Bereiche - Teil 31: Geräte-Staubexplosionsschutz durch Gehäuse "t"
Explosive atmospheres - Part 31: Equipment dust ignition protection by enclosure "t"

EN 1127-1:2011

Explosionsfähige Atmosphären - Explosionsschutz - Teil 1: Grundlagen und Methodik
Explosive atmospheres - Explosion prevention and protection - Part 1: Basic concepts and methodology

Das Erzeugnis trägt das CE-Zeichen. /

The product bears the CE-marking.

5055-0044861-03

Igersheim, den 18.03.2021
Ort und Datum der Ausstellung / Place
and date of declaration

Dr. Ingolf Gröning
Geschäftsführer / General Manager
WITTENSTEIN cyber motor GmbH

9.5 Declaration of conformity MRSR094A-135C-2V7DF-EI0PEW-NNN



EU-Konformitätserklärung EU Declaration of Conformity

Wir / We
Anschrift / Adress

WITTENSTEIN cyber motor GmbH
Walter-Wittenstein-Straße 1
D-97999 Igersheim / Germany
Tel: +49(0)7931 - 493-15800
Fax: +49(0)7931 - 493-10905
E-mail: info@wittenstein-cyber-motor.de

erklären hiermit in alleiniger Verantwortung, dass das Erzeugnis / *declare under our sole responsibility, that the product*
Bezeichnung / Designation

MN 50010549-00-0

Typ / Type

MRSR094A-135C-2V7DF-EI0PEW-NNN

<p>konform ist zu den EU-Richtlinien / 2011/65/EU</p> <p>2014/34/EU</p>	<p><i>is conform with the EU directives</i></p> <p>Beschränkung der Verwendung bestimmter gefährlicher Stoffe in Elektro- und Elektronikgeräten (RoHS-Richtlinie) <i>Restriction of the use of certain hazardous substances in electrical and electronic equipment (RoHS directive)</i></p> <p>Geräte und Schutzsysteme zur bestimmungsgemäßen Verwendung in explosionsgefährdeten Bereichen (ATEX-Richtlinie) <i>Equipment and protective systems intended for use in potentially explosive atmospheres (ATEX directive)</i></p>
---	---

und die einschlägigen Bestimmungen dieser EU-Richtlinien erfüllt. / *and fulfills the relevant provisions of these EU directives.*
Das Erzeugnis erfüllt die den wesentlichen Anforderungen der oben genannten EU-Richtlinien entsprechenden Bestimmungen der harmonisierten Normen / *The product fulfills the essential requirements of the EU directives mentioned above by fulfilling the corresponding requirements of the harmonized standards*

<p>EN 60079-0:2018</p> <p>EN 60079-1:2014/AC:2018-09</p> <p>EN 60079-31:2014</p> <p>EN 1127-1:2011</p>	<p>Explosionsgefährdete Bereiche - Teil 0: Betriebsmittel - Allgemeine Anforderungen <i>Explosive atmospheres - Part 0: Equipment - General requirements</i></p> <p>Explosionsgefährdete Bereiche - Teil 1: Geräteschutz durch druckfeste Kapselung "d" <i>Explosive atmospheres - Part 1: Equipment protection by flameproof enclosures "d"</i></p> <p>Explosionsgefährdete Bereiche - Teil 31: Geräte-Staubexplosionsschutz durch Gehäuse "t" <i>Explosive atmospheres - Part 31: Equipment dust ignition protection by enclosure "t"</i></p> <p>Explosionsfähige Atmosphären - Explosionsschutz - Teil 1: Grundlagen und Methodik <i>Explosive atmospheres - Explosion prevention and protection - Part 1: Basic concepts and methodology</i></p>
--	--

Das Erzeugnis trägt das CE-Zeichen. / *The product bears the CE-marking.*

5035-0058027-02

Igersheim, den 22.03.2021
Ort und Datum der Ausstellung / Place
and date of declaration

Dr. Ingolf Gröning
Geschäftsführer / General Manager
WITTENSTEIN cyber motor GmbH

9.6 Declaration of conformity MRSH155A-165C-3V5SF-FM1GEW-NNN



EU-Konformitätserklärung EU Declaration of Conformity

Wir / We
Anschrift / Adress

WITTENSTEIN cyber motor GmbH
Walter-Wittenstein-Straße 1
D-97999 Igersheim / Germany
Tel: +49(0)7931 - 493-15800
Fax: +49(0)7931 - 493-10905
E-mail: info@wittenstein-cyber-motor.de

erklären hiermit in alleiniger Verantwortung, dass das Erzeugnis / *declare under our sole responsibility, that the product*
Bezeichnung / Designation

MN 50016627-01-0

Typ / Type

MRSH155A-165C-3V5SF-FM1GEW-NNN

konform ist zu den EU-Richtlinien / 2011/65/EU	<i>is conform with the EU directives</i> Beschränkung der Verwendung bestimmter gefährlicher Stoffe in Elektro- und Elektronikgeräten (RoHS-Richtlinie) <i>Restriction of the use of certain hazardous substances in electrical and electronic equipment (RoHS directive)</i>
2014/34/EU	Geräte und Schutzsysteme zur bestimmungsgemäßen Verwendung in explosionsgefährdeten Bereichen (ATEX-Richtlinie) <i>Equipment and protective systems intended for use in potentially explosive atmospheres (ATEX directive)</i>

und die einschlägigen Bestimmungen dieser EU-Richtlinien erfüllt. / *and fulfills the relevant provisions of these EU directives.*
Das Erzeugnis erfüllt die den wesentlichen Anforderungen der oben genannten EU-Richtlinien entsprechenden Bestimmungen der harmonisierten Normen / *The product fulfills the essential requirements of the EU directives mentioned above by fulfilling the corresponding requirements of the harmonized standards*

EN 60079-0:2018	Explosionsgefährdete Bereiche - Teil 0: Betriebsmittel - Allgemeine Anforderungen <i>Explosive atmospheres - Part 0: Equipment - General requirements</i>
EN 60079-1:2014/AC:2018-09	Explosionsgefährdete Bereiche - Teil 1: Geräteschutz durch druckfeste Kapselung "d" <i>Explosive atmospheres - Part 1: Equipment protection by flameproof enclosures "d"</i>
EN 60079-31:2014	Explosionsgefährdete Bereiche - Teil 31: Geräte-Staubexplosionsschutz durch Gehäuse "t" <i>Explosive atmospheres - Part 31: Equipment dust ignition protection by enclosure "t"</i>
EN 1127-1:2011	Explosionsfähige Atmosphären - Explosionsschutz - Teil 1: Grundlagen und Methodik <i>Explosive atmospheres - Explosion prevention and protection - Part 1: Basic concepts and methodology</i>

Das Erzeugnis trägt das CE-Zeichen. / *The product bears the CE-marking.*

5055-0055575-03

Igersheim, den 22.03.2021
Ort und Datum der Ausstellung / Place
and date of declaration

Dr. Ingolf Gröning
Geschäftsführer / General Manager
WITTENSTEIN cyber motor GmbH

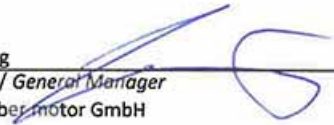

9.7 Declaration of conformity ARSQ064A-030C-4D5DF-EI0GEG-BNN



EU-Konformitätserklärung EU Declaration of Conformity

Wir / We WITTENSTEIN cyber motor GmbH
 Anschrift / Adress Walter-Wittenstein-Straße 1
 D-97999 Igersheim / Germany
 Tel: +49(0)7931 - 493-15800
 Fax: +49(0)7931 - 493-10905
 E-mail: info@wittenstein-cyber-motor.de

erklären hiermit in alleiniger Verantwortung, dass das Erzeugnis / *declare under our sole responsibility, that the product*
 Bezeichnung / Designation

MN 50013945-00-0

Typ / Type

ARSQ064A-030C-4D5DF-EI0GEG-BNN

konform ist zu den EU-Richtlinien / 2011/65/EU	<i>is conform with the EU directives</i> Beschränkung der Verwendung bestimmter gefährlicher Stoffe in Elektro- und Elektronikgeräten (RoHS-Richtlinie) <i>Restriction of the use of certain hazardous substances in electrical and electronic equipment (RoHS directive)</i>
2014/34/EU	Geräte und Schutzsysteme zur bestimmungsgemäßen Verwendung in explosionsgefährdeten Bereichen (ATEX-Richtlinie) <i>Equipment and protective systems intended for use in potentially explosive atmospheres (ATEX directive)</i>

und die einschlägigen Bestimmungen dieser EU-Richtlinien erfüllt. / *and fulfills the relevant provisions of these EU directives.*
 Das Erzeugnis erfüllt die den wesentlichen Anforderungen der oben genannten EU-Richtlinien entsprechenden Bestimmungen der harmonisierten Normen / *The product fulfills the essential requirements of the EU directives mentioned above by fulfilling the corresponding requirements of the harmonized standards*

EN 60079-0:2018	Explosionsgefährdete Bereiche - Teil 0: Betriebsmittel - Allgemeine Anforderungen <i>Explosive atmospheres - Part 0: Equipment - General requirements</i>
EN 60079-1:2014/AC:2018-09	Explosionsgefährdete Bereiche - Teil 1: Geräteschutz durch druckfeste Kapselung "d" <i>Explosive atmospheres - Part 1: Equipment protection by flameproof enclosures "d"</i>
EN 60079-7:2015 + A1:2018	Explosionsgefährdete Bereiche - Teil 7: Geräteschutz durch erhöhte Sicherheit "e" <i>Explosive atmospheres - Part 7: Equipment protection by increased safety "e"</i>
EN 60079-31:2014	Explosionsgefährdete Bereiche - Teil 31: Geräte-Staubexplosionsschutz durch Gehäuse "t" <i>Explosive atmospheres - Part 31: Equipment dust ignition protection by enclosure "t"</i>
EN 1127-1:2011	Explosionsfähige Atmosphären - Explosionsschutz - Teil 1: Grundlagen und Methodik <i>Explosive atmospheres - Explosion prevention and protection - Part 1: Basic concepts and methodology</i>
EN ISO 80079-36:2016	Explosionsfähige Atmosphären - Teil 36: Nicht-elektrische Geräte für den Einsatz in explosionsfähigen Atmosphären - Grundlagen und Anforderungen <i>Explosive atmospheres - Part 36: Non-electrical equipment for explosive atmospheres - Basic method and requirements</i>
EN ISO 80079-37:2016	Explosionsfähige Atmosphären - Teil 37: Nicht-elektrische Geräte für den Einsatz in explosionsfähigen Atmosphären - Schutz durch konstruktive Sicherheit "c", Zündquellenüberwachung "b", Flüssigkeitskapselung "k" <i>Explosive atmospheres - Part 37: Non-electrical equipment for explosive atmospheres - Non-electrical type of protection constructional safety "c", control of ignition sources "b", liquid immersion "k"</i>

Das Erzeugnis trägt das CE-Zeichen. / *The product bears the CE-marking.*

9055-D043534-03

Igersheim, den 22.03.2021
 Ort und Datum der Ausstellung / Place
 and date of declaration

Dr. Ingolf Gröning
 Geschäftsführer / General Manager
 WITTENSTEIN cyber motor GmbH

9.8 Declaration of conformity TPMP010x-016K-6PB1-094C-W4-x01



EU-Konformitätserklärung

EU Declaration of Conformity

Wir / We
Anschrift / Address

WITTENSTEIN cyber motor GmbH
Walter-Wittenstein-Straße 1
D-97999 Igersheim / Germany
Tel: +49(0)7931 - 493-15800
Fax: +49(0)7931 - 493-10905
E-mail: info@wittenstein-cyber-motor.de

erklären hiermit in alleiniger Verantwortung, dass das Erzeugnis / *declare under our sole responsibility, that the product*
Bezeichnung / Designation

MN 50012477

Typ / Type

TPMP010x-016K-6PB1-094C-W4-x01

konform ist zu den EU-Richtlinien / 2011/65/EU	<i>is conform with the EU directives</i> Beschränkung der Verwendung bestimmter gefährlicher Stoffe in Elektro- und Elektronikgeräten (RoHS-Richtlinie) <i>Restriction of the use of certain hazardous substances in electrical and electronic equipment (RoHS directive)</i>
2014/34/EU	Geräte und Schutzsysteme zur bestimmungsgemäßen Verwendung in explosionsgefährdeten Bereichen (ATEX-Richtlinie) <i>Equipment and protective systems intended for use in potentially explosive atmospheres (ATEX directive)</i>

und die einschlägigen Bestimmungen dieser EU-Richtlinien erfüllt. / *and fulfills the relevant provisions of these EU directives.*
Das Erzeugnis erfüllt die den wesentlichen Anforderungen der oben genannten EU-Richtlinien entsprechenden Bestimmungen der harmonisierten Normen / *The product fulfills the essential requirements of the EU directives mentioned above by fulfilling the corresponding requirements of the harmonized standards*

EN 60079-0:2018	Explosionsgefährdete Bereiche - Teil 0: Betriebsmittel - Allgemeine Anforderungen <i>Explosive atmospheres - Part 0: Equipment - General requirements</i>
EN 60079-31:2014	Explosionsgefährdete Bereiche - Teil 31: Geräte-Staubexplosionsschutz durch Gehäuse "t" <i>Explosive atmospheres - Part 31: Equipment dust ignition protection by enclosure "t"</i>
EN 1127-1:2011	Explosionsfähige Atmosphären - Explosionsschutz - Teil 1: Grundlagen und Methodik <i>Explosive atmospheres - Explosion prevention and protection - Part 1: Basic concepts and methodology</i>
EN ISO 80079-36:2016	Explosionsfähige Atmosphären - Teil 36: Nicht-elektrische Geräte für den Einsatz in explosionsfähigen Atmosphären - Grundlagen und Anforderungen <i>Explosive atmospheres - Part 36: Non-electrical equipment for explosive atmospheres - Basic method and requirements</i>

Das Erzeugnis trägt das CE-Zeichen. / *The product bears the CE-marking.*

5055-0039313-05

Igersheim, den 22.03.2021
Ort und Datum der Ausstellung / Place
and date of declaration

Dr. Ingolf Gröning
Geschäftsführer / General Manager
WITTENSTEIN cyber motor GmbH

9.9 Declaration of conformity TPM 050X-016K-6PB1-130D-W4-X01



EU-Konformitätserklärung

EU Declaration of Conformity

Wir / We
Anschrift / Adress
WITTENSTEIN cyber motor GmbH
Walter-Wittenstein-Straße 1
D-97999 Igersheim / Germany
Tel: +49(0)7931 - 493-15800
Fax: +49(0)7931 - 493-10905
E-mail: info@wittenstein-cyber-motor.de

erklären hiermit in alleiniger Verantwortung, dass das Erzeugnis / *declare under our sole responsibility, that the product*
Bezeichnung / Designation

MN 50012478

Typ / Type

TPM 050X-016K-6PB1-130D-W4-X01

konform ist zu den EU-Richtlinien /	<i>is conform with the EU directives</i>
2011/65/EU	Beschränkung der Verwendung bestimmter gefährlicher Stoffe in Elektro- und Elektronikgeräten (RoHS-Richtlinie) <i>Restriction of the use of certain hazardous substances in electrical and electronic equipment (RoHS directive)</i>
2014/34/EU	Geräte und Schutzsysteme zur bestimmungsgemäßen Verwendung in explosionsgefährdeten Bereichen (ATEX-Richtlinie) <i>Equipment and protective systems intended for use in potentially explosive atmospheres (ATEX directive)</i>

und die einschlägigen Bestimmungen dieser EU-Richtlinien erfüllt. / *and fulfills the relevant provisions of these EU directives.*
Das Erzeugnis erfüllt die den wesentlichen Anforderungen der oben genannten EU-Richtlinien entsprechenden Bestimmungen der harmonisierten Normen / *The product fulfills the essential requirements of the EU directives mentioned above by fulfilling the corresponding requirements of the harmonized standards*

EN 60079-0:2018	Explosionsgefährdete Bereiche - Teil 0: Betriebsmittel - Allgemeine Anforderungen <i>Explosive atmospheres - Part 0: Equipment - General requirements</i>
EN 60079-31:2014	Explosionsgefährdete Bereiche - Teil 31: Geräte-Staubexplosionsschutz durch Gehäuse "t" <i>Explosive atmospheres - Part 31: Equipment dust ignition protection by enclosure "t"</i>
EN 1127-1:2011	Explosionsfähige Atmosphären - Explosionsschutz - Teil 1: Grundlagen und Methodik <i>Explosive atmospheres - Explosion prevention and protection - Part 1: Basic concepts and methodology</i>
EN ISO 80079-36:2016	Explosionsfähige Atmosphären - Teil 36: Nicht-elektrische Geräte für den Einsatz in explosionsfähigen Atmosphären - Grundlagen und Anforderungen <i>Explosive atmospheres - Part 36: Non-electrical equipment for explosive atmospheres - Basic method and requirements</i>

Das Erzeugnis trägt das CE-Zeichen. / *The product bears the CE-marking.*

5055-D009161-04

Igersheim, den 22.03.2021
Ort und Datum der Ausstellung / Place
and date of declaration

Dr. Ingolf Gröning
Geschäftsführer / General Manager
WITTENSTEIN cyber motor GmbH

10 Appendix

10.1 Specifications for mounting onto a machine

10.1.1 Specifications for mounting to a machine (MRS)

Designation	Screw size	Property class	Tightening torque [Nm]
MRSR064	4x M4	10.9	3.88
MRSH064	4x M5	10.9	7.6
MRSx094	4x M8	10.9	32.0

Tbl-16: Specifications for mounting to a machine (MRS)

10.1.2 Specifications for mounting onto a machine (TPM⁺)

Designation	Bolt size	Property class	Tightening torque [Nm]
TPM⁺ 010	8x M5	12.9	9.0
TPM⁺ 050	12x M6	12.9	15.4

Tbl-17: Specifications for mounting onto a machine (TPM⁺)

Thread in output flange			
Type/Size	Hole circle Ø [mm]	Quantity x Thread x Depth [] x [mm] x [mm]	Tightening torque [Nm] Property class 12.9
TPM 010	50	8 x M6 x 10	15.4
TPM 050	80	11 x M8 x 15	37.3
Only for TPM 050: Index bore 8 H 7 x 10			

Tbl-18: Specifications for mounting onto the output side

10.1.3 Specifications for mounting onto a machine (ARS)

Designation	Bolt size	Property class	Tightening torque [Nm]
ARSx064	4x M6	Ax-80	8.42
ARSx094	4x M6	12.9	15.4

Tbl-19: Specifications for mounting onto a machine (ARS)

10.2 Tightening torques for common thread sizes in general mechanical engineering

The specified tightening torques for headless screws and nuts are calculated values and are based on the following conditions:

- Calculation according to VDI 2230 (edition 11/2015)
- Friction value for thread and contact surfaces $\mu=0.10$
- Utilization of the yield stress 90%
- Torque tools type II classes A and D in accordance with ISO 6789

The settings are values rounded to usual commercial scale gradations or settings.

- Use the **exact** values in this table to set your tools.

	Tightening torque [Nm] with thread												
Property class Screw / Nut	M2	M3	M4	M5	M6	M8	M10	M12	M14	M16	M18	M20	M22
8.8 / 8	0.323	1.15	2.64	5.2	9.0	21.5	42.5	73.5	118	180	258	362	495
10.9 / 10	0.474	1.68	3.88	7.6	13.2	32.0	62.5	108	173	264	368	520	700
12.9 / 12	0.555	1.97	4.55	9.0	15.4	37.5	73.5	126	202	310	430	605	820

Tbl-20: Tightening torques for headless screws and nuts

10.3 Tightening torques for common thread sizes with corrosion-resistant screw connections

The specified tightening torques for screws and nuts are calculated values and are based on the following conditions:

- Calculation based on VDI 2230 (February 2003 issue)
- Friction value for thread and contact surfaces $\mu=0.10$
- Exploitation of the yield stress 90%
- Only valid for:
 - Screws according to ISO 4762, ISO 4014, ISO 4017
 - Nuts according to ISO 4032, ISO 4033

The settings are values rounded to usual commercial scale gradations or setting possibilities.

- Set these values **precisely** on the scale.

	Tightening torque [Nm] with thread												
Property class screw / nut	M3	M4	M5	M6	M8	M10	M12	M14	M16	M18	M20	M22	M24
Ax-50	0.376	0.868	1.72	2.95	7.2	14.0	24.0	38.5	59.0	82.0	115	157	199
Ax-70	0.806	1.86	3.68	6.4	15.2	30.0	51.5	83.0	127	176	248	336	425
Ax-80	1.07	2.48	4.91	8.4	20.5	40.0	69.0	111	169	234	330	450	570

Tbl-21: Tightening torques for screws and nuts made from austenitic steel

Revision history

Revision	Date	Comment	Chapter
01	30.11.03	Original document	All
02	14.11.05	Extension MMSE-55	All
03	17.03.06	Extension ANSI	All
04	20.12.07	Approval number	2, 3
05	30.01.12	MMSE 100O-135E PTC triggering device	3, 5
06	16.07.12	Extension TPM 010, TPM 050	1, 3, 5, 6, 7
07	25.11.13	Cable strain-relief	2.7, 5.3
08	30.06.17	2014/34/EU	All
09	18.07.17	Lifetime	7.1.5, 7.3
10	15.01.18	Declaration of conformity TPM 050	9.7
11	04.12.19	Ex model	3.3
12	08.06.2020	Motor MMSE removed Lubricant Declaration of conformity	All 7 9
13	24.03.2021	Cable screw connection Thermal expansion Declaration of conformity Motor MMSE removed	5.4.2, 6.2 9 10.1.1



cyber motor

WITTENSTEIN cyber motor GmbH · Walter-Wittenstein-Straße 1 · 97999 Igersheim · Germany
Tel. +49 7931 493-15800 · info@wittenstein-cyber-motor.de

WITTENSTEIN Inc. · 1249 Humbracht Circle · Bartlett, IL 60103 · USA
Tel. +1 630 540 5300 · info@wittenstein-us.com

WITTENSTEIN S.P.A. · Via Giosuè Carducci 125 · 20099 Sesto San Giovanni MI · Italy
Tel. +39 02 241357-1 · info@wittenstein.it

WITTENSTEIN (Hangzhou) Co., Ltd. · No. 355 Tianmushan West Road · 311122 Hangzhou · Zhejiang · China
Tel. +86 571 8869 5852 / 5851 · info@wittenstein.cn

WITTENSTEIN Ltd. · 2-6-6 Shibadaimon · Minato-ku · Tokyo · 105-0012 Japan
Tel. +81 3 6680 2835 · sales@wittenstein.jp



WITTENSTEIN – eins sein mit der Zukunft

www.wittenstein-cyber-motor.de