

TK+ / TPK+ / TPK+ HIGH TORQUE – Space-saving right-angle precision with output flange

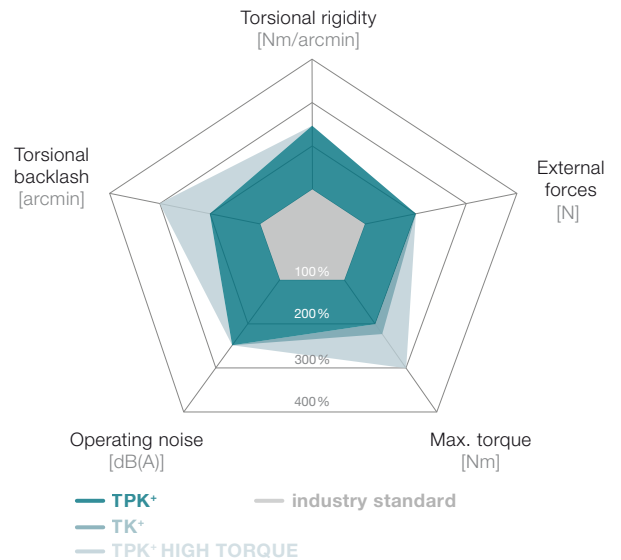

The versatile hypoid gearbox with TP+ compatible output flange and hollow shaft. TPK+ / TPK+ HIGH TORQUE gearboxes with planetary stage are especially suitable for high-precision applications requiring higher power and torsional rigidity.

The TK+ / TPK+ / TK+ HIGH TORQUE compared to the industry standard



Product highlights

Max. torsional backlash
 TK+ ≤ 4 arcmin (Standard)
 TPK+ ≤ 3.3 arcmin (Standard)
 ≤ 2 arcmin (Reduced)
 TPK+ HIGH TORQUE ≤ 1.3 arcmin (Standard)

Diverse range of ratios $i = 3 - 5,500$

High torque capacity (MA)

Multiple output configurations for greater flexibility
 Flanged hollow shaft, Flange, System output, Output on both sides

Other gearbox models
 Corrosion resistant design, ATEX (TK+)



TK+ in corrosion-resistant design

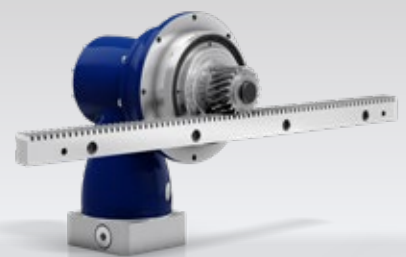

TPK+ with rack and pinion

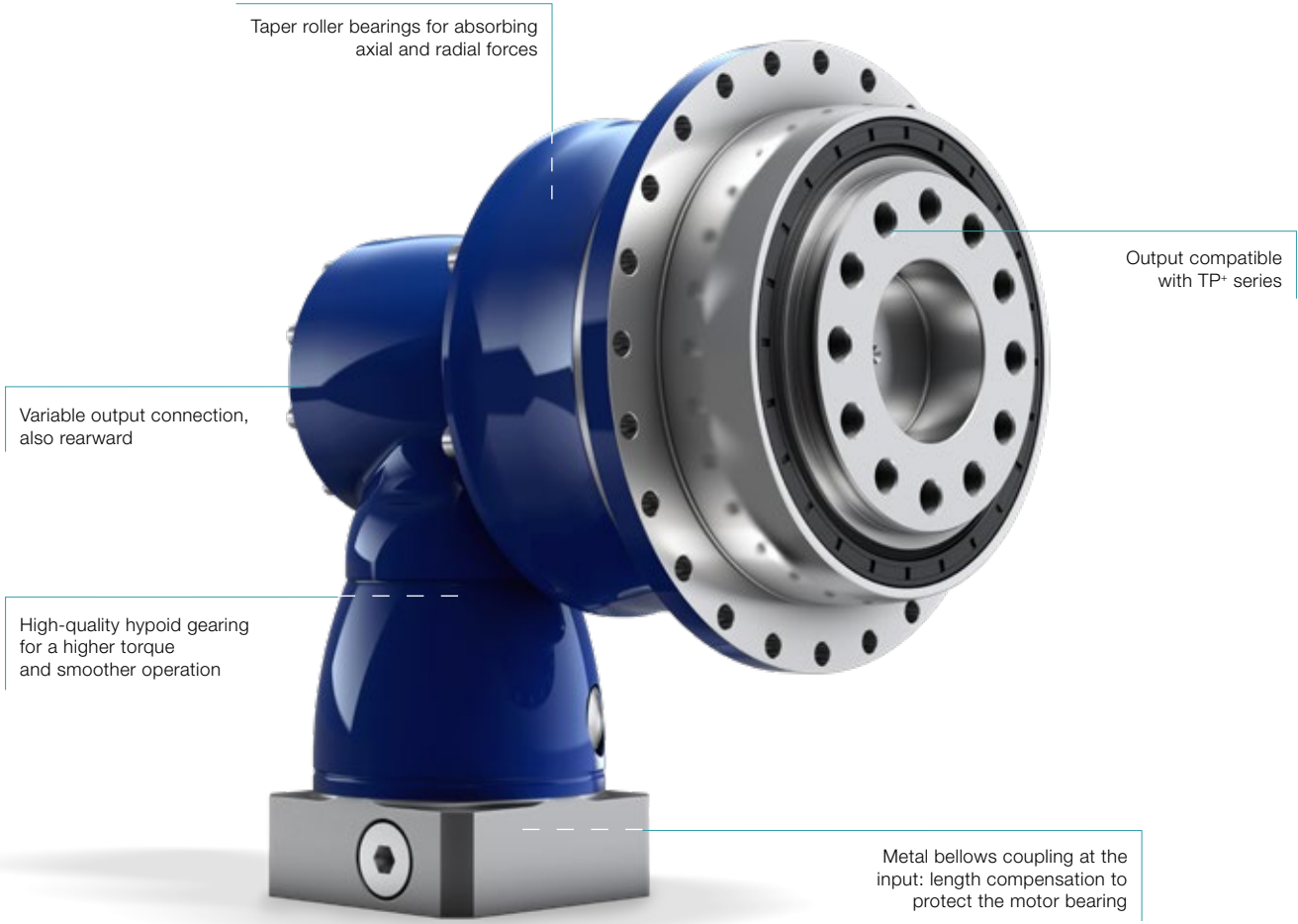

TPK+ HIGH TORQUE



TK+ with metal bellows coupling



TPK+ 2000 available on request

TK+ 004 MF 1-/2-stage

			1-stage					2-stage											
Ratio	<i>i</i>		3	4	5	7	10	12	16	20	25	28	35	40	50	70	100		
Max. torque ^{a) b)}	T_{2a}	Nm	36	36	36	25	20	36	36	36	36	36	36	36	36	25	20		
		in.lb	319	319	319	221	177	319	319	319	319	319	319	319	319	319	221	177	
Max. acceleration torque ^{b)} (max. 1000 cycles per hour)	T_{2B}	Nm	30	30	30	25	20	30	30	30	30	30	30	30	30	25	20		
		in.lb	266	266	266	221	177	266	266	266	266	266	266	266	266	221	177		
Nominal torque (at n_n)	T_{2N}	Nm	22	22	22	20	15	22	22	22	22	22	22	22	22	20	15		
		in.lb	195	195	195	177	133	195	195	195	195	195	195	195	195	177	133		
Emergency stop torque ^{a) b)} (permitted 1000 times during the service life of the gearbox)	T_{2Not}	Nm	40	50	50	45	40	50	50	50	50	50	50	50	50	45	40		
		in.lb	354	443	443	398	354	443	443	443	443	443	443	443	443	443	398	354	
Permitted average input speed (at T_{2a} and 20 °C ambient temperature ^{d)})	n_{1N}	n_{1T}	2200	2400	2700	2700	2700	4400	4400	4400	4400	4400	4400	4400	4400	4800	5500		
Max. input speed	n_{1Max}	rpm	7500	7500	7500	7500	7500	6000	6000	6000	6000	6000	6000	6000	6000	6000	6000		
Mean no load running torque ^{b)} (at $n_i = 3000$ rpm and 20 °C gearbox temperature)	T_{012}	Nm	1.9	1.8	1.4	1.5	1.4	0.2	0.2	0.2	0.2	0.2	0.2	0.2	0.2	0.2	0.2		
		in.lb	17	16	12	13	12	1.8	1.8	1.8	1.8	1.8	1.8	1.8	1.8	1.8	1.8		
Max. backlash	j_t	arcmin	Standard ≤ 5																
Torsional rigidity ^{b)}	C_{t21}	Nm/arcmin	2.6	2.8	3	2.6	2.3	2.8	2.8	2.8	2.8	2.8	2.8	2.8	2.8	3	2.6	2.3	
		in.lb/arcmin	23	25	27	23	20	25	25	25	25	25	25	25	25	27	23	20	
Max. axial force ^{c)}	F_{2AMax}	N	2400																
		lb _f	540																
Max. tilting moment	M_{2KMax}	Nm	251																
		in.lb	2222																
Efficiency at full load	η	%	96					94											
Service life ^{f)}	L_h	h	> 20000																
Weight (incl. standard adapter plate)	m	kg	2.9					3.2											
		lb _m	6					7											
Operating noise (at reference ratio and reference speed – ratio-specific values available in cymex [®])	L_{PA}	dB(A)	≤ 64																
Max. permitted housing temperature		°C	+90																
		F	194																
Ambient temperature		°C	0 to +40																
		F	32 to 104																
Lubrication			Lubricated for life																
Direction of rotation			In- and output opposite direction																
Protection class			IP 65																
Metal bellows coupling (recommended product type – validate sizing with cymex [®])			BCT - 00015AAX - 031.500																
Bore diameter of coupling on the application side		mm	X = 012.000 - 028.000																
Mass moment of inertia (relates to the drive) Clamping hub diameter [mm]	B	11	J_1	kgcm ²	-	-	-	-	-	0.09	0.09	0.07	0.07	0.06	0.06	0.06	0.06	0.06	
				10 ⁻³ in.lb.s ²	-	-	-	-	-	0.08	0.08	0.06	0.06	0.05	0.05	0.05	0.05	0.05	0.05
	C	14	J_1	kgcm ²	0.57	0.46	0.41	0.37	0.35	0.21	0.2	0.19	0.19	0.18	0.18	0.17	0.17	0.17	0.17
				10 ⁻³ in.lb.s ²	0.5	0.41	0.36	0.33	0.31	0.19	0.18	0.17	0.17	0.16	0.16	0.15	0.15	0.15	0.15
E	19	J_1	kgcm ²	0.92	0.82	0.76	0.72	0.7	-	-	-	-	-	-	-	-	-	-	
			10 ⁻³ in.lb.s ²	0.81	0.73	0.67	0.64	0.62	-	-	-	-	-	-	-	-	-	-	-

Please use our sizing software cymex[®] for a detailed sizing – www.wittenstein-cymex.com
Please contact us for optimum sizing at S1 conditions (Continuous operation).

- ^{a)} At max. 10 % M_{2KMax}
- ^{b)} Valid for standard clamping hub diameter
- ^{c)} Refers to center of the output shaft or flange
- ^{d)} Please reduce input speed at higher ambient temperatures
- ^{f)} Please contact us to discuss application-specific service lifetimes

View A

1-stage

up to 14/19⁴⁾
(C⁶⁾/E) clamping
hub diameter

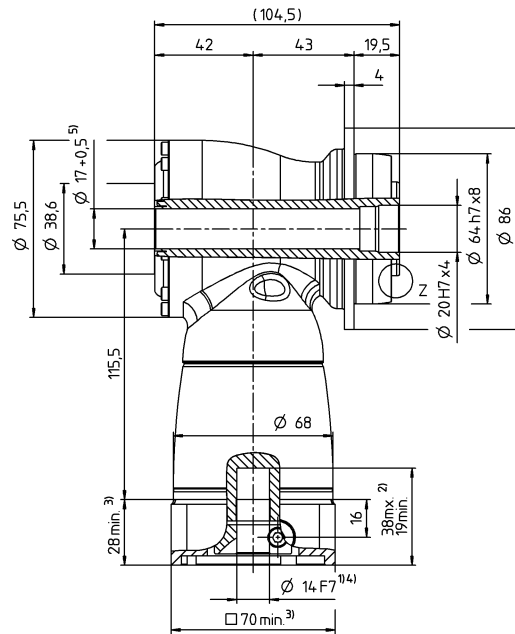
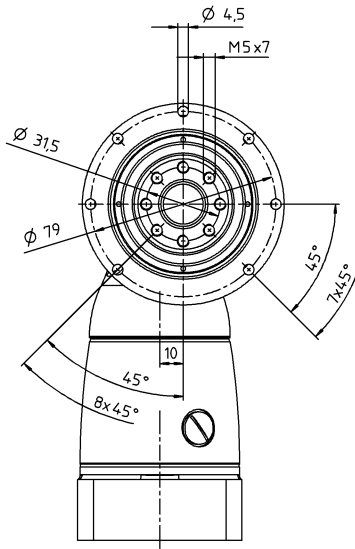

2-stage

up to 11/14⁴⁾
(B⁶⁾/C) clamping
hub diameter

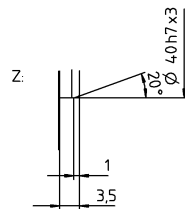
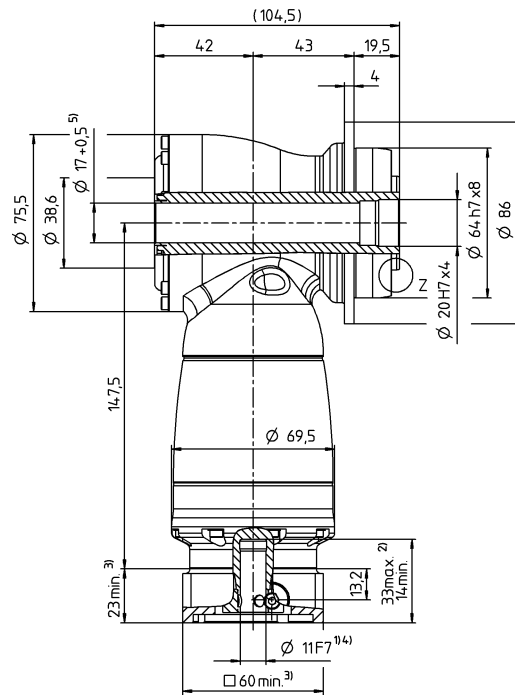
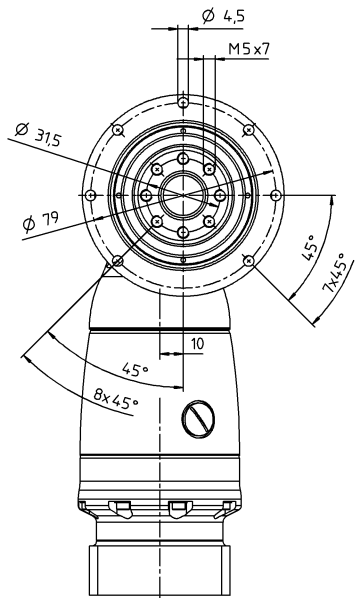

Motor shaft diameter [mm]

Hypoid gearboxes

TK

See technical data sheet for available clamping hub diameters (mass moment of inertia). Dimensions available on request.

Non-tolerated dimensions are nominal dimensions

¹⁾ Check motor shaft fit

²⁾ Min./Max. permissible motor shaft length. Longer motor shafts are possible, please contact alpha.

³⁾ The dimensions depend on the motor

⁴⁾ Smaller motor shaft diameter is compensated by a bushing with a minimum wall thickness of 1 mm

⁵⁾ Led through element max. Ø 16.8 mm

⁶⁾ Standard clamping hub diameter

TK+ 010 MF 1-/2-stage

			1-stage					2-stage											
Ratio	<i>i</i>		3	4	5	7	10	12	16	20	25	28	35	40	50	70	100		
Max. torque ^{a) b)}	T_{2a}	Nm	84	84	84	60	50	84	84	84	84	84	84	84	84	60	50		
		in.lb	743	743	743	531	443	743	743	743	743	743	743	743	743	743	531	443	
Max. acceleration torque ^{b)} (max. 1000 cycles per hour)	T_{2B}	Nm	70	70	70	60	50	70	70	70	70	70	70	70	70	60	50		
		in.lb	620	620	620	531	443	620	620	620	620	620	620	620	620	620	531	443	
Nominal torque (at n_n)	T_{2N}	Nm	50	50	50	45	40	50	50	50	50	50	50	50	50	45	40		
		in.lb	443	443	443	398	354	443	443	443	443	443	443	443	443	443	398	354	
Emergency stop torque ^{a) b)} (permitted 1000 times during the service life of the gearbox)	T_{2Not}	Nm	95	115	115	110	100	115	115	115	115	115	115	115	115	110	100		
		in.lb	841	1018	1018	974	885	1018	1018	1018	1018	1018	1018	1018	1018	1018	974	885	
Permitted average input speed (at T_{2a} and 20 °C ambient temperature ^{d)})	n_{1N}	n_{1T}	2100	2200	2500	2500	2500	3500	3500	3500	3500	3500	3500	3500	3800	4500	4500		
Max. input speed	n_{1Max}	rpm	7500	7500	7500	7500	7500	6000	6000	6000	6000	6000	6000	6000	6000	6000	6000		
Mean no load running torque ^{b)} (at $n_i = 3000$ rpm and 20 °C gearbox temperature)	T_{012}	Nm	3.3	2.8	2.1	2.4	2.2	0.4	0.4	0.3	0.3	0.3	0.3	0.2	0.2	0.2	0.2		
		in.lb	29	25	19	21	19	3.5	3.5	2.7	2.7	2.7	2.7	1.8	1.8	1.8	1.8		
Max. backlash	j_t	arcmin	Standard ≤ 4																
Torsional rigidity ^{b)}	C_{t21}	Nm/arcmin	6	7	8	8	8	7	7	7	7	7	7	7	8	8	8		
		in.lb/arcmin	53	62	71	71	71	62	62	62	62	62	62	62	71	71	71		
Max. axial force ^{c)}	F_{2AMax}	N	3400																
		lb _f	765																
Max. tilting moment	M_{2KMax}	Nm	437																
		in.lb	3868																
Efficiency at full load	η	%	96					94											
Service life ^{f)}	L_h	h	> 20000																
Weight (incl. standard adapter plate)	m	kg	5.3					6.1											
		lb _m	12					13											
Operating noise (at reference ratio and reference speed – ratio-specific values available in cymex [®])	L_{PA}	dB(A)	≤ 66																
Max. permitted housing temperature		°C	+90																
		F	194																
Ambient temperature		°C	0 to +40																
		F	32 to 104																
Lubrication			Lubricated for life																
Direction of rotation			In- and output opposite direction																
Protection class			IP 65																
Metal bellows coupling (recommended product type – validate sizing with cymex [®])			BCT - 00060AAX - 050.000																
Bore diameter of coupling on the application side		mm	X = 014.000 - 035.000																
Mass moment of inertia (relates to the drive) Clamping hub diameter [mm]	C	14	J_1	kgcm ²	-	-	-	-	-	0.31	0.28	0.24	0.23	0.21	0.2	0.19	0.18	0.18	
				10 ⁻³ in.lb.s ²	-	-	-	-	-	0.27	0.25	0.21	0.2	0.19	0.18	0.17	0.16	0.16	0.16
	E	19	J_1	kgcm ²	1.81	1.39	1.18	1.02	0.93	0.75	0.72	0.68	0.68	0.63	0.63	0.63	0.63	0.63	0.63
				10 ⁻³ in.lb.s ²	1.6	1.23	1.04	0.9	0.82	0.66	0.64	0.6	0.6	0.56	0.56	0.56	0.56	0.56	0.56
H	28	J_1	kgcm ²	3.22	2.8	2.6	2.43	2.34	-	-	-	-	-	-	-	-	-	-	
			10 ⁻³ in.lb.s ²	2.85	2.48	2.3	2.15	2.07	-	-	-	-	-	-	-	-	-	-	-

Please use our sizing software cymex[®] for a detailed sizing – www.wittenstein-cymex.com
Please contact us for optimum sizing at S1 conditions (Continuous operation).

- ^{a)} At max. 10 % M_{2KMax}
- ^{b)} Valid for standard clamping hub diameter
- ^{c)} Refers to center of the output shaft or flange
- ^{d)} Please reduce input speed at higher ambient temperatures
- ^{f)} Please contact us to discuss application-specific service lifetimes

View A

1-stage

up to 19/28⁴⁾
(E⁶⁾/H) clamping
hub diameter

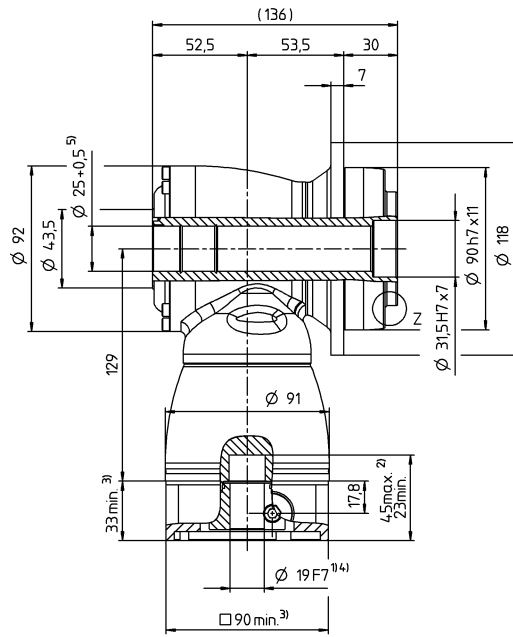
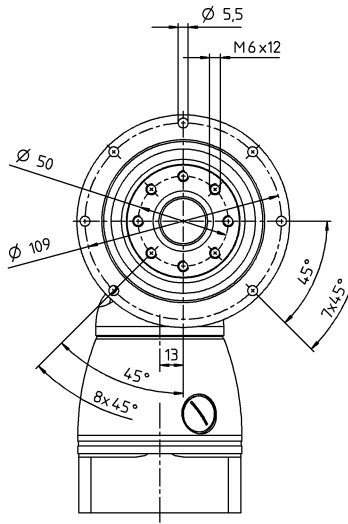

2-stage

up to 14/19⁴⁾
(C⁶⁾/E) clamping
hub diameter

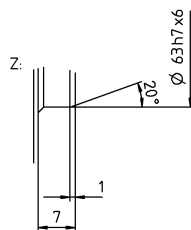
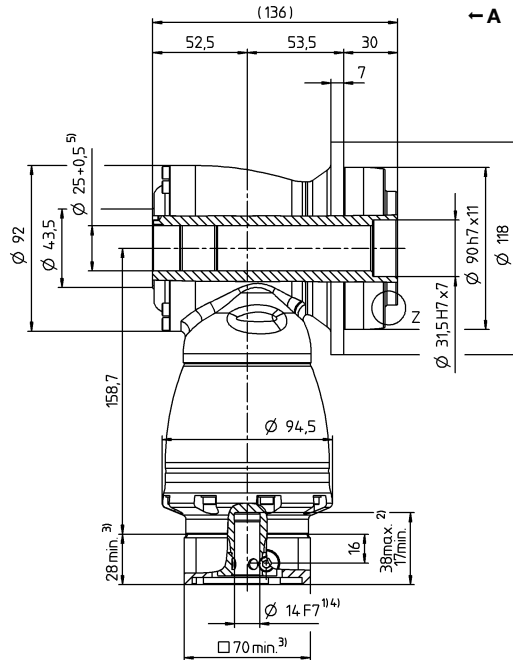
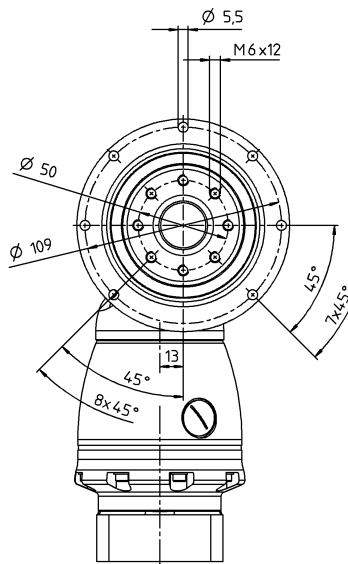

Motor shaft diameter [mm]

Hypoid gearboxes

TK

See technical data sheet for available clamping hub diameters (mass moment of inertia). Dimensions available on request.

Non-tolerated dimensions are nominal dimensions

¹⁾ Check motor shaft fit

²⁾ Min./Max. permissible motor shaft length. Longer motor shafts are possible, please contact alpha.

³⁾ The dimensions depend on the motor

⁴⁾ Smaller motor shaft diameter is compensated by a bushing with a minimum wall thickness of 1 mm

⁵⁾ Led through element max. Ø 24.8 mm

⁶⁾ Standard clamping hub diameter

TK+ 025 MF 1-/2-stage

			1-stage					2-stage											
Ratio	<i>i</i>		3	4	5	7	10	12	16	20	25	28	35	40	50	70	100		
Max. torque ^{a) b)}	T_{2a}	Nm	204	204	204	145	125	204	204	204	204	204	204	204	204	145	125		
		in.lb	1806	1806	1806	1283	1106	1806	1806	1806	1806	1806	1806	1806	1806	1806	1283	1106	
Max. acceleration torque ^{b)} (max. 1000 cycles per hour)	T_{2B}	Nm	170	170	170	145	125	170	170	170	170	170	170	170	170	145	125		
		in.lb	1505	1505	1505	1283	1106	1505	1505	1505	1505	1505	1505	1505	1505	1505	1283	1106	
Nominal torque (at n_n)	T_{2N}	Nm	100	100	100	90	80	100	100	100	100	100	100	100	100	90	80		
		in.lb	885	885	885	797	708	885	885	885	885	885	885	885	885	885	797	708	
Emergency stop torque ^{a) b)} (permitted 1000 times during the service life of the gearbox)	T_{2Not}	Nm	220	260	260	255	250	260	260	260	260	260	260	260	260	260	255	250	
		in.lb	1947	2301	2301	2257	2213	2301	2301	2301	2301	2301	2301	2301	2301	2301	2257	2213	
Permitted average input speed (at T_{2a} and 20 °C ambient temperature ^{d)})	n_{1N}	n_{1T}	2000	2100	2400	2200	2200	3100	3100	3100	3100	3100	3100	3100	3100	3500	4200	4200	
Max. input speed	n_{1Max}	rpm	5500	5500	5500	5500	5500	4500	4500	4500	4500	4500	4500	4500	4500	4500	4500		
Mean no load running torque ^{b)} (at $n_i = 3000$ rpm and 20 °C gearbox temperature)	T_{012}	Nm	4.9	3.9	4	4.5	3.6	0.7	0.7	0.6	0.5	0.5	0.4	0.2	0.2	0.2	0.2		
		in.lb	43	35	35	40	32	6.2	6.2	5.3	4.4	4.4	3.5	1.8	1.8	1.8	1.8		
Max. backlash	j_t	arcmin	Standard ≤ 4																
Torsional rigidity ^{b)}	C_{t21}	Nm/arcmin	12	13	16	16	16	13	13	13	13	13	13	13	16	16	16		
		in.lb/arcmin	106	115	142	142	142	115	115	115	115	115	115	115	142	142	142		
Max. axial force ^{c)}	F_{2AMax}	N	5700																
		lb _f	1283																
Max. tilting moment	M_{2KMax}	Nm	833																
		in.lb	7373																
Efficiency at full load	η	%	96					94											
Service life ^{f)}	L_h	h	> 20000																
Weight (incl. standard adapter plate)	m	kg	8.9					10.6											
		lb _m	20					23											
Operating noise (at reference ratio and reference speed – ratio-specific values available in cymex [®])	L_{PA}	dB(A)	≤ 66																
Max. permitted housing temperature		°C	+90																
		F	194																
Ambient temperature		°C	0 to +40																
		F	32 to 104																
Lubrication			Lubricated for life																
Direction of rotation			In- and output opposite direction																
Protection class			IP 65																
Metal bellows coupling (recommended product type – validate sizing with cymex [®])			BCT - 00150AAX - 063.000																
Bore diameter of coupling on the application side		mm	X = 019.000 - 042.000																
Mass moment of inertia (relates to the drive) Clamping hub diameter [mm]	E	19	J_1	kgcm ²	-	-	-	-	-	1.08	1.01	0.88	0.85	0.76	0.75	0.7	0.69	0.68	0.68
				10 ⁻³ in.lb.s ²	-	-	-	-	-	0.96	0.89	0.78	0.75	0.67	0.66	0.62	0.61	0.6	0.6
	G	24	J_1	kgcm ²	-	-	-	-	-	2.65	2.57	2.44	2.42	2.32	2.31	2.26	2.25	2.25	2.25
				10 ⁻³ in.lb.s ²	-	-	-	-	-	2.35	2.27	2.16	2.14	2.05	2.04	2	1.99	1.99	1.99
	H	28	J_1	kgcm ²	5.5	4.3	3.6	3.1	2.9	-	-	-	-	-	-	-	-	-	-
				10 ⁻³ in.lb.s ²	4.87	3.81	3.19	2.74	2.57	-	-	-	-	-	-	-	-	-	-
	K	38	J_1	kgcm ²	12.7	11.5	10.9	10.4	10.1	-	-	-	-	-	-	-	-	-	-
				10 ⁻³ in.lb.s ²	11.24	10.18	9.65	9.2	8.94	-	-	-	-	-	-	-	-	-	-

Please use our sizing software cymex[®] for a detailed sizing – www.wittenstein-cymex.com
Please contact us for optimum sizing at S1 conditions (Continuous operation).

- ^{a)} At max. 10 % M_{2KMax}
- ^{b)} Valid for standard clamping hub diameter
- ^{c)} Refers to center of the output shaft or flange
- ^{d)} Please reduce input speed at higher ambient temperatures
- ^{f)} Please contact us to discuss application-specific service lifetimes

View A

1-stage

up to 28/38⁴⁾
(H⁶⁾/K) clamping
hub diameter

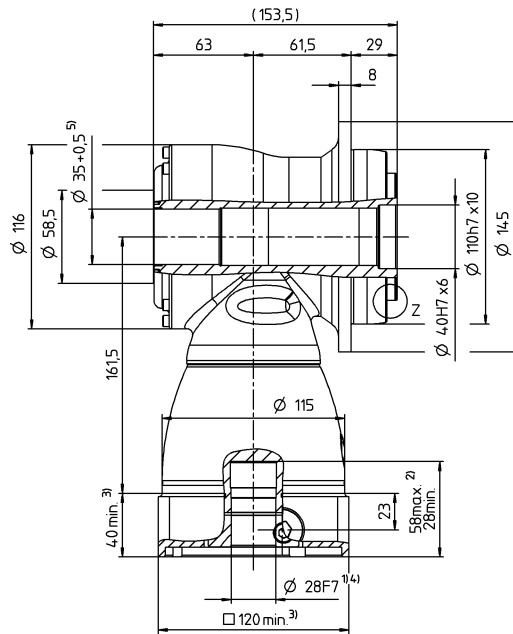
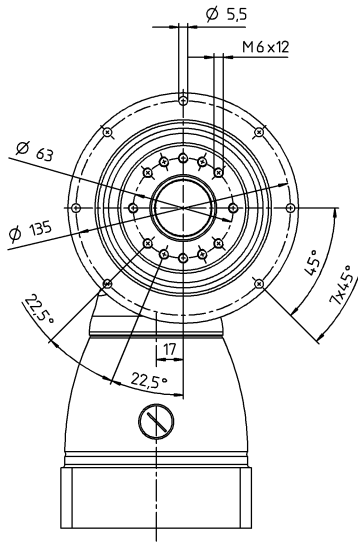

2-stage

up to 19/24⁴⁾
(E⁶⁾/G) clamping
hub diameter

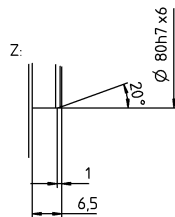
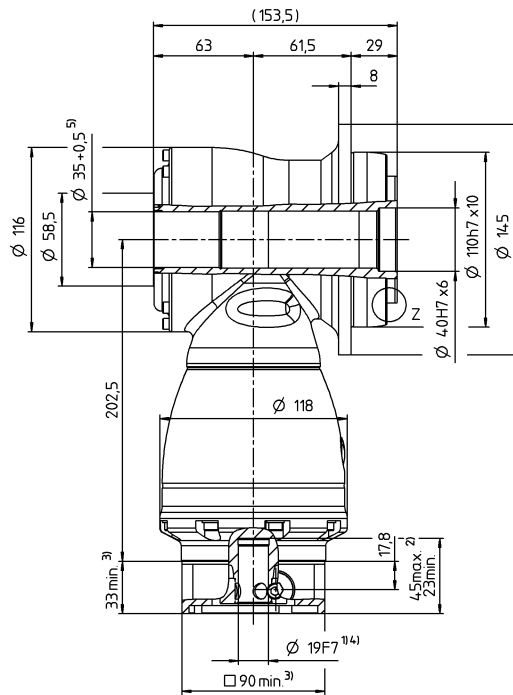
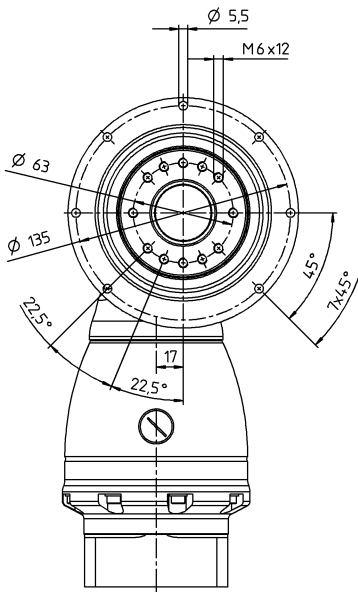

Motor shaft diameter [mm]

Hypoid gearboxes

TK

See technical data sheet for available clamping hub diameters (mass moment of inertia). Dimensions available on request.

- Non-tolerated dimensions are nominal dimensions
- ¹⁾ Check motor shaft fit
- ²⁾ Min./Max. permissible motor shaft length. Longer motor shafts are possible, please contact alpha.
- ³⁾ The dimensions depend on the motor
- ⁴⁾ Smaller motor shaft diameter is compensated by a bushing with a minimum wall thickness of 1 mm
- ⁵⁾ Led through element max. Ø 34.8 mm
- ⁶⁾ Standard clamping hub diameter

TK+ 050 MF 1-/2-stage

			1-stage					2-stage											
Ratio	<i>i</i>		3	4	5	7	10	12	16	20	25	28	35	40	50	70	100		
Max. torque ^{a) b)}	T_{2a}	Nm	360	360	360	250	210	360	360	360	360	360	360	360	360	250	210		
		in.lb	3186	3186	3186	2213	1859	3186	3186	3186	3186	3186	3186	3186	3186	3186	2213	1859	
Max. acceleration torque ^{b)} (max. 1000 cycles per hour)	T_{2B}	Nm	300	300	300	250	210	300	300	300	300	300	300	300	300	250	210		
		in.lb	2655	2655	2655	2213	1859	2655	2655	2655	2655	2655	2655	2655	2655	2213	1859		
Nominal torque (at n_n)	T_{2N}	Nm	190	190	190	175	160	190	190	190	190	190	190	190	190	175	160		
		in.lb	1682	1682	1682	1549	1416	1682	1682	1682	1682	1682	1682	1682	1682	1549	1416		
Emergency stop torque ^{a) b)} (permitted 1000 times during the service life of the gearbox)	T_{2Not}	Nm	400	500	500	450	400	500	500	500	500	500	500	500	500	450	400		
		in.lb	3540	4425	4425	3983	3540	4425	4425	4425	4425	4425	4425	4425	4425	3983	3540		
Permitted average input speed (at T_{2a} and 20 °C ambient temperature ^{d)})	n_{1N}	n_{1T}	1700	1800	2000	1800	1800	2900	2900	2900	2900	2900	2900	2900	3200	3200	3900		
Max. input speed	n_{1Max}	rpm	5000	5000	5000	5000	5000	4500	4500	4500	4500	4500	4500	4500	4500	4500	4500		
Mean no load running torque ^{b)} (at $n_i = 3000$ rpm and 20 °C gearbox temperature)	T_{012}	Nm	9.6	7.1	8.4	9	6.6	1.7	1.1	0.8	0.6	0.6	0.5	0.5	0.4	0.4	0.4		
		in.lb	85	63	74	80	58	15	9.7	7.1	5.3	5.3	4.4	4.4	3.5	3.5	3.5		
Max. backlash	j_t	arcmin	Standard ≤ 4																
Torsional rigidity ^{b)}	C_{t21}	Nm/arcmin	36	40	46	44	42	40	40	40	40	40	40	40	46	44	42		
		in.lb/arcmin	319	354	407	389	372	354	354	354	354	354	354	354	407	389	372		
Max. axial force ^{c)}	F_{2AMax}	N	9900																
		lb _f	2228																
Max. tilting moment	M_{2KMax}	Nm	1692																
		in.lb	14976																
Efficiency at full load	η	%	96					94											
Service life ^{f)}	L_h	h	> 20000																
Weight (incl. standard adapter plate)	m	kg	22					26											
		lb _m	49					57											
Operating noise (at reference ratio and reference speed – ratio-specific values available in cymex [®])	L_{PA}	dB(A)	≤ 68																
Max. permitted housing temperature		°C	+90																
		F	194																
Ambient temperature		°C	0 to +40																
		F	32 to 104																
Lubrication			Lubricated for life																
Direction of rotation			In- and output opposite direction																
Protection class			IP 65																
Metal bellows coupling (recommended product type – validate sizing with cymex [®])			BCT - 00300AAX - 080.000																
Bore diameter of coupling on the application side		mm	X = 024.000 - 060.000																
Mass moment of inertia (relates to the drive)	G	24	J_1	kgcm ²	-	-	-	-	-	4.43	3.97	3.36	3.22	2.82	2.75	2.5	2.47	2.44	2.42
				10 ⁻³ in.lb.s ²	-	-	-	-	-	3.92	3.51	2.97	2.85	2.5	2.43	2.21	2.19	2.16	2.14
Clamping hub diameter [mm]	K	38	J_1	kgcm ²	28.4	21	17.6	14.7	13.1	11.3	10.9	10.3	10.1	9.74	9.66	9.41	9.38	9.35	9.33
				10 ⁻³ in.lb.s ²	25.13	18.59	15.58	13.01	11.59	10	9.65	9.12	8.94	8.62	8.55	8.33	8.3	8.27	8.26

Please use our sizing software cymex[®] for a detailed sizing – www.wittenstein-cymex.com
Please contact us for optimum sizing at S1 conditions (Continuous operation).

- ^{a)} At max. 10 % M_{2KMax}
- ^{b)} Valid for standard clamping hub diameter
- ^{c)} Refers to center of the output shaft or flange
- ^{d)} Please reduce input speed at higher ambient temperatures
- ^{f)} Please contact us to discuss application-specific service lifetimes

View A

1-stage

up to 38⁴⁾ (K)⁶⁾
clamping hub diameter

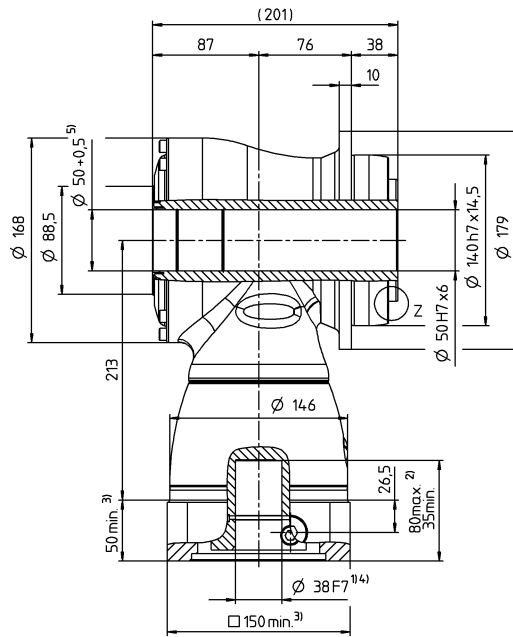
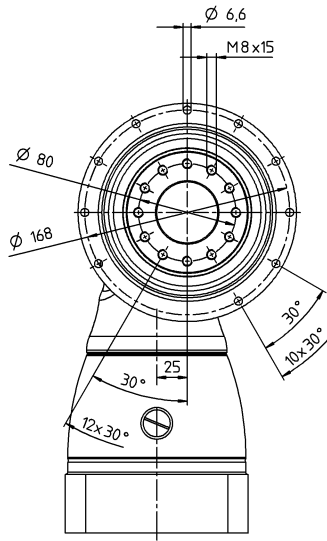

2-stage

up to 24/38⁴⁾
(G⁶⁾/K) clamping
hub diameter

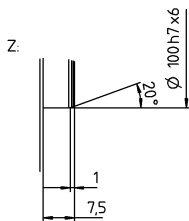
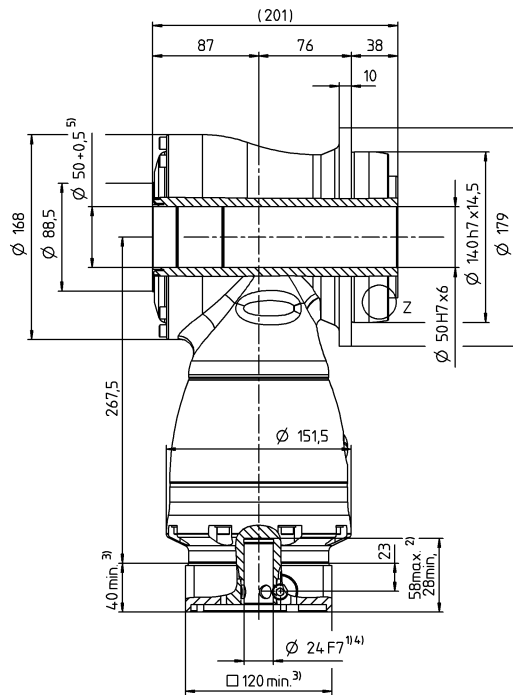
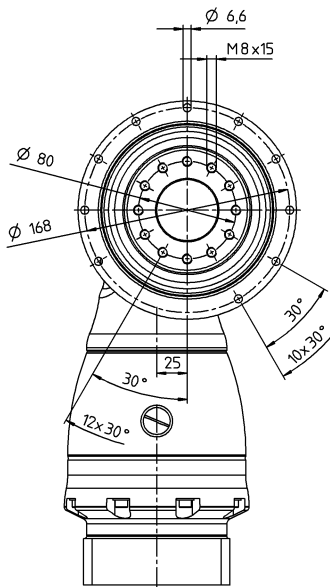

Motor shaft diameter [mm]

Hypoid gearboxes

TK

See technical data sheet for available clamping hub diameters (mass moment of inertia). Dimensions available on request.

Non-tolerated dimensions are nominal dimensions

¹⁾ Check motor shaft fit

²⁾ Min./Max. permissible motor shaft length. Longer motor shafts are possible, please contact alpha.

³⁾ The dimensions depend on the motor

⁴⁾ Smaller motor shaft diameter is compensated by a bushing with a minimum wall thickness of 1 mm

⁵⁾ Led through element max. Ø 49.8 mm

⁶⁾ Standard clamping hub diameter

TK+ 110 MF 1-/2-stage

			1-stage					2-stage											
Ratio	<i>i</i>		3	4	5	7	10	12	16	20	25	28	35	40	50	70	100		
Max. torque ^{a) b)}	T_{2a}	Nm	768	768	768	550	470	768	768	768	768	768	768	768	768	550	470		
		in.lb	6797	6797	6797	4868	4160	6797	6797	6797	6797	6797	6797	6797	6797	6797	4868	4160	
Max. acceleration torque ^{b)} (max. 1000 cycles per hour)	T_{2B}	Nm	640	640	640	550	470	640	640	640	640	640	640	640	640	550	470		
		in.lb	5665	5665	5665	4868	4160	5665	5665	5665	5665	5665	5665	5665	5665	5665	4868	4160	
Nominal torque (at n_n)	T_{2N}	Nm	400	400	400	380	360	400	400	400	400	400	400	400	400	380	360		
		in.lb	3540	3540	3540	3363	3186	3540	3540	3540	3540	3540	3540	3540	3540	3540	3363	3186	
Emergency stop torque ^{a) b)} (permitted 1000 times during the service life of the gearbox)	T_{2Not}	Nm	900	1050	1050	970	900	1050	1050	1050	1050	1050	1050	1050	1050	1050	970	900	
		in.lb	7966	9293	9293	8585	7966	9293	9293	9293	9293	9293	9293	9293	9293	9293	8585	7966	
Permitted average input speed (at T_{2a} and 20 °C ambient temperature ^{d)})	n_{1N}	n_{1T}	1400	1600	1800	1600	1600	2700	2700	2700	2700	2700	2700	2700	2700	2900	3200	3400	
Max. input speed	n_{1Max}	rpm	4500	4500	4500	4500	4500	4000	4000	4000	4000	4000	4000	4000	4000	4000	4000		
Mean no load running torque ^{b)} (at $n_i = 3000$ rpm and 20 °C gearbox temperature)	T_{012}	Nm	20	17	18	19	16	3.6	2.8	2.2	1.9	1.6	1.4	1.1	1.1	1.1	1.1		
		in.lb	177	150	159	168	142	32	25	19	17	14	12	9.7	9.7	9.7	9.7		
Max. backlash	j_t	arcmin	Standard ≤ 4																
Torsional rigidity ^{b)}	C_{t21}	Nm/arcmin	76	87	99	97	96	87	87	87	87	87	87	87	99	97	96		
		in.lb/arcmin	673	770	876	859	850	770	770	770	770	770	770	770	876	859	850		
Max. axial force ^{c)}	F_{2AMax}	N	14200																
		lb _f	3195																
Max. tilting moment	M_{2KMax}	Nm	3213																
		in.lb	28438																
Efficiency at full load	η	%	96					94											
Service life ^{f)}	L_h	h	> 20000																
Weight (incl. standard adapter plate)	m	kg	48					54											
		lb _m	106					119											
Operating noise (at reference ratio and reference speed – ratio-specific values available in cymex [®])	L_{PA}	dB(A)	≤ 68																
Max. permitted housing temperature		°C	+90																
		F	194																
Ambient temperature		°C	0 to +40																
		F	32 to 104																
Lubrication			Lubricated for life																
Direction of rotation			In- and output opposite direction																
Protection class			IP 65																
Metal bellows coupling (recommended product type – validate sizing with cymex [®])			BCT - 01500AAX - 125.000																
Bore diameter of coupling on the application side		mm	X = 050.000 - 080.000																
Mass moment of inertia (relates to the drive)	K	38	J_1	kgcm ²	-	-	-	-	-	16.8	14.8	12.9	12.3	11.2	10.9	10.3	10.1	10	9.93
				10 ⁻³ in.lb.s ²	-	-	-	-	-	14.87	13.1	11.42	10.89	9.91	9.65	9.12	8.94	8.85	8.79
Clamping hub diameter [mm]	M	48	J_1	kgcm ²	96.5	64.6	50.5	38.2	31.8	31.5	29.5	27.6	27	25.9	25.6	25	24.8	24.7	24.6
				10 ⁻³ in.lb.s ²	85.4	57.17	44.69	33.81	28.14	27.88	26.11	24.43	23.9	22.92	22.66	22.13	21.95	21.86	21.77

Please use our sizing software cymex[®] for a detailed sizing – www.wittenstein-cymex.com
Please contact us for optimum sizing at S1 conditions (Continuous operation).

- ^{a)} At max. 10 % M_{2KMax}
- ^{b)} Valid for standard clamping hub diameter
- ^{c)} Refers to center of the output shaft or flange
- ^{d)} Please reduce input speed at higher ambient temperatures
- ^{f)} Please contact us to discuss application-specific service lifetimes

View A

1-stage

up to 48⁴⁾ (M)⁶⁾
clamping hub diameter

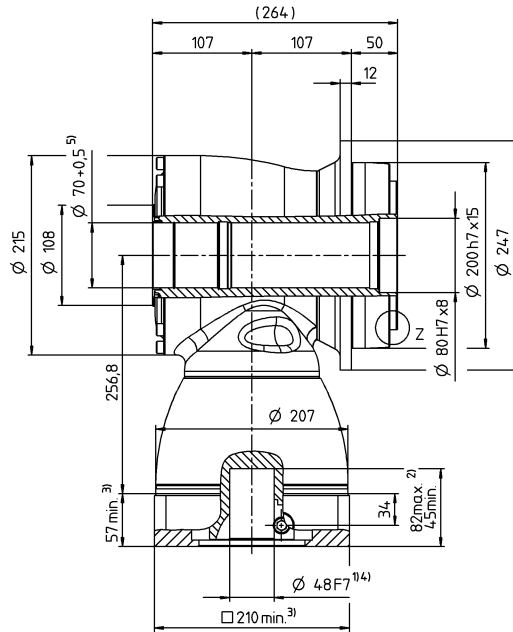
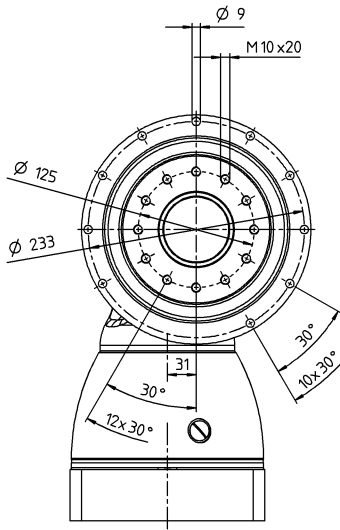

2-stage

up to 38/48⁴⁾
(K⁶⁾/M) clamping hub diameter

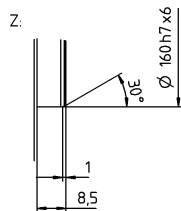
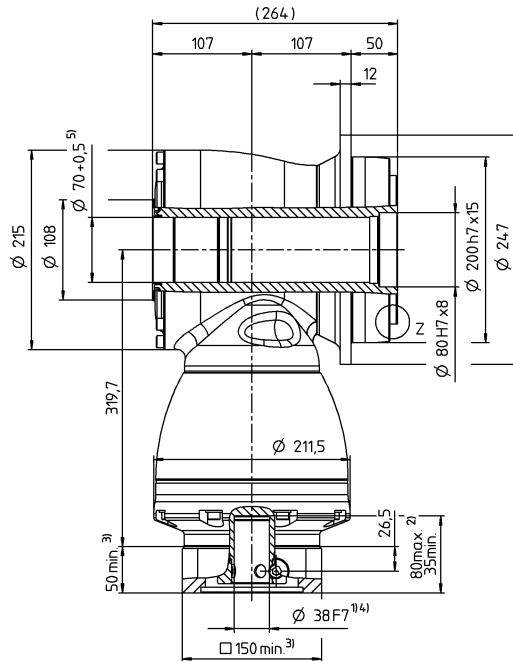
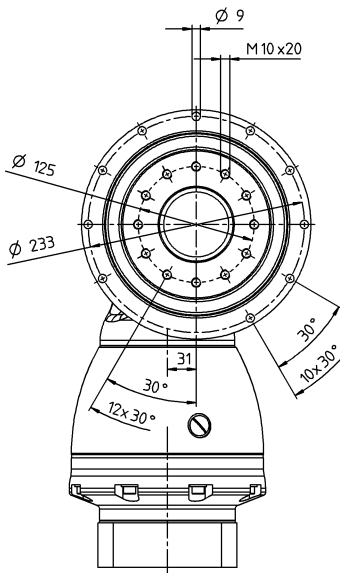

Motor shaft diameter [mm]

Hypoid gearboxes

TK

See technical data sheet for available clamping hub diameters (mass moment of inertia). Dimensions available on request.

Non-tolerated dimensions are nominal dimensions

¹⁾ Check motor shaft fit

²⁾ Min./Max. permissible motor shaft length. Longer motor shafts are possible, please contact alpha.

³⁾ The dimensions depend on the motor

⁴⁾ Smaller motor shaft diameter is compensated by a bushing with a minimum wall thickness of 1 mm

⁵⁾ Led through element max. Ø 69.8 mm

⁶⁾ Standard clamping hub diameter

TPK+ 010 MF 2-stage

			2-stage												
Ratio	<i>i</i>		12	16	20	25	28	35	40	49	50	70	100		
Max. torque ^{a) b)}	T_{2a}	Nm	144	144	180	180	210	210	80	175	100	140	168		
		in.lb	1275	1275	1593	1593	1859	1859	708	1549	885	1239	1487		
Max. acceleration torque ^{b)} (max. 1000 cycles per hour)	T_{2B}	Nm	120	120	150	150	172	172	80	172	100	140	126		
		in.lb	1062	1062	1328	1328	1522	1522	708	1522	885	1239	1115		
Nominal torque (at n_n)	T_{2N}	Nm	75	75	75	75	75	75	60	75	75	75	60		
		in.lb	664	664	664	664	664	664	531	664	664	664	531		
Emergency stop torque ^{a) b)} (permitted 1000 times during the service life of the gearbox)	T_{2Not}	Nm	160	200	250	250	251	251	160	251	200	251	251		
		in.lb	1416	1770	2213	2213	2222	2222	1416	2222	1770	2222	2222		
Permitted average input speed (at T_{2a} and 20 °C ambient temperature) ^{d)}	n_{1N}	n_{1T}	2000	2400	2400	2700	2400	2500	2500	2500	2500	2500	2500		
Max. input speed	n_{1Max}	rpm	7500	7500	7500	7500	7500	7500	7500	7500	7500	7500	7500		
Mean no load running torque ^{b)} (at $n_1 = 3000$ rpm and 20 °C gearbox temperature)	T_{012}	Nm	1.7	1.4	1.3	1.2	1.3	1.3	1.4	1.4	1.4	1.3	1.3		
		in.lb	15	12	12	11	12	12	12	12	12	12	12		
Max. backlash	j_t	arcmin	Standard ≤ 5 / Reduced ≤ 3												
Torsional rigidity ^{b)}	C_{t21}	Nm/arcmin	16	16	20	21	23	24	15	23	19	22	27		
		in.lb/arcmin	142	142	177	186	204	212	133	204	168	195	239		
Tilting rigidity	C_{2K}	Nm/arcmin	225												
		in.lb/arcmin	1991												
Max. axial force ^{c)}	F_{2AMax}	N	2795												
		lb _f	629												
Max. tilting moment	M_{2KMax}	Nm	270												
		in.lb	2390												
Efficiency at full load	η	%	94												
Service life ¹⁾	L_h	h	> 20000												
Weight (incl. standard adapter plate)	m	kg	5.2												
		lb _m	11												
Operating noise (at reference ratio and reference speed – ratio-specific values available in cymex [®])	L_{PA}	dB(A)	≤ 66												
Max. permitted housing temperature		°C	+90												
		F	194												
Ambient temperature		°C	0 to +40												
		F	32 to 104												
Lubrication			Lubricated for life												
Direction of rotation			In- and output opposite direction												
Protection class			IP 65												
Metal bellows coupling (recommended product type – validate sizing with cymex [®])			BCT - 00060AAX - 050.000												
Bore diameter of coupling on the application side		mm	X = 014.000 - 035.000												
Mass moment of inertia (relates to the drive)	C	14	J_1	kgcm ²	0.55	0.46	0.44	0.39	0.43	0.36	0.34	0.37	0.34	0.34	0.34
				10 ⁻³ in.lb.s ²	0.49	0.41	0.39	0.35	0.38	0.32	0.3	0.33	0.3	0.3	0.3
Clamping hub diameter [mm]	E	19	J_1	kgcm ²	0.9	0.81	0.79	0.75	0.78	0.71	0.7	0.72	0.7	0.69	0.69
				10 ⁻³ in.lb.s ²	0.8	0.72	0.7	0.66	0.69	0.63	0.62	0.64	0.62	0.61	0.61

Please use our sizing software cymex[®] for a detailed sizing – www.wittenstein-cymex.com
Please contact us for optimum sizing at S1 conditions (Continuous operation).

- ^{a)} At max. 10 % M_{2KMax}
- ^{b)} Valid for standard clamping hub diameter
- ^{c)} Refers to center of the output shaft or flange
- ^{d)} Please reduce input speed at higher ambient temperatures
- ¹⁾ Please contact us to discuss application-specific service lifetimes

View A

Motor shaft diameter [mm]

2-stage

up to 14/19⁴⁾
(C⁵⁾ / E) clamping
hub diameter

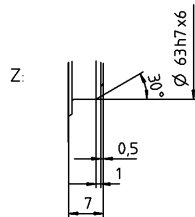
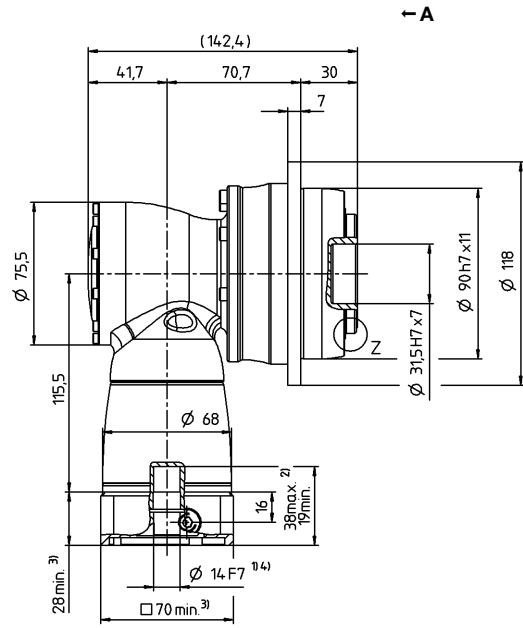
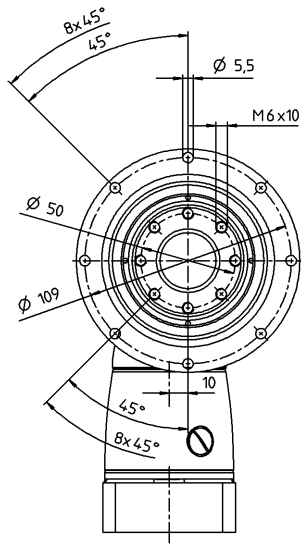

See technical data sheet for available clamping hub diameters (mass moment of inertia). Dimensions available on request.

- Non-tolerated dimensions are nominal dimensions
- ¹⁾ Check motor shaft fit
- ²⁾ Min./Max. permissible motor shaft length. Longer motor shafts are possible, please contact alpha.
- ³⁾ The dimensions depend on the motor
- ⁴⁾ Smaller motor shaft diameter is compensated by a bushing with a minimum wall thickness of 1 mm
- ⁵⁾ Standard clamping hub diameter

TPK+ 010 MF 3-stage

			3-stage													
Ratio	i		64	84	100	125	140	175	200	250	280	350	400	500	700	1000
Max. torque ^{a) b)}	T_{2a}	Nm	144	144	180	180	180	180	180	180	210	210	96	120	168	168
		in.lb	1275	1275	1593	1593	1593	1593	1593	1593	1859	1859	850	1062	1487	1487
Max. acceleration torque ^{b)} (max. 1000 cycles per hour)	T_{2B}	Nm	120	120	150	150	150	150	150	150	172	172	80	100	140	126
		in.lb	1062	1062	1328	1328	1328	1328	1328	1328	1522	1522	708	885	1239	1115
Nominal torque (at n_n)	T_{2N}	Nm	85	85	90	90	90	90	90	90	75	90	60	75	90	60
		in.lb	752	752	797	797	797	797	797	797	664	797	531	664	797	531
Emergency stop torque ^{a) b)} (permitted 1000 times during the service life of the gearbox)	T_{2Not}	Nm	200	160	250	250	250	250	250	250	251	251	160	200	251	251
		in.lb	1770	1416	2213	2213	2213	2213	2213	2213	2222	2222	1416	1770	2222	2222
Permitted average input speed (at T_{2a} and 20 °C ambient temperature) ^{d)}	n_{1N}	n_{1T}	4400	4400	4400	4400	4400	4400	4400	4800	4400	4800	5500	5500	5500	5500
Max. input speed	n_{1Max}	rpm	6000	6000	6000	6000	6000	6000	6000	6000	6000	6000	6000	6000	6000	6000
Mean no load running torque ^{b)} (at $n_i = 3000$ rpm and 20 °C gearbox temperature)	T_{012}	Nm	0.3	0.3	0.3	0.3	0.3	0.3	0.2	0.2	0.2	0.2	0.2	0.2	0.2	0.2
		in.lb	2.7	2.7	2.7	2.7	2.7	2.7	1.8	1.8	1.8	1.8	1.8	1.8	1.8	1.8
Max. backlash	j_t	arcmin	Standard ≤ 5 / Reduced ≤ 3													
Torsional rigidity ^{b)}	C_{t21}	Nm/arcmin	16	16	20	21	20	21	20	21	23	24	15	19	22	27
		in.lb/arcmin	142	142	177	186	177	186	177	186	204	212	133	168	195	239
Tilting rigidity	C_{2K}	Nm/arcmin	225													
		in.lb/arcmin	1991													
Max. axial force ^{c)}	F_{2AMax}	N	2795													
		lb _f	629													
Max. tilting moment	M_{2KMax}	Nm	270													
		in.lb	2390													
Efficiency at full load	η	%	92													
Service life ¹⁾	L_h	h	> 20000													
Weight (incl. standard adapter plate)	m	kg	5.5													
		lb _m	12													
Operating noise (at reference ratio and reference speed – ratio-specific values available in cymex [®])	L_{PA}	dB(A)	≤ 66													
Max. permitted housing temperature		°C	+90													
		F	194													
Ambient temperature		°C	0 to +40													
		F	32 to 104													
Lubrication			Lubricated for life													
Direction of rotation			In- and output opposite direction													
Protection class			IP 65													
Metal bellows coupling (recommended product type – validate sizing with cymex [®])			BCT - 00060AAX - 050.000													
Bore diameter of coupling on the application side		mm	X = 014.000 - 035.000													
Mass moment of inertia (relates to the drive)	B	11	J_1	kgcm ²	0.09	0.07	0.08	0.07	0.06	0.06	0.06	0.06	0.06	0.06	0.06	0.06
				10 ⁻³ in.lb.s ²	0.08	0.06	0.07	0.06	0.05	0.05	0.05	0.05	0.05	0.05	0.05	0.05
Clamping hub diameter [mm]	C	14	J_1	kgcm ²	0.2	0.18	0.19	0.19	0.18	0.18	0.17	0.17	0.17	0.17	0.17	0.17
				10 ⁻³ in.lb.s ²	0.18	0.16	0.17	0.17	0.16	0.16	0.15	0.15	0.15	0.15	0.15	0.15

Please use our sizing software cymex[®] for a detailed sizing – www.wittenstein-cymex.com
Please contact us for optimum sizing at S1 conditions (Continuous operation).

- ^{a)} At max. 10 % M_{2KMax}
- ^{b)} Valid for standard clamping hub diameter
- ^{c)} Refers to center of the output shaft or flange
- ^{d)} Please reduce input speed at higher ambient temperatures
- ¹⁾ Please contact us to discuss application-specific service lifetimes

View A

Motor shaft diameter [mm]

3-stage

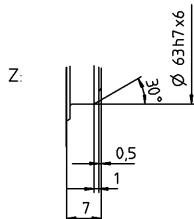
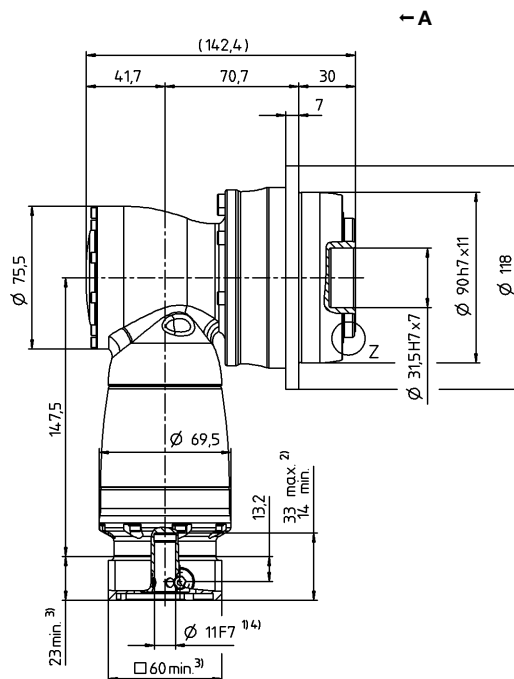
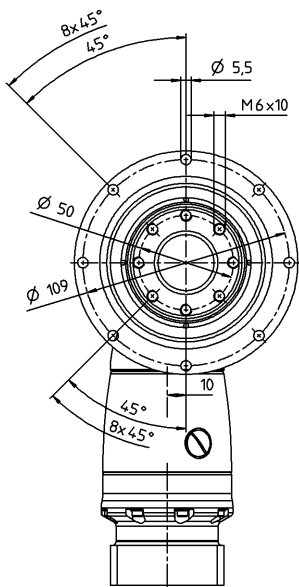
 up to 11/14⁴⁾
 (B⁵⁾/C) clamping
 hub diameter

See technical data sheet for available clamping hub diameters (mass moment of inertia). Dimensions available on request.

Non-tolerated dimensions are nominal dimensions

- ¹⁾ Check motor shaft fit
- ²⁾ Min./Max. permissible motor shaft length. Longer motor shafts are possible, please contact alpha.
- ³⁾ The dimensions depend on the motor
- ⁴⁾ Smaller motor shaft diameter is compensated by a bushing with a minimum wall thickness of 1 mm
- ⁵⁾ Standard clamping hub diameter

TPK+ 025 MF 2-stage

			2-stage											
Ratio	<i>i</i>		12	16	20	25	28	35	40	49	50	70	100	
Max. torque ^{a) b)}	T_{2a}	Nm	336	336	380	380	352	352	200	352	250	350	352	
		in.lb	2974	2974	3363	3363	3115	3115	1770	3115	2213	3098	3115	
Max. acceleration torque ^{b)} (max. 1000 cycles per hour)	T_{2B}	Nm	280	280	350	350	352	352	200	352	250	350	318	
		in.lb	2478	2478	3098	3098	3115	3115	1770	3115	2213	3098	2815	
Nominal torque (at n_n)	T_{2N}	Nm	170	170	170	170	170	170	160	170	170	170	120	
		in.lb	1505	1505	1505	1505	1505	1505	1416	1505	1505	1505	1062	
Emergency stop torque ^{a) b)} (permitted 1000 times during the service life of the gearbox)	T_{2Not}	Nm	380	460	575	575	625	625	400	625	500	625	625	
		in.lb	3363	4071	5089	5089	5532	5532	3540	5532	4425	5532	5532	
Permitted average input speed (at T_{2a} and 20 °C ambient temperature) ^{d)}	n_{1N}	n_{1T}	2000	2400	2400	2700	2400	2500	2500	2500	2500	2500	2500	
Max. input speed	n_{1Max}	rpm	7500	7500	7500	7500	7500	7500	7500	7500	7500	7500	7500	
Mean no load running torque ^{b)} (at $n_1 = 3000$ rpm and 20 °C gearbox temperature)	T_{012}	Nm	2.5	2.1	2	1.8	2	2.2	2	2.2	2	2	2	
		in.lb	22	19	18	16	18	19	18	19	18	18	18	
Max. backlash	j_t	arcmin	Standard ≤ 4 / Reduced ≤ 2											
Torsional rigidity ^{b)}	C_{t21}	Nm/arcmin	40	42	53	55	59	60	44	60	55	60	56	
		in.lb/arcmin	354	372	469	487	522	531	389	531	487	531	496	
Tilting rigidity	C_{2K}	Nm/arcmin	550											
		in.lb/arcmin	4868											
Max. axial force ^{c)}	F_{2AMax}	N	4800											
		lb _f	1080											
Max. tilting moment	M_{2KMax}	Nm	440											
		in.lb	3894											
Efficiency at full load	η	%	94											
Service life ¹⁾	L_h	h	> 20000											
Weight (incl. standard adapter plate)	m	kg	9											
		lb _m	20											
Operating noise (at reference ratio and reference speed – ratio-specific values available in cymex [®])	L_{PA}	dB(A)	≤ 68											
		°C	+90											
Max. permitted housing temperature		F	194											
		°C	0 to +40											
Ambient temperature		F	32 to 104											
Lubrication			Lubricated for life											
Direction of rotation			In- and output opposite direction											
Protection class			IP 65											
Metal bellows coupling (recommended product type – validate sizing with cymex [®])			BCT - 00150AAX - 063.000											
Bore diameter of coupling on the application side		mm	X = 019.000 - 042.000											
Mass moment of inertia (relates to the drive)	E	19	J_1	kgcm ²	1.43	1.18	1.16	1.04	1.14	0.94	0.89	0.95	0.89	0.89
				10 ⁻³ in.lb.s ²	1.27	1.04	1.03	0.92	1.01	0.83	0.79	0.84	0.79	0.79
Clamping hub diameter [mm]	H	28	J_1	kgcm ²	2.85	2.59	2.57	2.45	2.56	2.4	2.31	2.37	2.3	2.3
				10 ⁻³ in.lb.s ²	2.52	2.29	2.27	2.17	2.27	2.12	2.04	2.1	2.04	2.04

Please use our sizing software cymex[®] for a detailed sizing – www.wittenstein-cymex.com
Please contact us for optimum sizing at S1 conditions (Continuous operation).

- ^{a)} At max. 10 % M_{2KMax}
- ^{b)} Valid for standard clamping hub diameter
- ^{c)} Refers to center of the output shaft or flange
- ^{d)} Please reduce input speed at higher ambient temperatures
- ¹⁾ Please contact us to discuss application-specific service lifetimes

View A

Motor shaft diameter [mm]

2-stage

up to 19/28⁴⁾
(E⁵⁾/H) clamping
hub diameter

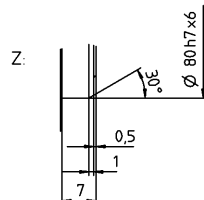
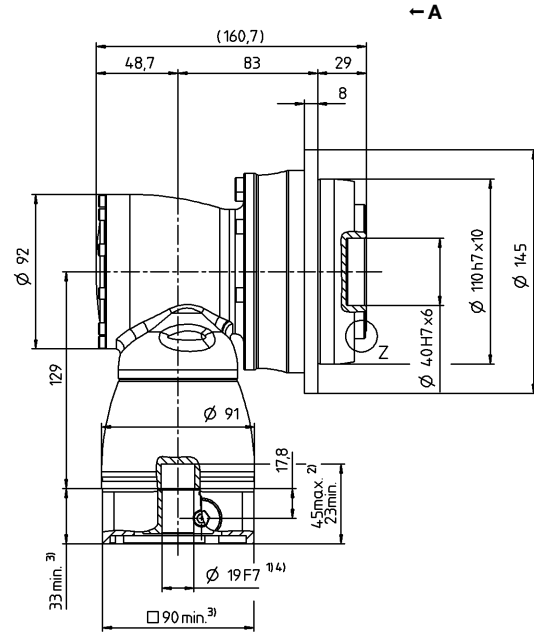
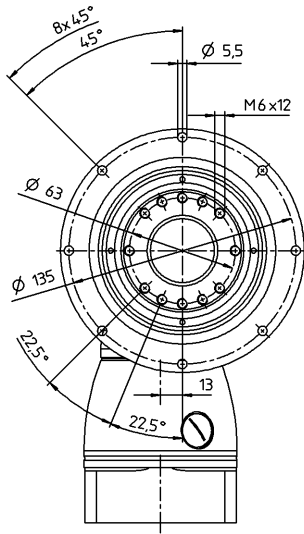

See technical data sheet for available clamping hub diameters (mass moment of inertia). Dimensions available on request.

- Non-tolerated dimensions are nominal dimensions
- ¹⁾ Check motor shaft fit
- ²⁾ Min./Max. permissible motor shaft length. Longer motor shafts are possible, please contact alpha.
- ³⁾ The dimensions depend on the motor
- ⁴⁾ Smaller motor shaft diameter is compensated by a bushing with a minimum wall thickness of 1 mm
- ⁵⁾ Standard clamping hub diameter

TPK+ 025 MF 3-stage

			3-stage														
Ratio	<i>i</i>		64	84	100	125	140	175	200	250	280	350	400	500	700	1000	
Max. torque ^{a) b)}	T_{2a}	Nm	336	336	380	380	380	380	380	380	352	352	240	300	352	352	
		in.lb	2974	2974	3363	3363	3363	3363	3363	3363	3115	3115	2124	2655	3115	3115	
Max. acceleration torque ^{b)} (max. 1000 cycles per hour)	T_{2B}	Nm	280	280	350	350	350	350	350	350	352	352	200	250	350	318	
		in.lb	2478	2478	3098	3098	3098	3098	3098	3098	3115	3115	1770	2213	3098	2815	
Nominal torque (at n_n)	T_{2N}	Nm	200	170	200	200	200	200	200	200	210	200	160	200	200	120	
		in.lb	1770	1505	1770	1770	1770	1770	1770	1770	1859	1770	1416	1770	1770	1062	
Emergency stop torque ^{a) b)} (permitted 1000 times during the service life of the gearbox)	T_{2Not}	Nm	460	380	575	575	575	575	575	575	625	625	400	500	625	625	
		in.lb	4071	3363	5089	5089	5089	5089	5089	5089	5532	5532	3540	4425	5532	5532	
Permitted average input speed (at T_{2a} and 20 °C ambient temperature) ^{d)}	n_{1N}	n_{1T}	3500	3500	3500	3500	3500	3500	3500	3800	3500	3800	4500	4500	4500	4500	
Max. input speed	n_{1Max}	rpm	6000	6000	6000	6000	6000	6000	6000	6000	6000	6000	6000	6000	6000	6000	
Mean no load running torque ^{b)} (at $n_i = 3000$ rpm and 20 °C gearbox temperature)	T_{012}	Nm	0.6	0.45	0.45	0.45	0.45	0.45	0.3	0.3	0.3	0.3	0.3	0.3	0.3	0.3	
		in.lb	5.3	4.0	4.0	4.0	4.0	4.0	4.0	2.7	2.7	2.7	2.7	2.7	2.7	2.7	
Max. backlash	j_t	arcmin	Standard ≤ 4 / Reduced ≤ 2														
Torsional rigidity ^{b)}	C_{121}	Nm/arcmin	42	40	53	55	53	55	53	55	59	60	44	55	60	56	
		in.lb/arcmin	372	354	469	487	469	487	469	487	522	531	389	487	531	496	
Tilting rigidity	C_{2K}	Nm/arcmin	550														
		in.lb/arcmin	4868														
Max. axial force ^{c)}	F_{2AMax}	N	4800														
		lb _f	1080														
Max. tilting moment	M_{2KMax}	Nm	440														
		in.lb	3894														
Efficiency at full load	η	%	92														
Service life ¹⁾	L_h	h	> 20000														
Weight (incl. standard adapter plate)	m	kg	9.8														
		lb _m	22														
Operating noise (at reference ratio and reference speed – ratio-specific values available in cymex [®])	L_{PA}	dB(A)	≤ 68														
		°C	+90														
Max. permitted housing temperature	F	°C	194														
		F	32 to 104														
Ambient temperature		°C	0 to +40														
		F	32 to 104														
Lubrication			Lubricated for life														
Direction of rotation			In- and output opposite direction														
Protection class			IP 65														
Metal bellows coupling (recommended product type – validate sizing with cymex [®])			BCT - 00150AAX - 063.000														
Bore diameter of coupling on the application side		mm	X = 019.000 - 042.000														
Mass moment of inertia (relates to the drive)	C	14	J_1	kgcm ²	0.28	0.23	0.24	0.23	0.21	0.2	0.19	0.18	0.19	0.18	0.18	0.18	0.18
				10 ⁻³ in.lb.s ²	0.25	0.2	0.21	0.2	0.19	0.18	0.17	0.16	0.17	0.16	0.16	0.16	0.16
Clamping hub diameter [mm]	E	19	J_1	kgcm ²	0.72	0.63	0.68	0.68	0.63	0.63	0.63	0.63	0.63	0.63	0.63	0.63	
				10 ⁻³ in.lb.s ²	0.64	0.56	0.6	0.6	0.56	0.56	0.56	0.56	0.56	0.56	0.56	0.56	0.56

Please use our sizing software cymex[®] for a detailed sizing – www.wittenstein-cymex.com
Please contact us for optimum sizing at S1 conditions (Continuous operation).

- ^{a)} At max. 10 % M_{2KMax}
- ^{b)} Valid for standard clamping hub diameter
- ^{c)} Refers to center of the output shaft or flange
- ^{d)} Please reduce input speed at higher ambient temperatures
- ¹⁾ Please contact us to discuss application-specific service lifetimes

View A

Motor shaft diameter [mm]

3-stage

up to 14/19⁴⁾
(C⁵⁾/E) clamping
hub diameter

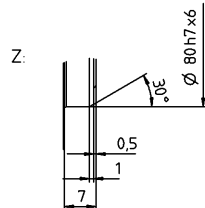
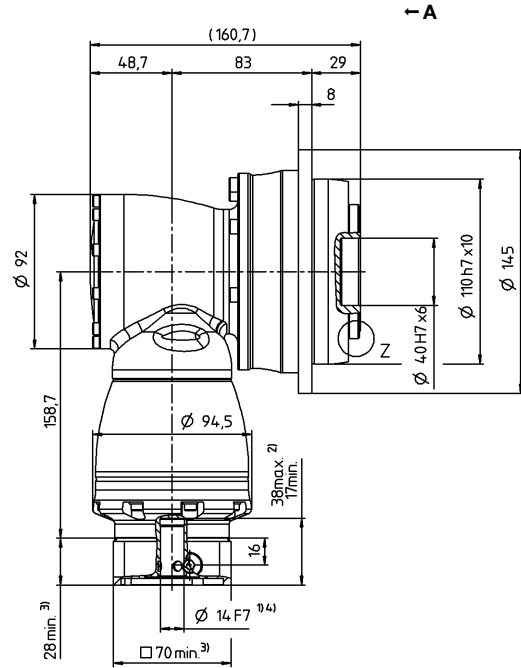
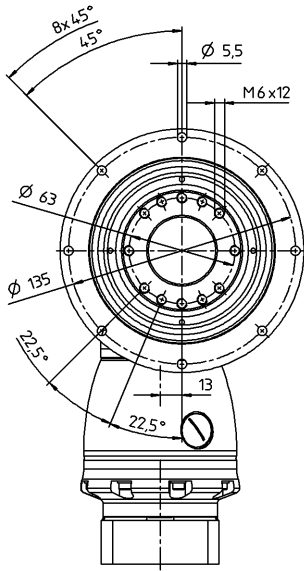

See technical data sheet for available clamping hub diameters (mass moment of inertia). Dimensions available on request.

- Non-tolerated dimensions are nominal dimensions
- ¹⁾ Check motor shaft fit
- ²⁾ Min./Max. permissible motor shaft length. Longer motor shafts are possible, please contact alpha.
- ³⁾ The dimensions depend on the motor
- ⁴⁾ Smaller motor shaft diameter is compensated by a bushing with a minimum wall thickness of 1 mm
- ⁵⁾ Standard clamping hub diameter

TPK+ 050 MF 2-stage

			2-stage												
Ratio	<i>i</i>		12	16	20	25	28	35	40	49	50	70	100		
Max. torque ^{a) b)}	T_{2a}	Nm	816	816	992	992	868	868	500	868	625	868	720		
		in.lb	7222	7222	8780	8780	7682	7682	4425	7682	5532	7682	6373		
Max. acceleration torque ^{b)} (max. 1000 cycles per hour)	T_{2B}	Nm	680	680	840	840	840	840	500	840	625	840	648		
		in.lb	6019	6019	7435	7435	7435	7435	4425	7435	5532	7435	5735		
Nominal torque (at n_n)	T_{2N}	Nm	370	370	370	370	370	370	320	370	370	370	240		
		in.lb	3275	3275	3275	3275	3275	3275	2832	3275	3275	3275	2124		
Emergency stop torque ^{a) b)} (permitted 1000 times during the service life of the gearbox)	T_{2Not}	Nm	880	1040	1250	1250	1250	1250	1000	1250	1250	1250	1250		
		in.lb	7789	9205	11064	11064	11064	11064	8851	11064	11064	11064	11064		
Permitted average input speed (at T_{2a} and 20 °C ambient temperature) ^{d)}	n_{1N}	n_{1T}	1900	2300	2300	2600	2300	2300	2300	2300	2300	2300	2300		
Max. input speed	n_{1Max}	rpm	5500	5500	5500	5500	5500	5500	5500	5500	5500	5500	5500		
Mean no load running torque ^{b)} (at $n_i = 3000$ rpm and 20 °C gearbox temperature)	T_{012}	Nm	5.6	4.3	4.2	3.4	4.1	4.7	3.3	4.1	3.3	3.3	3.3		
		in.lb	50	38	37	30	36	42	29	36	29	29	29		
Max. backlash	j_t	arcmin	Standard ≤ 4 / Reduced ≤ 2												
Torsional rigidity ^{b)}	C_{t21}	Nm/arcmin	87	91	111	119	123	127	96	127	115	125	112		
		in.lb/arcmin	770	805	982	1053	1089	1124	850	1124	1018	1106	991		
Tilting rigidity	C_{2K}	Nm/arcmin	560												
		in.lb/arcmin	4956												
Max. axial force ^{c)}	F_{2AMax}	N	6130												
		lb _f	1379												
Max. tilting moment	M_{2KMax}	Nm	1335												
		in.lb	11816												
Efficiency at full load	η	%	94												
Service life ^{f)}	L_h	h	> 20000												
Weight (incl. standard adapter plate)	m	kg	17												
		lb _m	38												
Operating noise (at reference ratio and reference speed – ratio-specific values available in cymex [®])	L_{PA}	dB(A)	≤ 68												
		°C	+90												
Max. permitted housing temperature		F	194												
		°C	0 to +40												
Ambient temperature		F	32 to 104												
Lubrication			Lubricated for life												
Direction of rotation			In- and output opposite direction												
Protection class			IP 65												
Metal bellows coupling (recommended product type – validate sizing with cymex [®])			BCT - 00300AAX - 080.000												
		mm	X = 024.000 - 060.000												
Mass moment of inertia (relates to the drive)	H	28	J_1	kgcm ²	4.56	3.76	3.71	3.28	3.66	3	2.79	3.1	2.78	2.77	2.77
				10 ⁻³ in.lb.s ²	4.04	3.33	3.28	2.9	3.24	2.66	2.47	2.74	2.46	2.45	2.45
Clamping hub diameter [mm]	K	38	J_1	kgcm ²	11.7	10.9	10.9	10.4	10.8	10.3	9.95	10.4	9.94	9.94	9.94
				10 ⁻³ in.lb.s ²	10.35	9.65	9.65	9.2	9.56	9.12	8.81	9.2	8.8	8.8	8.8

Please use our sizing software cymex[®] for a detailed sizing – www.wittenstein-cymex.com
Please contact us for optimum sizing at S1 conditions (Continuous operation).

- ^{a)} At max. 10 % M_{2KMax}
- ^{b)} Valid for standard clamping hub diameter
- ^{c)} Refers to center of the output shaft or flange
- ^{d)} Please reduce input speed at higher ambient temperatures
- ^{f)} Please contact us to discuss application-specific service lifetimes

View A

Motor shaft diameter [mm]

2-stage

up to 28/38⁴⁾
(H⁵⁾/K) clamping
hub diameter

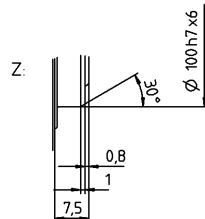
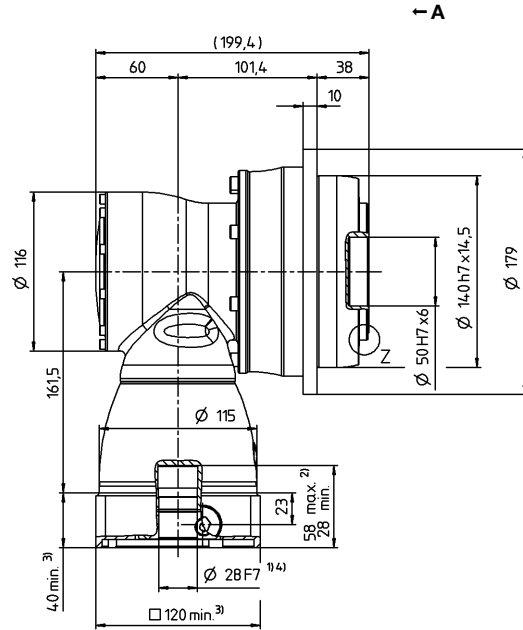
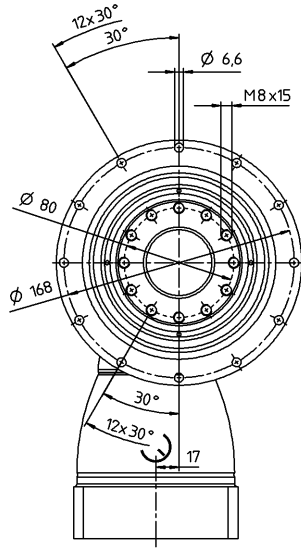

See technical data sheet for available clamping hub diameters (mass moment of inertia). Dimensions available on request.

Non-tolerated dimensions are nominal dimensions
¹⁾ Check motor shaft fit

²⁾ Min./Max. permissible motor shaft length. Longer motor shafts are possible, please contact alpha.

³⁾ The dimensions depend on the motor

⁴⁾ Smaller motor shaft diameter is compensated by a bushing with a minimum wall thickness of 1 mm

⁵⁾ Standard clamping hub diameter

TPK+ 050 MF 3-stage

			3-stage													
Ratio	<i>i</i>		64	84	100	125	140	175	200	250	280	350	400	500	700	1000
Max. torque ^{a) b)}	T_{2a}	Nm	816	816	992	992	992	992	992	992	868	868	600	750	868	720
		in.lb	7222	7222	8780	8780	8780	8780	8780	8780	8780	7682	7682	5310	6638	7682
Max. acceleration torque ^{b)} (max. 1000 cycles per hour)	T_{2B}	Nm	680	680	840	840	840	840	840	840	840	840	500	625	840	648
		in.lb	6019	6019	7435	7435	7435	7435	7435	7435	7435	7435	4425	5532	7435	5735
Nominal torque (at n_n)	T_{2N}	Nm	400	400	400	400	400	400	400	400	400	400	320	370	400	240
		in.lb	3540	3540	3540	3540	3540	3540	3540	3540	3540	3540	2832	3275	3540	2124
Emergency stop torque ^{a) b)} (permitted 1000 times during the service life of the gearbox)	T_{2Not}	Nm	1040	880	1250	1250	1250	1250	1250	1250	1250	1250	1000	1250	1250	1250
		in.lb	9205	7789	11064	11064	11064	11064	11064	11064	11064	11064	8851	11064	11064	11064
Permitted average input speed (at T_{2a} and 20 °C ambient temperature) ^{d)}	n_{1N}	n_{1T}	3100	3100	3100	3100	3100	3100	3100	3500	3100	3500	4200	4200	4200	4200
Max. input speed	n_{1Max}	rpm	4500	4500	4500	4500	4500	4500	4500	4500	4500	4500	4500	4500	4500	4500
Mean no load running torque ^{b)} (at $n_i = 3000$ rpm and 20 °C gearbox temperature)	T_{012}	Nm	1.1	0.9	0.9	0.75	0.75	0.6	0.45	0.45	0.45	0.45	0.45	0.45	0.45	0.45
		in.lb	9.7	8.0	8.0	6.6	6.6	5.3	4.0	4.0	4.0	4.0	4.0	4.0	4.0	4.0
Max. backlash	j_t	arcmin	Standard ≤ 4 / Reduced ≤ 2													
Torsional rigidity ^{b)}	C_{t21}	Nm/arcmin	91	87	111	119	111	119	111	119	123	127	95	115	125	112
		in.lb/arcmin	805	770	982	1053	982	1053	982	1053	1089	1124	841	1018	1106	991
Tilting rigidity	C_{2K}	Nm/arcmin	560													
		in.lb/arcmin	4956													
Max. axial force ^{c)}	F_{2AMax}	N	6130													
		lb _f	1379													
Max. tilting moment	M_{2KMax}	Nm	1335													
		in.lb	11816													
Efficiency at full load	η	%	92													
Service life ¹⁾	L_h	h	> 20000													
Weight (incl. standard adapter plate)	m	kg	18.7													
		lb _m	41													
Operating noise (at reference ratio and reference speed – ratio-specific values available in cymex [®])	L_{PA}	dB(A)	≤ 68													
		°C	+90													
Max. permitted housing temperature		F	194													
		°C	0 to +40													
Ambient temperature		F	32 to 104													
Lubrication			Lubricated for life													
Direction of rotation			In- and output opposite direction													
Protection class			IP 65													
Metal bellows coupling (recommended product type – validate sizing with cymex [®])			BCT - 00300AAX - 080.000													
Bore diameter of coupling on the application side		mm	X = 024.000 - 060.000													
Mass moment of inertia (relates to the drive)	E 19	J_1	kgcm ²	1.01	0.76	0.88	0.85	0.76	0.75	0.7	0.69	0.7	0.69	0.69	0.69	0.69
			10 ⁻³ in.lb.s ²	0.89	0.67	0.78	0.75	0.67	0.66	0.62	0.61	0.62	0.61	0.61	0.61	0.61
Clamping hub diameter [mm]	G 24	J_1	kgcm ²	2.57	2.32	2.44	2.42	2.32	2.31	2.26	2.25	2.26	2.25	2.25	2.25	2.25
			10 ⁻³ in.lb.s ²	2.27	2.05	2.16	2.14	2.05	2.04	2	1.99	2	1.99	1.99	1.99	1.99

Please use our sizing software cymex[®] for a detailed sizing – www.wittenstein-cymex.com
Please contact us for optimum sizing at S1 conditions (Continuous operation).

- ^{a)} At max. 10 % M_{2KMax}
- ^{b)} Valid for standard clamping hub diameter
- ^{c)} Refers to center of the output shaft or flange
- ^{d)} Please reduce input speed at higher ambient temperatures
- ¹⁾ Please contact us to discuss application-specific service lifetimes

View A

Motor shaft diameter [mm]

3-stage

up to 19/24⁴⁾
(E⁵⁾/G) clamping
hub diameter

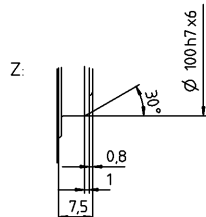
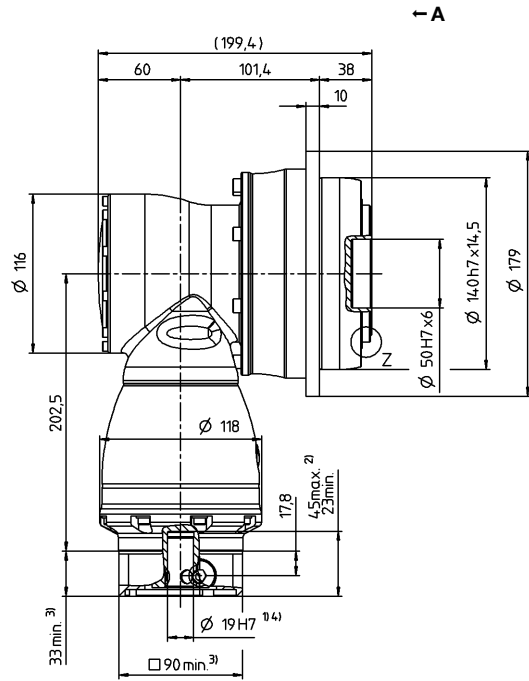
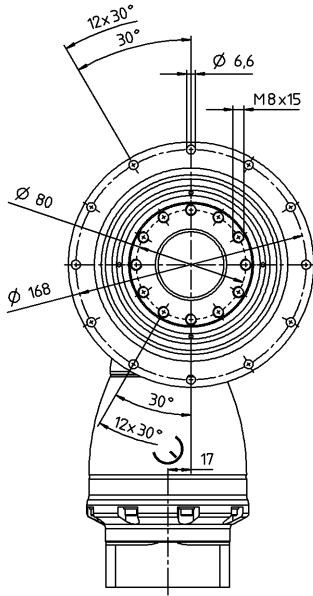

See technical data sheet for available clamping hub diameters (mass moment of inertia). Dimensions available on request.

Non-tolerated dimensions are nominal dimensions
1) Check motor shaft fit

2) Min./Max. permissible motor shaft length. Longer motor shafts are possible, please contact alpha.

3) The dimensions depend on the motor

4) Smaller motor shaft diameter is compensated by a bushing with a minimum wall thickness of 1 mm

5) Standard clamping hub diameter

Hypoid gearboxes

TPK+

MF

TPK+ 110 MF 2-stage

			2-stage												
Ratio	i		12	16	20	25	28	35	40	49	50	70	100		
Max. torque ^{a) b)}	T_{2a}	Nm	1440	1440	1800	1800	2520	2520	840	1750	1050	1470	2100		
		in.lb	12745	12745	15931	15931	22304	22304	7435	15489	9293	13011	18587		
Max. acceleration torque ^{b)} (max. 1000 cycles per hour)	T_{2B}	Nm	1200	1200	1500	1500	1920	1920	840	1750	1050	1470	1680		
		in.lb	10621	10621	13276	13276	16994	16994	7435	15489	9293	13011	14869		
Nominal torque (at n_N)	T_{2N}	Nm	700	700	750	750	750	750	640	750	750	750	750		
		in.lb	6196	6196	6638	6638	6638	6638	5665	6638	6638	6638	6638		
Emergency stop torque ^{a) b)} (permitted 1000 times during the service life of the gearbox)	T_{2Not}	Nm	1600	2000	2500	2500	3075	3075	1600	3075	2000	2800	3075		
		in.lb	14161	17702	22127	22127	27216	27216	14161	27216	17702	24782	27216		
Permitted average input speed (at T_{2a} and 20 °C ambient temperature) ^{d)}	n_{1N}	n_{1T}	1600	1900	1900	2100	1900	2100	2100	2100	2100	2100	2100		
Max. input speed	n_{1Max}	rpm	5000	5000	5000	5000	5000	5000	5000	5000	5000	5000	5000		
Mean no load running torque ^{b)} (at $n_1 = 3000$ rpm and 20 °C gearbox temperature)	T_{012}	Nm	12	8.9	8.9	5.5	8.2	8	7.5	10	7.5	7.4	7.4		
		in.lb	106	79	79	49	73	71	66	89	66	65	65		
Max. backlash	j_t	arcmin	Standard ≤ 4 / Reduced ≤ 2												
Torsional rigidity ^{b)}	C_{t21}	Nm/arcmin	253	269	336	346	400	407	274	410	341	404	389		
		in.lb/arcmin	2239	2381	2974	3062	3540	3602	2425	3629	3018	3576	3443		
Tilting rigidity	C_{2K}	Nm/arcmin	1452												
		in.lb/arcmin	12851												
Max. axial force ^{c)}	F_{2AMax}	N	10050												
		lb _f	2261												
Max. tilting moment	M_{2KMax}	Nm	3280												
		in.lb	29030												
Efficiency at full load	η	%	94												
Service life ^{f)}	L_h	h	> 20000												
Weight (incl. standard adapter plate)	m	kg	41												
		lb _m	91												
Operating noise (at reference ratio and reference speed – ratio-specific values available in cymex [®])	L_{PA}	dB(A)	≤ 70												
		°C	+90												
Max. permitted housing temperature		F	194												
		°C	0 to +40												
Ambient temperature		F	32 to 104												
Lubrication			Lubricated for life												
Direction of rotation			In- and output opposite direction												
Protection class			IP 65												
Metal bellows coupling (recommended product type – validate sizing with cymex [®])			BCT - 01500AAX - 125.000												
Bore diameter of coupling on the application side		mm	X = 050.000 - 080.000												
Mass moment of inertia (relates to the drive) Clamping hub diameter [mm]	K	38	J_1	kgcm ²	24.3	19	18.7	16.1	18.5	15.7	12.8	17.5	12.7	12.7	12.7
				10 ⁻³ in.lb.s ²	21.51	16.82	16.55	14.25	16.37	13.89	11.33	15.49	11.24	11.24	11.24

Please use our sizing software cymex[®] for a detailed sizing – www.wittenstein-cymex.com
Please contact us for optimum sizing at S1 conditions (Continuous operation).

- ^{a)} At max. 10 % M_{2KMax}
- ^{b)} Valid for standard clamping hub diameter
- ^{c)} Refers to center of the output shaft or flange
- ^{d)} Please reduce input speed at higher ambient temperatures
- ^{f)} Please contact us to discuss application-specific service lifetimes

View A

Motor shaft diameter [mm]

2-stage

up to 38⁴⁾ (K)⁵⁾
clamping hub diameter

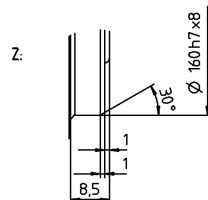
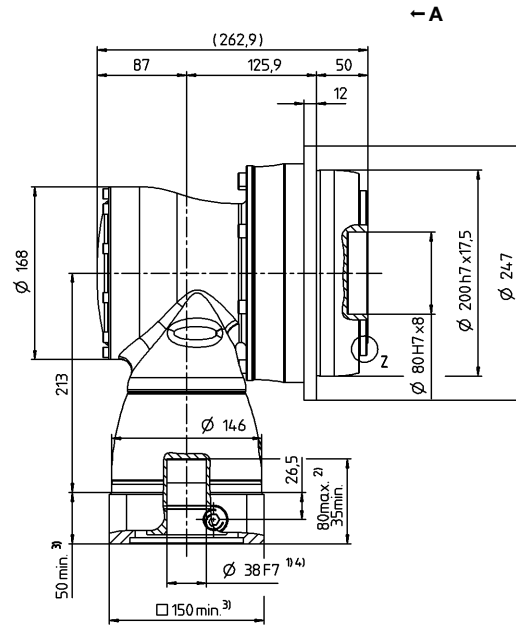
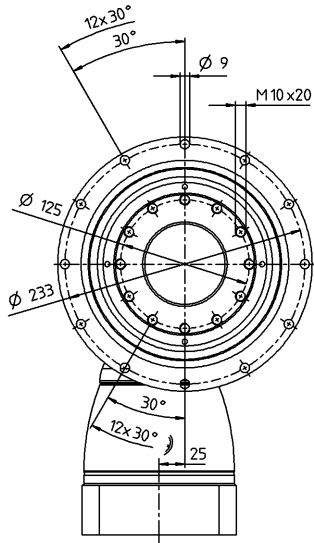

See technical data sheet for available clamping hub diameters (mass moment of inertia). Dimensions available on request.

- Non-tolerated dimensions are nominal dimensions
- ¹⁾ Check motor shaft fit
- ²⁾ Min./Max. permissible motor shaft length. Longer motor shafts are possible, please contact alpha.
- ³⁾ The dimensions depend on the motor
- ⁴⁾ Smaller motor shaft diameter is compensated by a bushing with a minimum wall thickness of 1 mm
- ⁵⁾ Standard clamping hub diameter

TPK+ 110 MF 3-stage

				3-stage													
Ratio	i			64	84	100	125	140	175	200	250	280	350	400	500	700	1000
Max. torque ^{a) b)}	T_{2a}	Nm		1440	1440	1800	1800	1800	1800	1800	1800	2520	2520	1008	1260	1764	2240
		in.lb		12745	12745	15931	15931	15931	15931	15931	15931	15931	22304	22304	8922	11152	15613
Max. acceleration torque ^{b)} (max. 1000 cycles per hour)	T_{2B}	Nm		1200	1200	1500	1500	1500	1500	1500	1500	1920	1920	840	1050	1470	1680
		in.lb		10621	10621	13276	13276	13276	13276	13276	13276	13276	16994	16994	7435	9293	13011
Nominal torque (at n_n)	T_{2N}	Nm		700	700	950	950	950	950	950	950	1120	1250	640	750	1120	800
		in.lb		6196	6196	8408	8408	8408	8408	8408	8408	8408	9913	11064	5665	6638	9913
Emergency stop torque ^{a) b)} (permitted 1000 times during the service life of the gearbox)	T_{2Not}	Nm		2000	1600	2500	2500	2500	2500	2500	2500	3075	3075	1600	2000	2800	3075
		in.lb		17702	14161	22127	22127	22127	22127	22127	22127	22127	27216	27216	14161	17702	24782
Permitted average input speed (at T_{2a} and 20 °C ambient temperature) ^{d)}	n_{1N}	n_{1T}		2900	2900	2900	2900	2900	2900	2900	3200	2900	3200	3900	3900	3900	3900
Max. input speed	n_{1Max}	rpm		4500	4500	4500	4500	4500	4500	4500	4500	4500	4500	4500	4500	4500	4500
Mean no load running torque ^{b)} (at $n_i = 3000$ rpm and 20 °C gearbox temperature)	T_{012}	Nm		3	1.5	2.4	1.8	1.8	1.5	1.5	1.2	1.5	1.2	1.2	1.2	1.2	1.2
		in.lb		27	13	21	16	16	13	13	11	13	11	11	11	11	11
Max. backlash	j_t	arcmin		Standard ≤ 4 / Reduced ≤ 2													
Torsional rigidity ^{b)}	C_{t21}	Nm/arcmin		269	252	336	346	336	346	336	346	400	407	274	341	404	389
		in.lb/arcmin		2381	2230	2974	3062	2974	3062	2974	3062	3540	3602	2425	3018	3576	3443
Tilting rigidity	C_{2K}	Nm/arcmin		1452													
		in.lb/arcmin		12851													
Max. axial force ^{c)}	F_{2AMax}	N		10050													
		lb _f		2261													
Max. tilting moment	M_{2KMax}	Nm		3280													
		in.lb		29030													
Efficiency at full load	η	%		92													
Service life ^{f)}	L_h	h		> 20000													
Weight (incl. standard adapter plate)	m	kg		45.4													
		lb _m		100													
Operating noise (at reference ratio and reference speed – ratio-specific values available in cymex [®])	L_{PA}	dB(A)		≤ 70													
		°C		+90													
Max. permitted housing temperature		F		194													
		°C		0 to +40													
Ambient temperature		F		32 to 104													
		°C															
Lubrication				Lubricated for life													
Direction of rotation				In- and output opposite direction													
Protection class				IP 65													
Metal bellows coupling (recommended product type – validate sizing with cymex [®])				BCT - 01500AAX - 125.000													
Bore diameter of coupling on the application side		mm		X = 050.000 - 080.000													
Mass moment of inertia (relates to the drive)	G	24	J_1	kgcm ²	3.97	2.82	3.36	3.22	2.82	2.75	2.5	2.47	2.5	2.44	2.42	2.42	2.42
				10 ⁻³ in.lb.s ²	3.51	2.5	2.97	2.85	2.5	2.43	2.21	2.19	2.21	2.16	2.14	2.14	2.14
Clamping hub diameter [mm]	K	38	J_1	kgcm ²	10.9	9.74	10.3	10.1	9.74	9.66	9.41	9.38	9.41	9.38	9.33	9.33	9.33
				10 ⁻³ in.lb.s ²	9.65	8.62	9.12	8.94	8.62	8.55	8.33	8.3	8.33	8.3	8.26	8.26	8.26

Please use our sizing software cymex[®] for a detailed sizing – www.wittenstein-cymex.com
Please contact us for optimum sizing at S1 conditions (Continuous operation).

- ^{a)} At max. 10 % M_{2KMax}
- ^{b)} Valid for standard clamping hub diameter
- ^{c)} Refers to center of the output shaft or flange
- ^{d)} Please reduce input speed at higher ambient temperatures
- ^{f)} Please contact us to discuss application-specific service lifetimes

View A

Motor shaft diameter [mm]

3-stage

up to 24 / 38⁴⁾
(G⁵⁾ / K) clamping
hub diameter

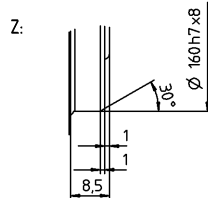
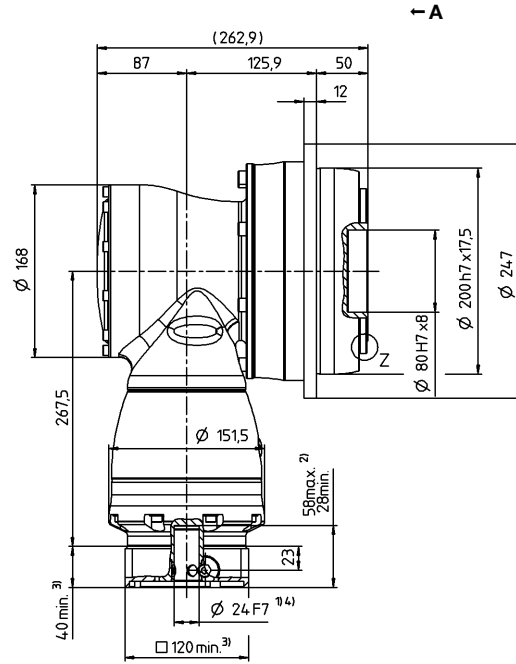
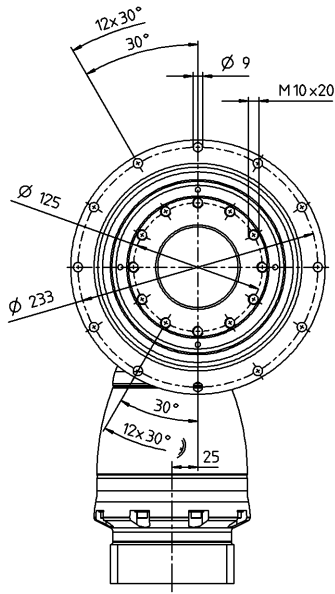

See technical data sheet for available clamping hub diameters (mass moment of inertia). Dimensions available on request.

- Non-tolerated dimensions are nominal dimensions
- ¹⁾ Check motor shaft fit
- ²⁾ Min./Max. permissible motor shaft length. Longer motor shafts are possible, please contact alpha.
- ³⁾ The dimensions depend on the motor
- ⁴⁾ Smaller motor shaft diameter is compensated by a bushing with a minimum wall thickness of 1 mm
- ⁵⁾ Standard clamping hub diameter

TPK+ 300 MF 2-stage

			2-stage									
Ratio	<i>i</i>		15	20	25	35	49	50	70	100		
Max. torque ^{a) b)}	T_{2a}	Nm	3840	3840	3840	5250	3840	2350	3290	2800		
		in.lb	33987	33987	33987	46467	33987	20799	29119	24782		
Max. acceleration torque ^{b)} (max. 1000 cycles per hour)	T_{2B}	Nm	3200	3200	3200	3960	3850	2350	3290	2280		
		in.lb	28323	28323	28323	35049	34076	20799	29119	20180		
Nominal torque (at n_n)	T_{2N}	Nm	2000	2000	2000	1800	1800	1800	1800	1600		
		in.lb	17702	17702	17702	15931	15931	15931	15931	14161		
Emergency stop torque ^{a) b)} (permitted 1000 times during the service life of the gearbox)	T_{2Not}	Nm	4500	5250	5250	7350	6790	4500	6300	8750		
		in.lb	39829	46467	46467	65053	60097	39829	55760	77445		
Permitted average input speed (at T_{2a} and 20 °C ambient temperature) ^{d)}	n_{1N}	n_{1T}	1500	1700	1900	1900	1700	1700	1700	1700		
Max. input speed	n_{1Max}	rpm	4500	4500	4500	4500	4500	4500	4500	4500		
Mean no load running torque ^{b)} (at $n_1 = 3000$ rpm and 20 °C gearbox temperature)	T_{012}	Nm	24	19	15	14	17	21	17	16		
		in.lb	212	168	133	124	150	186	150	142		
Max. backlash	j_t	arcmin	Standard ≤ 4 / Reduced ≤ 2									
Torsional rigidity ^{b)}	C_{t21}	Nm/arcmin	615	640	664	730	728	658	727	642		
		in.lb/arcmin	5443	5665	5877	6461	6443	5824	6435	5682		
Tilting rigidity	C_{2K}	Nm/arcmin	5560									
		in.lb/arcmin	49210									
Max. axial force ^{c)}	F_{2AMax}	N	33000									
		lb _f	7425									
Max. tilting moment	M_{2KMax}	Nm	5900									
		in.lb	52220									
Efficiency at full load	η	%	94									
Service life ^{f)}	L_h	h	> 20000									
Weight (incl. standard adapter plate)	m	kg	83									
		lb _m	183									
Operating noise (at reference ratio and reference speed – ratio-specific values available in cymex [®])	L_{PA}	dB(A)	≤ 71									
Max. permitted housing temperature		°C	+90									
		F	194									
Ambient temperature		°C	0 to +40									
		F	32 to 104									
Lubrication			Lubricated for life									
Direction of rotation			In- and output opposite direction									
Protection class			IP 65									
Metal bellows coupling (recommended product type – validate sizing with cymex [®])			-									
Bore diameter of coupling on the application side		mm	-									
Mass moment of inertia (relates to the drive) Clamping hub diameter [mm]	M	48	J_1	kgcm ²	74	52	43	43	35	30	30	30
				10 ⁻³ in.lb.s ²	65.49	46.02	38.06	38.06	30.98	26.55	26.55	26.55

Please use our sizing software cymex[®] for a detailed sizing – www.wittenstein-cymex.com
Please contact us for optimum sizing at S1 conditions (Continuous operation).

- ^{a)} At max. 10 % M_{2KMax}
- ^{b)} Valid for standard clamping hub diameter
- ^{c)} Refers to center of the output shaft or flange
- ^{d)} Please reduce input speed at higher ambient temperatures
- ^{f)} Please contact us to discuss application-specific service lifetimes

View A

Motor shaft diameter [mm]

2-stage

up to 48⁴⁾ (M)⁵⁾
clamping hub diameter

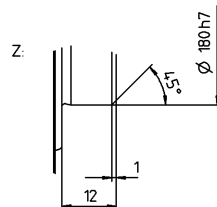
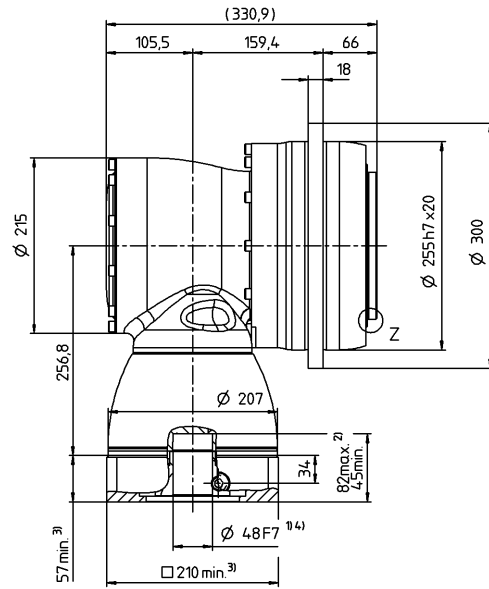
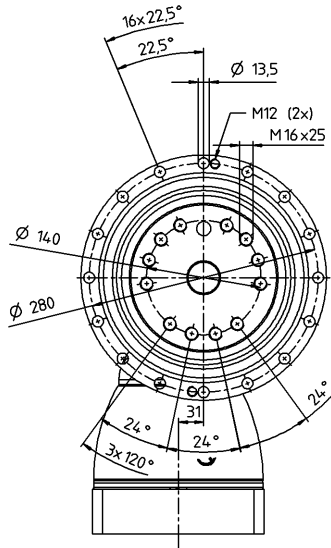

Hypoid gearboxes

TPK+

MF

See technical data sheet for available clamping hub diameters (mass moment of inertia). Dimensions available on request.

Non-tolerated dimensions are nominal dimensions
¹⁾ Check motor shaft fit

²⁾ Min./Max. permissible motor shaft length. Longer motor shafts are possible, please contact alpha.

³⁾ The dimensions depend on the motor

⁴⁾ Smaller motor shaft diameter is compensated by a bushing with a minimum wall thickness of 1 mm

⁵⁾ Standard clamping hub diameter

TPK+ 300 MF 3-stage

			3-stage													
Ratio	<i>i</i>		63	100	125	140	175	200	250	280	350	500	700	1000		
Max. torque ^{a) b)}	T_{2a}	Nm	5250	3840	3840	3840	3840	3840	3840	5250	5250	2820	3948	2800		
		in.lb	46467	33987	33987	33987	33987	33987	33987	46467	46467	24959	34943	24782		
Max. acceleration torque ^{b)} (max. 1000 cycles per hour)	T_{2B}	Nm	3960	3200	3200	3200	3200	3200	3200	3960	3960	2350	3290	2280		
		in.lb	35049	28323	28323	28323	28323	28323	28323	35049	35049	20799	29119	20180		
Nominal torque (at n_n)	T_{2N}	Nm	1800	2000	2000	2000	2000	2000	2000	1800	1800	1800	1800	1600		
		in.lb	15931	17702	17702	17702	17702	17702	17702	15931	15931	15931	15931	14161		
Emergency stop torque ^{a) b)} (permitted 1000 times during the service life of the gearbox)	T_{2Not}	Nm	6300	5250	5250	5250	5250	5250	5250	7350	7350	4500	6300	8750		
		in.lb	55760	46467	46467	46467	46467	46467	46467	65053	65053	39829	55760	77445		
Permitted average input speed (at T_{2a} and 20 °C ambient temperature) ^{d)}	n_{1N}	n_{1T}	2700	2700	2700	2700	2700	2700	2900	2700	2900	3400	3400	3400		
Max. input speed	n_{1Max}	rpm	4000	4000	4000	4000	4000	4000	4000	4000	4000	4000	4000	4000		
Mean no load running torque ^{b)} (at $n_1 = 3000$ rpm and 20 °C gearbox temperature)	T_{012}	Nm	11	6	5	4.2	3.8	3	2.8	2.6	2.4	2.2	2.2	2		
		in.lb	97	53	44	37	34	27	25	23	21	19	19	18		
Max. backlash	j_t	arcmin	Standard ≤ 4 / Reduced ≤ 2													
Torsional rigidity ^{b)}	C_{t21}	Nm/arcmin	699	640	664	640	664	640	664	715	730	658	727	642		
		in.lb/arcmin	6187	5665	5877	5665	5877	5665	5877	6328	6461	5824	6435	5682		
Tilting rigidity	C_{2K}	Nm/arcmin	5560													
		in.lb/arcmin	49210													
Max. axial force ^{c)}	F_{2AMax}	N	33000													
		lb _f	7425													
Max. tilting moment	M_{2KMax}	Nm	5900													
		in.lb	52220													
Efficiency at full load	η	%	92													
Service life ¹⁾	L_h	h	> 20000													
Weight (incl. standard adapter plate)	m	kg	87													
		lb _m	192													
Operating noise (at reference ratio and reference speed – ratio-specific values available in cymex [®])	L_{PA}	dB(A)	≤ 71													
		°C	+90													
Max. permitted housing temperature	F	°C	194													
		°C	0 to +40													
Ambient temperature	F	°C	32 to 104													
		°C	32 to 104													
Lubrication			Lubricated for life													
Direction of rotation			In- and output opposite direction													
Protection class			IP 65													
Metal bellows coupling (recommended product type – validate sizing with cymex [®])			-													
Bore diameter of coupling on the application side		mm	-													
Mass moment of inertia (relates to the drive)	K	38	J_1	kgcm ²	17.8	14.1	12.1	11	10.8	10.2	10.1	10.1	10	9.9	9.9	9.9
				10 ⁻³ in.lb.s ²	15.75	12.48	10.71	9.74	9.56	9.03	8.94	8.94	8.85	8.76	8.76	8.76
Clamping hub diameter [mm]	M	48	J_1	kgcm ²	32.5	28.8	26.8	25.7	25.5	24.9	24.8	24.9	24.8	24.6	24.6	24.6
				10 ⁻³ in.lb.s ²	28.76	25.49	23.72	22.74	22.57	22.04	21.95	22.04	21.95	21.77	21.77	21.77

Please use our sizing software cymex[®] for a detailed sizing – www.wittenstein-cymex.com
Please contact us for optimum sizing at S1 conditions (Continuous operation).

- ^{a)} At max. 10 % M_{2KMax}
- ^{b)} Valid for standard clamping hub diameter
- ^{c)} Refers to center of the output shaft or flange
- ^{d)} Please reduce input speed at higher ambient temperatures
- ¹⁾ Please contact us to discuss application-specific service lifetimes

View A

Motor shaft diameter [mm]

3-stage

up to 38 / 48⁴⁾
(K⁵⁾ / M) clamping
hub diameter

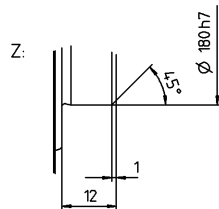
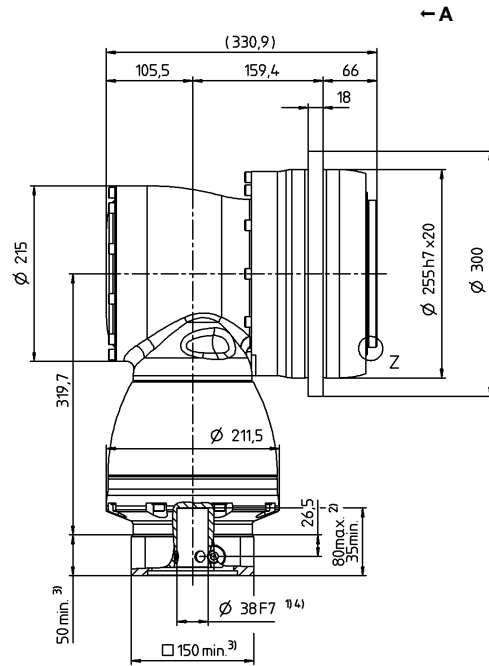
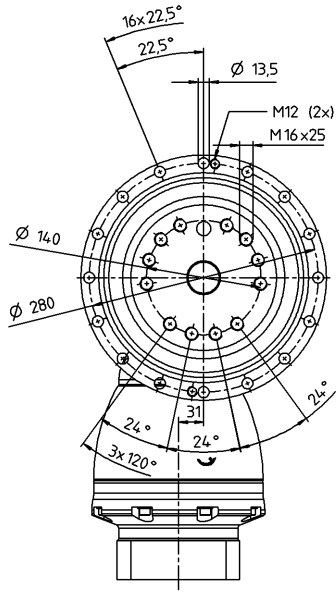

Hypoid gearboxes

TPK+

MF

See technical data sheet for available clamping hub diameters (mass moment of inertia). Dimensions available on request.

Non-tolerated dimensions are nominal dimensions
¹⁾ Check motor shaft fit

²⁾ Min./Max. permissible motor shaft length. Longer motor shafts are possible, please contact alpha.

³⁾ The dimensions depend on the motor

⁴⁾ Smaller motor shaft diameter is compensated by a bushing with a minimum wall thickness of 1 mm

⁵⁾ Standard clamping hub diameter

TPK+ 500 MF 3-stage

			3-stage					
Ratio	i		100	175	350	500	1000	
Max. torque ^{a) b)}	T_{2a}	Nm	5446	6250	6808	4975	4800	
		in.lb	48201	55318	60256	44033	42484	
Max. acceleration torque ^{b)} (max. 1000 cycles per hour)	T_{2B}	Nm	5446	6250	6808	4975	4800	
		in.lb	48201	55318	60256	44033	42484	
Nominal torque (at n_n)	T_{2N}	Nm	3350	3800	3800	2900	2900	
		in.lb	29650	33633	33633	25667	25667	
Emergency stop torque ^{a) b)} (permitted 1000 times during the service life of the gearbox)	T_{2Not}	Nm	10000	11250	14000	15000	15000	
		in.lb	88508	99572	123911	132762	132762	
Permitted average input speed (at T_{2a} and 20 °C ambient temperature) ^{d)}	n_{1N}	n_{1T}	2100	1900	1900	1900	1900	
Max. input speed	n_{1Max}	rpm	5000	5000	5000	5000	5000	
Mean no load running torque ^{b)} (at $n_1 = 3000$ rpm and 20 °C gearbox temperature)	T_{012}	Nm	7.2	11	7.8	7.8	7.8	
		in.lb	64	97	69	69	69	
Max. backlash	j_t	arcmin	Standard ≤ 3.3 / Reduced ≤ 2.3					
Torsional rigidity ^{b)}	C_{t21}	Nm/arcmin	1250	1350	1350	1280	1050	
		in.lb/arcmin	11064	11949	11949	11329	9293	
Tilting rigidity	C_{2K}	Nm/arcmin	9480					
		in.lb/arcmin	83906					
Max. axial force ^{c)}	F_{2AMax}	N	50000					
		lb _f	11250					
Max. tilting moment	M_{2KMax}	Nm	8800					
		in.lb	77887					
Efficiency at full load	η	%	92					
Service life ^{f)}	L_h	h	> 20000					
Weight (incl. standard adapter plate)	m	kg	96					
		lb _m	212					
Operating noise (at reference ratio and reference speed – ratio-specific values available in cymex [®])	L_{PA}	dB(A)	≤ 71					
Max. permitted housing temperature		°C	+90					
		F	194					
Ambient temperature		°C	0 to +40					
		F	32 to 104					
Lubrication			Lubricated for life					
Direction of rotation			In- and output opposite direction					
Protection class			IP 65					
Metal bellows coupling (recommended product type – validate sizing with cymex [®])			-					
Bore diameter of coupling on the application side		mm	-					
Mass moment of inertia (relates to the drive) Clamping hub diameter [mm]	K 38	J_1	kgcm ²	16.7	16.5	16.4	16.4	16.4
			10 ⁻³ in.lb.s ²	14.78	14.6	14.51	14.51	14.51

Please use our sizing software cymex[®] for a detailed sizing – www.wittenstein-cymex.com
Please contact us for optimum sizing at S1 conditions (Continuous operation).

- ^{a)} At max. 10 % M_{2KMax}
- ^{b)} Valid for standard clamping hub diameter
- ^{c)} Refers to center of the output shaft or flange
- ^{d)} Please reduce input speed at higher ambient temperatures
- ^{f)} Please contact us to discuss application-specific service lifetimes

View A

Motor shaft diameter [mm]

3-stage

up to 38⁴⁾ (K)⁵⁾
clamping hub diameter

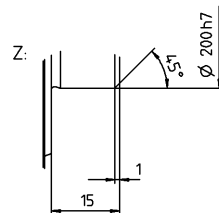
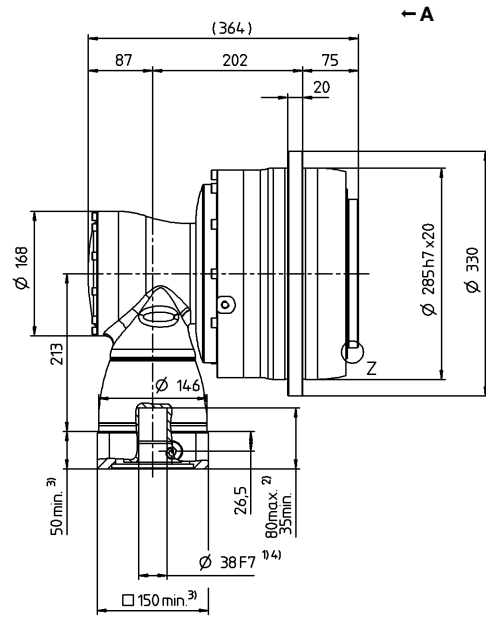
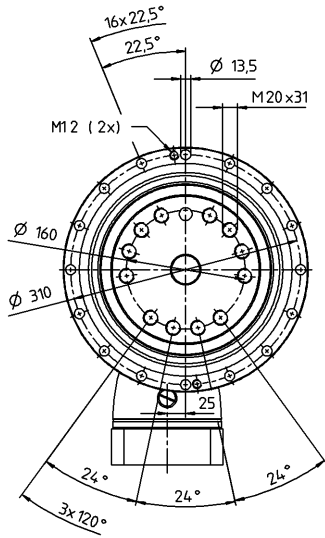

See technical data sheet for available clamping hub diameters (mass moment of inertia). Dimensions available on request.

- Non-tolerated dimensions are nominal dimensions
- ¹⁾ Check motor shaft fit
- ²⁾ Min./Max. permissible motor shaft length. Longer motor shafts are possible, please contact alpha.
- ³⁾ The dimensions depend on the motor
- ⁴⁾ Smaller motor shaft diameter is compensated by a bushing with a minimum wall thickness of 1 mm
- ⁵⁾ Standard clamping hub diameter

TPK+ 025 MA 3-/4-stage

			3-stage							4-stage									
Ratio	<i>i</i>		66	88	110	137.5	154	220	385	330	462	577.5	770	1078	1540	2695	3850	5500	
Max. torque ^{a) b)}	T_{2a}	Nm	583	583	583	583	550	440	583	583	583	583	583	583	583	583	583	583	
		in.lb	5160	5160	5160	5160	4868	3894	5160	5160	5160	5160	5160	5160	5160	5160	5160	5160	
Max. acceleration torque ^{b)} (max. 1000 cycles per hour)	T_{2B}	Nm	530	530	530	530	530	440	530	530	530	530	530	530	530	530	530	530	
		in.lb	4691	4691	4691	4691	4691	3894	4691	4691	4691	4691	4691	4691	4691	4691	4691	4691	
Nominal torque (at n_n)	T_{2N}	Nm	375	375	375	375	375	330	375	375	375	375	375	375	375	375	375	375	
		in.lb	3319	3319	3319	3319	3319	2921	3319	3319	3319	3319	3319	3319	3319	3319	3319	3319	
Emergency stop torque ^{a) b)} (permitted 1000 times during the service life of the gearbox)	T_{2Not}	Nm	880	1100	1100	1200	990	880	1200	880	1200	1200	1200	1200	1200	1200	1200	1200	
		in.lb	7789	9736	9736	10621	8762	7789	10621	7789	10621	10621	10621	10621	10621	10621	10621	10621	
Permitted average input speed (at T_{2a} and 20 °C ambient temperature) ^{d)}	n_{1N}	n_{1T}	2400	2600	2900	2900	2900	2900	2900	4300	4300	4300	4300	4300	4300	5400	5400	5400	
Max. input speed	n_{1Max}	rpm	7500	7500	7500	7500	7500	7500	7500	6000	6000	6000	6000	6000	6000	6000	6000	6000	
Mean no load running torque ^{b)} (at $n_i = 3000$ rpm and 20 °C gearbox temperature)	T_{012}	Nm	1.4	1.2	1.2	1.4	1.6	1.6	1.2	0.45	0.45	0.3	0.3	0.3	0.2	0.2	0.2	0.2	
		in.lb	12	11	11	12	14	14	11	4.0	4.0	2.7	2.7	2.7	1.8	1.8	1.8	1.8	
Max. backlash	j_t	arcmin	Standard ≤ 1.3																
Torsional rigidity ^{b)}	C_{t21}	Nm/arcmin	95	95	96	99	95	94	101	95	101	98	98	102	102	101	101	98	
		in.lb/arcmin	841	841	850	876	841	832	894	841	894	867	867	903	903	894	894	867	
Tilting rigidity	C_{2K}	Nm/arcmin	550																
		in.lb/arcmin	4868																
Max. axial force ^{c)}	F_{2AMax}	N	4800																
		lb _f	1080																
Max. tilting moment	M_{2KMax}	Nm	550																
		in.lb	4868																
Efficiency at full load	η	%	92							90									
Service life ^{f)}	L_h	h	> 20000																
Weight (incl. standard adapter plate)	m	kg	8.4							8.7									
		lb _m	19							19									
Operating noise (at reference ratio and reference speed – ratio-specific values available in cymex [®])	L_{PA}	dB(A)	≤ 66																
Max. permitted housing temperature		°C	+90																
		F	194																
Ambient temperature		°C	0 to +40																
		F	32 to 104																
Lubrication			Lubricated for life																
Direction of rotation			In- and output opposite direction																
Protection class			IP 65																
Metal bellows coupling (recommended product type – validate sizing with cymex [®])			BCT - 00300AAX - 063.000																
Bore diameter of coupling on the application side		mm	X = 030.000 - 056.000																
Mass moment of inertia (relates to the drive) Clamping hub diameter [mm]	B	11	J_1	kgcm ²	-	-	-	-	-	-	-	0.08	0.09	0.06	0.06	0.06	0.06	0.06	
				10 ⁻³ in.lb.s ²	-	-	-	-	-	-	-	0.07	0.08	0.05	0.05	0.05	0.05	0.05	0.05
	C	14	J_1	kgcm ²	0.56	0.46	0.41	0.4	0.37	0.35	0.34	0.19	0.2	0.18	0.18	0.17	0.17	0.17	0.17
				10 ⁻³ in.lb.s ²	0.5	0.41	0.36	0.35	0.33	0.31	0.3	0.17	0.18	0.16	0.16	0.16	0.15	0.15	0.15
E	19	J_1	kgcm ²	0.91	0.81	0.76	0.76	0.72	0.7	0.7	-	-	-	-	-	-	-	-	
			10 ⁻³ in.lb.s ²	0.81	0.72	0.67	0.67	0.64	0.62	0.62	-	-	-	-	-	-	-	-	-

Please use our sizing software cymex[®] for a detailed sizing – www.wittenstein-cymex.com
Please contact us for optimum sizing at S1 conditions (Continuous operation).

- ^{a)} At max. 10 % M_{2KMax}
- ^{b)} Valid for standard clamping hub diameter
- ^{c)} Refers to center of the output shaft or flange
- ^{d)} Please reduce input speed at higher ambient temperatures
- ^{f)} Please contact us to discuss application-specific service lifetimes

View A

3-stage

up to 14/19⁴⁾
(C⁵⁾/E) clamping
hub diameter

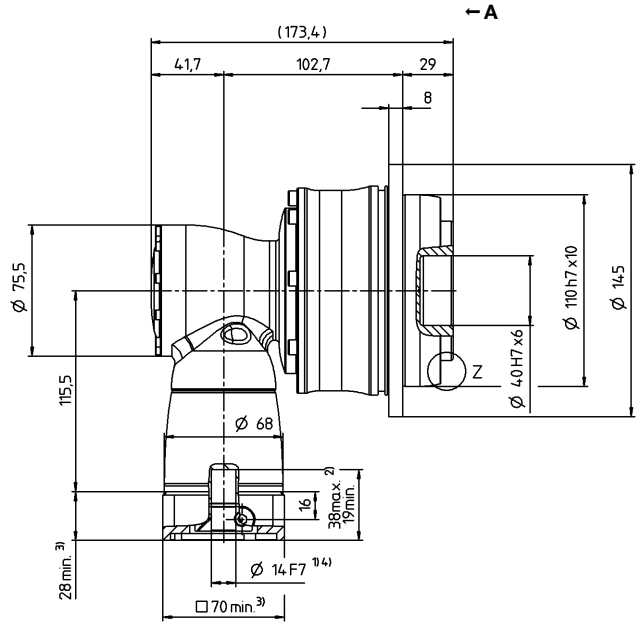
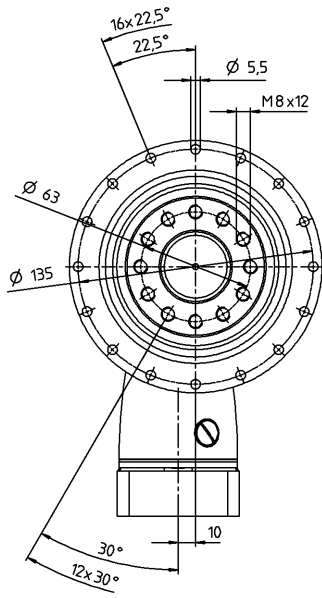

4-stage

up to 11/14⁴⁾
(B⁵⁾/C) clamping
hub diameter

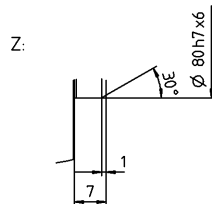
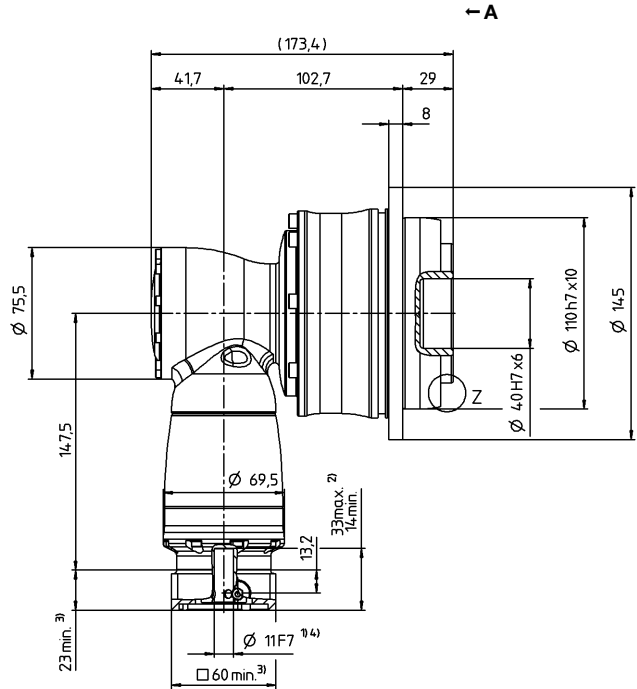
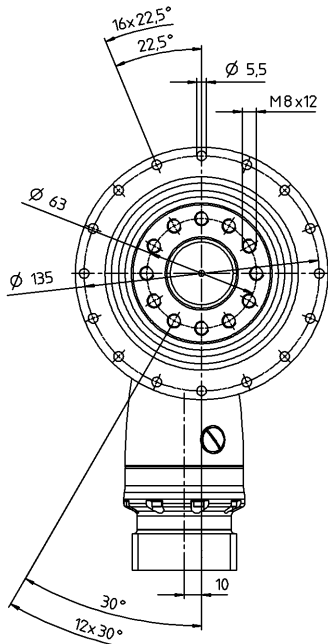

Motor shaft diameter [mm]

Hypoid gearboxes

TPK+

MA

See technical data sheet for available clamping hub diameters (mass moment of inertia). Dimensions available on request.

Non-tolerated dimensions are nominal dimensions
1) Check motor shaft fit

2) Min./Max. permissible motor shaft length. Longer motor shafts are possible, please contact alpha.

3) The dimensions depend on the motor

4) Smaller motor shaft diameter is compensated by a bushing with a minimum wall thickness of 1 mm

5) Standard clamping hub diameter

TPK+ 050 MA 3-/4-stage

			3-stage							4-stage										
Ratio	<i>i</i>		66	88	110	137.5	154	220	385	330	462	577.5	770	1078	1540	2695	3850	5500		
Max. torque ^{a) b)}	T_{2a}	Nm	1402	1402	1402	1402	1320	1100	1402	1402	1402	1402	1402	1402	1402	1402	1402	1402		
		in.lb	12409	12409	12409	12409	11683	9736	12409	12409	12409	12409	12409	12409	12409	12409	12409	12409	12409	
Max. acceleration torque ^{b)} (max. 1000 cycles per hour)	T_{2B}	Nm	992	992	992	992	992	992	992	992	992	992	992	992	992	992	992	992		
		in.lb	8780	8780	8780	8780	8780	8780	8780	8780	8780	8780	8780	8780	8780	8780	8780	8780	8780	
Nominal torque (at n_n)	T_{2N}	Nm	675	675	675	675	675	675	675	675	675	675	675	675	675	675	675	675		
		in.lb	5974	5974	5974	5974	5974	5974	5974	5974	5974	5974	5974	5974	5974	5974	5974	5974	5974	
Emergency stop torque ^{a) b)} (permitted 1000 times during the service life of the gearbox)	T_{2Not}	Nm	2090	2375	2375	2375	2375	2375	2375	2090	2375	2375	2375	2375	2375	2375	2375	2375		
		in.lb	18498	21021	21021	21021	21021	21021	21021	18498	21021	21021	21021	21021	21021	21021	21021	21021	21021	
Permitted average input speed (at T_{2a} and 20 °C ambient temperature) ^{d)}	n_{1N}	n_{1T}	2200	2400	2700	2700	2700	2700	2700	3400	3400	3400	3400	3400	3400	4400	4400	4400		
Max. input speed	n_{1Max}	rpm	7500	7500	7500	7500	7500	7500	7500	6000	6000	6000	6000	6000	6000	6000	6000	6000		
Mean no load running torque ^{b)} (at $n_i = 3000$ rpm and 20 °C gearbox temperature)	T_{012}	Nm	2.9	2.4	2	2.1	2.4	2.1	2	0.6	0.75	0.45	0.45	0.45	0.3	0.15	0.15	0.15		
		in.lb	26	21	18	19	21	19	18	5.3	6.6	4.0	4.0	4.0	2.7	1.3	1.3	1.3		
Max. backlash	j_t	arcmin	Standard ≤ 1.3																	
Torsional rigidity ^{b)}	C_{t21}	Nm/arcmin	202	203	205	210	205	205	215	202	214	208	209	214	214	215	215	217		
		in.lb/arcmin	1788	1797	1814	1859	1814	1814	1903	1788	1894	1841	1850	1894	1894	1903	1903	1921		
Tilting rigidity	C_{2K}	Nm/arcmin	560																	
		in.lb/arcmin	4956																	
Max. axial force ^{c)}	F_{2AMax}	N	6130																	
		lb _f	1379																	
Max. tilting moment	M_{2KMax}	Nm	1335																	
		in.lb	11816																	
Efficiency at full load	η	%	92							90										
Service life ^{f)}	L_h	h	> 20000																	
Weight (incl. standard adapter plate)	m	kg	16.9							17.5										
		lb _m	37							39										
Operating noise (at reference ratio and reference speed – ratio-specific values available in cymex [®])	L_{PA}	dB(A)	≤ 68																	
Max. permitted housing temperature		°C	+90																	
		F	194																	
Ambient temperature		°C	0 to +40																	
		F	32 to 104																	
Lubrication			Lubricated for life																	
Direction of rotation			In- and output opposite direction																	
Protection class			IP 65																	
Metal bellows coupling (recommended product type – validate sizing with cymex [®])			BCT - 00300AAX - 080.000																	
Bore diameter of coupling on the application side		mm	X = 045.000 - 056.000																	
Mass moment of inertia (relates to the drive) Clamping hub diameter [mm]	C	14	J_1	kgcm ²	-	-	-	-	-	-	0.24	0.29	0.2	0.2	0.2	0.19	0.18	0.18	0.18	
				10 ⁻³ in.lb.s ²	-	-	-	-	-	-	-	0.21	0.26	0.18	0.18	0.18	0.17	0.16	0.16	0.16
	E	19	J_1	kgcm ²	1.65	1.3	1.13	1.11	0.99	0.91	0.9	0.68	0.73	0.63	0.63	0.63	0.63	0.63	0.63	0.63
				10 ⁻³ in.lb.s ²	1.46	1.15	1	0.98	0.88	0.81	0.8	0.6	0.65	0.56	0.56	0.56	0.56	0.56	0.56	0.56
H	28	J_1	kgcm ²	3.07	2.71	2.54	2.53	2.4	2.53	2.32	-	-	-	-	-	-	-	-	-	
			10 ⁻³ in.lb.s ²	2.72	2.4	2.25	2.24	2.12	2.24	2.05	-	-	-	-	-	-	-	-	-	-

Please use our sizing software cymex[®] for a detailed sizing – www.wittenstein-cymex.com
Please contact us for optimum sizing at S1 conditions (Continuous operation).

- ^{a)} At max. 10 % M_{2KMax}
- ^{b)} Valid for standard clamping hub diameter
- ^{c)} Refers to center of the output shaft or flange
- ^{d)} Please reduce input speed at higher ambient temperatures
- ^{f)} Please contact us to discuss application-specific service lifetimes

View A

3-stage

up to 19/28⁴⁾
(E⁵⁾/H) clamping
hub diameter

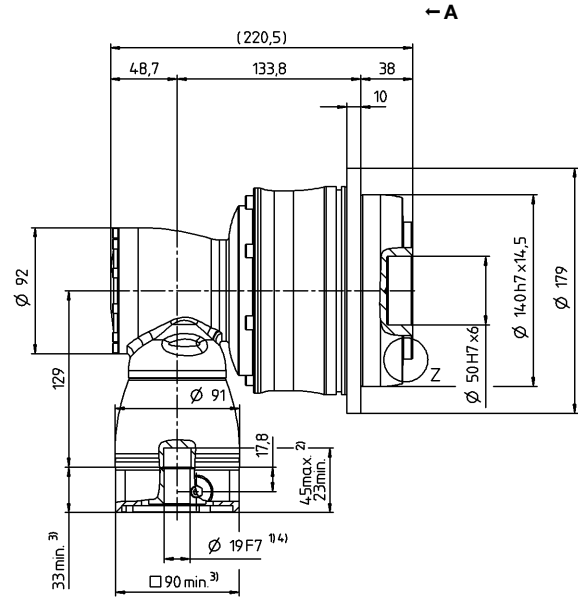
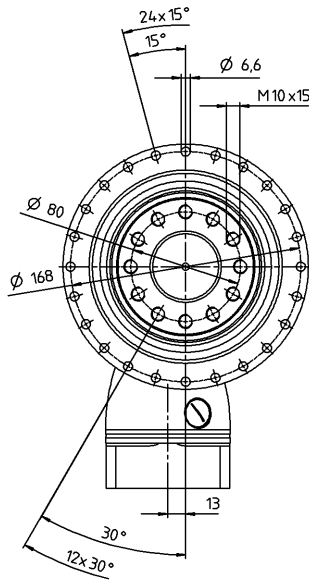

Motor shaft diameter [mm]

4-stage

up to 14/19⁴⁾
(C⁵⁾/E) clamping
hub diameter

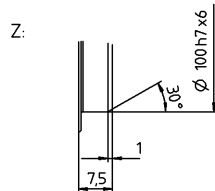
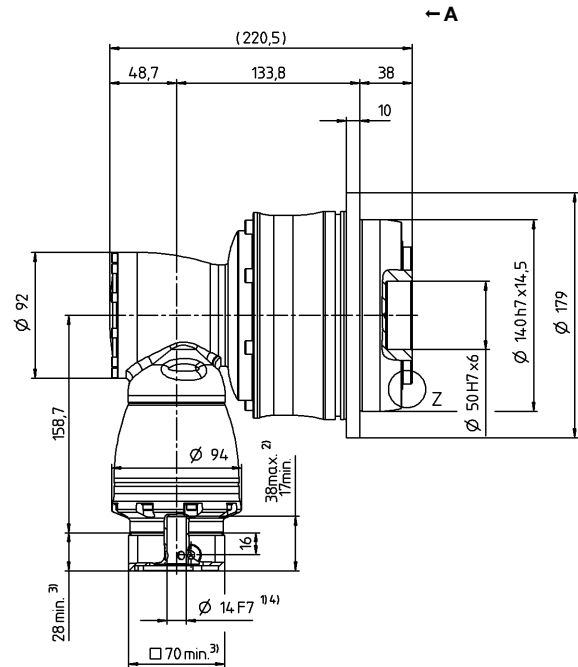
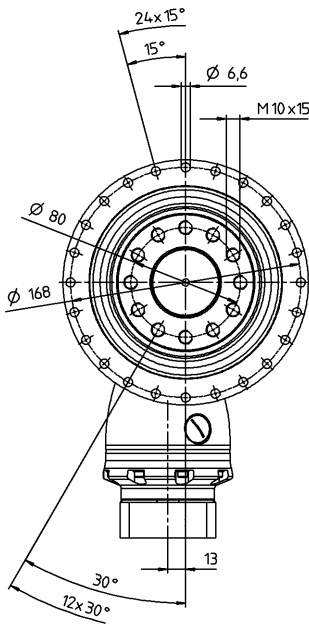

See technical data sheet for available clamping hub diameters (mass moment of inertia). Dimensions available on request.

Non-tolerated dimensions are nominal dimensions
1) Check motor shaft fit

2) Min./Max. permissible motor shaft length. Longer motor shafts are possible, please contact alpha.

3) The dimensions depend on the motor

4) Smaller motor shaft diameter is compensated by a bushing with a minimum wall thickness of 1 mm

5) Standard clamping hub diameter

Hypoid gearboxes

TPK+

MA

TPK+ 110 MA 3-/4-stage

			3-stage							4-stage									
Ratio	<i>i</i>		66	88	110	137.5	154	220	385	330	462	577.5	770	1078	1540	2695	3850	5500	
Max. torque ^{a) b)}	T_{2a}	Nm	3822	3822	3822	3822	3190	2750	3822	3822	3822	3822	3822	3822	3822	3822	3822	3822	3200
		in.lb	33828	33828	33828	33828	28234	24340	33828	33828	33828	33828	33828	33828	33828	33828	33828	33828	33828
Max. acceleration torque ^{b)} (max. 1000 cycles per hour)	T_{2B}	Nm	3100	3100	3100	3100	3100	2750	3100	3100	3100	3100	3100	3100	3100	3100	3100	3100	2400
		in.lb	27437	27437	27437	27437	27437	24340	27437	27437	27437	27437	27437	27437	27437	27437	27437	27437	21242
Nominal torque (at n_n)	T_{2N}	Nm	1650	1650	1650	1650	1650	1650	1650	1650	1650	1650	1650	1650	1650	1650	1650	1650	1400
		in.lb	14604	14604	14604	14604	14604	14604	14604	14604	14604	14604	14604	14604	14604	14604	14604	14604	12391
Emergency stop torque ^{a) b)} (permitted 1000 times during the service life of the gearbox)	T_{2Not}	Nm	4840	5720	5720	6500	5610	5500	6500	4840	6500	6050	6500	6500	6500	6500	6500	6500	6500
		in.lb	42838	50627	50627	57530	49653	48679	57530	42838	57530	53547	57530	57530	57530	57530	57530	57530	57530
Permitted average input speed (at T_{2a} and 20 °C ambient temperature) ^{d)}	n_{1N}	n_{1T}	2100	2300	2600	2600	2400	2400	2400	3000	3000	3000	3000	3000	3000	4100	4100	4100	
Max. input speed	n_{1Max}	rpm	5500	5500	5500	5500	5500	5500	5500	4500	4500	4500	4500	4500	4500	4500	4500	4500	
Mean no load running torque ^{b)} (at $n_i = 3000$ rpm and 20 °C gearbox temperature)	T_{012}	Nm	6	4.6	3.6	3.4	4.4	3.5	3.3	1.4	1.5	1.1	0.9	0.9	0.45	0.45	0.3	0.3	
		in.lb	53	41	32	30	39	31	29	12	13	9.7	8.0	8.0	4.0	4.0	2.7	2.7	
Max. backlash	j_t	arcmin	Standard ≤ 1.3																
Torsional rigidity ^{b)}	C_{t21}	Nm/arcmin	634	642	654	675	654	648	687	634	682	662	667	685	685	689	687	658	
		in.lb/arcmin	5611	5682	5788	5974	5788	5735	6080	5611	6036	5859	5903	6063	6063	6098	6080	5824	
Tilting rigidity	C_{2K}	Nm/arcmin	1452																
		in.lb/arcmin	12851																
Max. axial force ^{c)}	F_{2AMax}	N	10050																
		lb _f	2261																
Max. tilting moment	M_{2KMax}	Nm	3280																
		in.lb	29031																
Efficiency at full load	η	%	92							90									
Service life ^{f)}	L_h	h	> 20000																
Weight (incl. standard adapter plate)	m	kg	39.9							40.6									
		lb _m	88							90									
Operating noise (at reference ratio and reference speed – ratio-specific values available in cymex [®])	L_{PA}	dB(A)	≤ 70																
Max. permitted housing temperature		°C	+90																
		F	194																
Ambient temperature		°C	0 to +40																
		F	32 to 104																
Lubrication			Lubricated for life																
Direction of rotation			In- and output opposite direction																
Protection class			IP 65																
Metal bellows coupling (recommended product type – validate sizing with cymex [®])			BCT - 01500AAX - 125.000																
Bore diameter of coupling on the application side		mm	X = 055.000 - 070.000																
Mass moment of inertia (relates to the drive) Clamping hub diameter [mm]	E	19	J_1	kgcm ²	-	-	-	-	-	-	0.89	1.06	0.76	0.76	0.76	0.69	0.68	0.68	0.68
				10 ⁻³ in.lb.s ²	-	-	-	-	-	-	0.79	0.94	0.67	0.67	0.67	0.61	0.6	0.6	0.6
	G	24	J_1	kgcm ²	-	-	-	-	-	-	2.46	2.63	2.33	2.32	2.32	2.26	2.25	2.25	2.25
				10 ⁻³ in.lb.s ²	-	-	-	-	-	-	2.18	2.33	2.06	2.05	2.05	2	1.99	1.99	1.99
	H	28	J_1	kgcm ²	5.48	4.27	3.64	3.58	3.14	2.87	2.84	-	-	-	-	-	-	-	-
				10 ⁻³ in.lb.s ²	4.85	3.78	3.22	3.17	2.78	2.54	2.51	-	-	-	-	-	-	-	-
	K	38	J_1	kgcm ²	12.72	11.52	10.89	10.83	10.39	10.12	10.09	-	-	-	-	-	-	-	-
				10 ⁻³ in.lb.s ²	11.26	10.2	9.64	9.58	9.2	8.96	8.93	-	-	-	-	-	-	-	-

Please use our sizing software cymex[®] for a detailed sizing – www.wittenstein-cymex.com
Please contact us for optimum sizing at S1 conditions (Continuous operation).

- ^{a)} At max. 10 % M_{2KMax}
- ^{b)} Valid for standard clamping hub diameter
- ^{c)} Refers to center of the output shaft or flange
- ^{d)} Please reduce input speed at higher ambient temperatures
- ^{f)} Please contact us to discuss application-specific service lifetimes

View A

3-stage

up to 28/38⁴⁾
(H⁵⁾/K) clamping
hub diameter

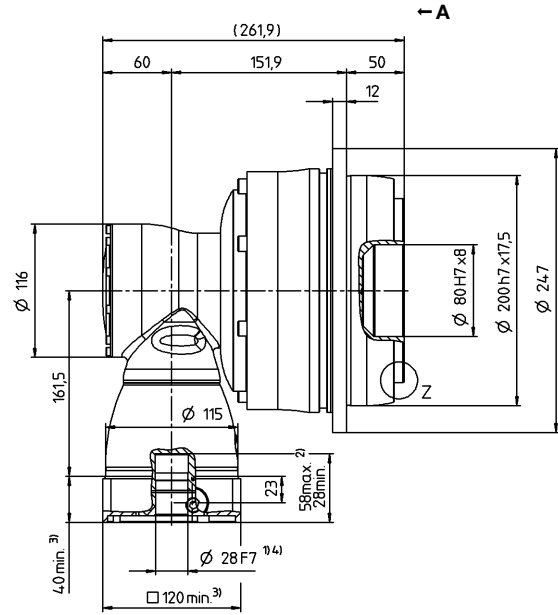
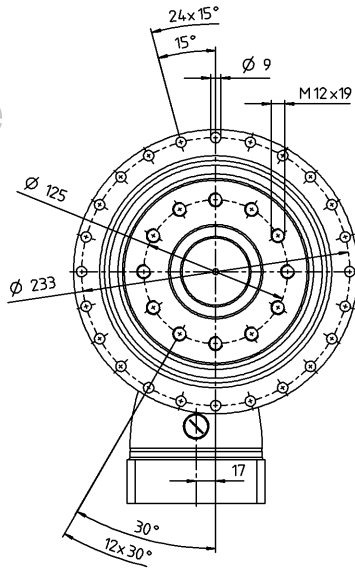

4-stage

up to 19/24⁴⁾
(E⁵⁾/G) clamping
hub diameter

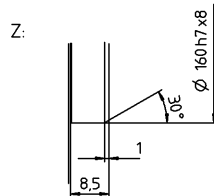
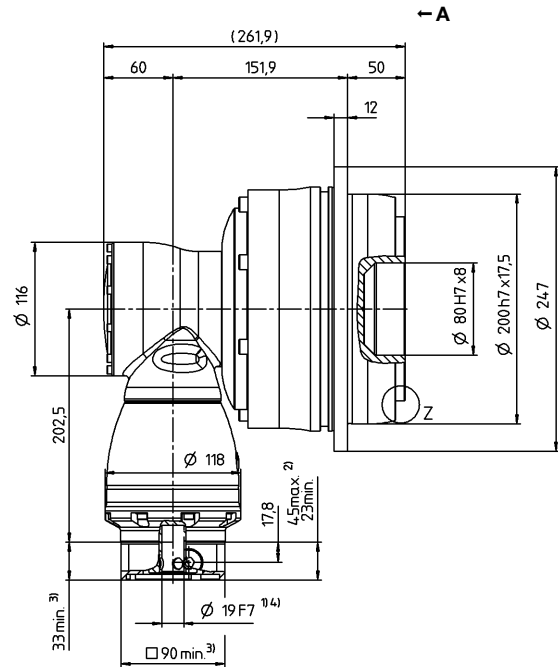
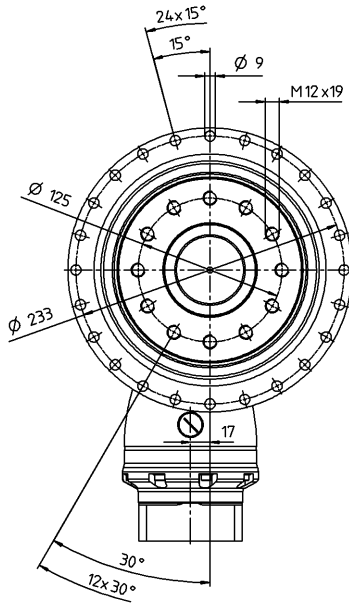

Motor shaft diameter [mm]

Hypoid gearboxes

TPK+

MA

See technical data sheet for available clamping hub diameters (mass moment of inertia). Dimensions available on request.

Non-tolerated dimensions are nominal dimensions
1) Check motor shaft fit

2) Min./Max. permissible motor shaft length. Longer motor shafts are possible, please contact alpha.

3) The dimensions depend on the motor

4) Smaller motor shaft diameter is compensated by a bushing with a minimum wall thickness of 1 mm

5) Standard clamping hub diameter

TPK+ 300 MA 3-/4-stage

			3-stage							4-stage									
Ratio	<i>i</i>		66	88	110	137.5	154	220	385	330	462	577.5	770	1078	1540	2695	3850	5500	
Max. torque ^{a) b)}	T_{2a}	Nm	7535	7535	7535	7535	5500	4620	7535	7535	7535	7535	7535	7535	7535	7535	7535	7535	5473
		in.lb	66691	66691	66691	66691	48679	40891	66691	66691	66691	66691	66691	66691	66691	66691	66691	66691	66691
Max. acceleration torque ^{b)} (max. 1000 cycles per hour)	T_{2B}	Nm	6600	6600	6600	6600	5500	4620	6600	6600	6600	6600	6600	6600	6600	6600	6600	6600	4680
		in.lb	58415	58415	58415	58415	48679	40891	58415	58415	58415	58415	58415	58415	58415	58415	58415	58415	58415
Nominal torque (at n_n)	T_{2N}	Nm	3500	3500	3500	3500	3500	3500	3500	3500	3500	3500	3500	3500	3500	3500	3500	3500	3500
		in.lb	30978	30978	30978	30978	30978	30978	30978	30978	30978	30978	30978	30978	30978	30978	30978	30978	30978
Emergency stop torque ^{a) b)} (permitted 1000 times during the service life of the gearbox)	T_{2Not}	Nm	8800	11000	11000	13750	9900	8800	15296	8800	15296	11000	13750	15296	15296	15296	15296	15296	15333
		in.lb	77887	97359	97359	121699	87623	77887	135382	77887	135382	97359	121699	135382	135382	135382	135382	135382	135709
Permitted average input speed (at T_{2a} and 20 °C ambient temperature) ^{d)}	n_{1N}	n_{1T}	1800	1900	2100	2100	1900	1900	1900	2800	2800	2800	2800	2800	2800	3100	3800	3800	
Max. input speed	n_{1Max}	rpm	5000	5000	5000	5000	5000	5000	5000	4500	4500	4500	4500	4500	4500	4500	4500	4500	
Mean no load running torque ^{b)} (at $n_1 = 3000$ rpm and 20 °C gearbox temperature)	T_{012}	Nm	11	8.2	6.9	6.5	9.2	7.8	7.5	2.3	3.3	1.5	1.4	1.2	0.9	0.6	0.6	0.6	
		in.lb	97	73	61	58	81	69	66	20	29	13	12	11	8.0	5.3	5.3	5.3	
Max. backlash	j_t	arcmin	Standard ≤ 3.3 / Reduced ≤ 1.8																
Torsional rigidity ^{b)}	C_{121}	Nm/arcmin	1099	1108	1114	960	1114	1111	979	1099	976	953	958	978	978	979	979	989	
		in.lb/arcmin	9727	9807	9860	8497	9860	9833	8665	9727	8638	8435	8479	8656	8656	8665	8665	8753	
Tilting rigidity	C_{2K}	Nm/arcmin	5560																
		in.lb/arcmin	49210																
Max. axial force ^{c)}	F_{2AMax}	N	33000																
		lb _f	7425																
Max. tilting moment	M_{2KMax}	Nm	6500																
		in.lb	57530																
Efficiency at full load	η	%	92							90									
Service life ¹⁾	L_h	h	> 20000																
Weight (incl. standard adapter plate)	m	kg	83							87									
		lb _m	183							192									
Operating noise (at reference ratio and reference speed – ratio-specific values available in cymex [®])	L_{PA}	dB(A)	≤ 71																
Max. permitted housing temperature		°C	+90																
		F	194																
Ambient temperature		°C	0 to +40																
		F	32 to 104																
Lubrication			Lubricated for life																
Direction of rotation			In- and output opposite direction																
Protection class			IP 65																
Metal bellows coupling (recommended product type – validate sizing with cymex [®])			BCT - 04000AAX - 145.000																
Bore diameter of coupling on the application side		mm	X = 070.000 - 100.000																
Mass moment of inertia (relates to the drive)	G 24	J_1	kgcm ²	-	-	-	-	-	-	-	3.32	4.24	2.8	2.79	2.79	2.49	2.43	2.42	2.42
			10 ⁻³ in.lb.s ²	-	-	-	-	-	-	-	-	2.94	3.75	2.48	2.47	2.47	2.2	2.15	2.14
Clamping hub diameter [mm]	K 38	J_1	kgcm ²	26.04	19.71	16.71	16.58	14.26	12.89	12.83	10.23	11.15	9.71	9.7	9.7	9.4	9.34	9.33	9.33
			10 ⁻³ in.lb.s ²	23.05	17.44	14.79	14.67	12.62	11.41	11.35	9.05	9.87	8.59	8.58	8.58	8.32	8.27	8.26	8.26

Please use our sizing software cymex[®] for a detailed sizing – www.wittenstein-cymex.com
Please contact us for optimum sizing at S1 conditions (Continuous operation).

- ^{a)} At max. 10 % M_{2KMax}
- ^{b)} Valid for standard clamping hub diameter
- ^{c)} Refers to center of the output shaft or flange
- ^{d)} Please reduce input speed at higher ambient temperatures
- ¹⁾ Please contact us to discuss application-specific service lifetimes

View A

3-stage

up to 38⁴⁾ (K)⁵⁾
clamping hub diameter

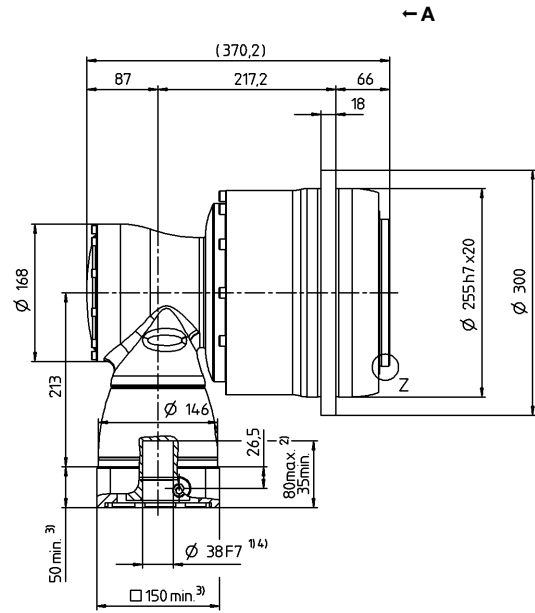
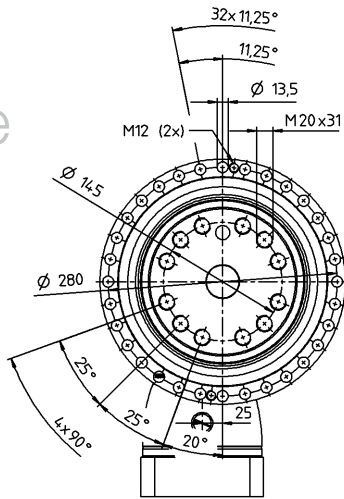

Motor shaft diameter [mm]

4-stage

up to 24/38⁴⁾
(G⁵⁾/K) clamping hub diameter

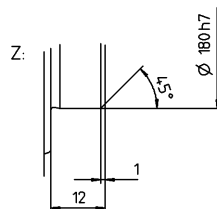
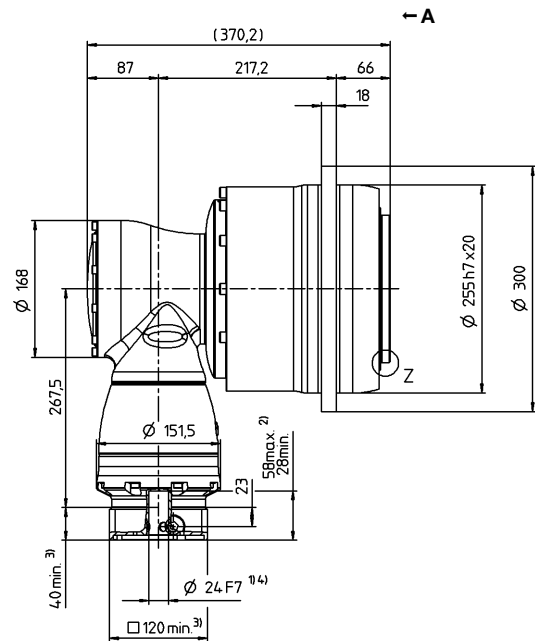
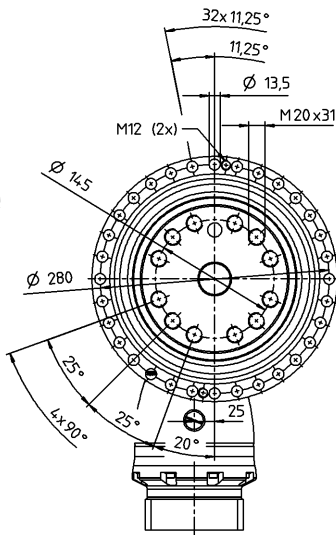

See technical data sheet for available clamping hub diameters (mass moment of inertia). Dimensions available on request.

Non-tolerated dimensions are nominal dimensions
¹⁾ Check motor shaft fit

²⁾ Min./Max. permissible motor shaft length. Longer motor shafts are possible, please contact alpha.

³⁾ The dimensions depend on the motor

⁴⁾ Smaller motor shaft diameter is compensated by a bushing with a minimum wall thickness of 1 mm

⁵⁾ Standard clamping hub diameter

Hypoid gearboxes

TPK+

MA

TPK+ 500 MA 3-/4-stage

			3-stage							4-stage									
Ratio	<i>i</i>		66	88	110	137.5	154	220	385	330	462	577.5	770	1078	1540	2695	3850	5500	
Max. torque ^{a) b)}	T_{2a}	Nm	10450	10450	10450	10450	10450	10340	10450	10450	10450	10450	10450	10450	10450	10450	10450	10450	10450
		in.lb	92491	92491	92491	92491	92491	91517	92491	92491	92491	92491	92491	92491	92491	92491	92491	92491	92491
Max. acceleration torque ^{b)} (max. 1000 cycles per hour)	T_{2B}	Nm	10450	10450	10450	10450	10450	10340	10450	10450	10450	10450	10450	10450	10450	10450	10450	10450	8640
		in.lb	92491	92491	92491	92491	92491	91517	92491	92491	92491	92491	92491	92491	92491	92491	92491	92491	92491
Nominal torque (at n_n)	T_{2N}	Nm	5400	5400	5400	5400	5400	5400	5400	5400	5400	5400	5400	5400	5400	5400	5400	5400	5400
		in.lb	47794	47794	47794	47794	47794	47794	47794	47794	47794	47794	47794	47794	47794	47794	47794	47794	47794
Emergency stop torque ^{a) b)} (permitted 1000 times during the service life of the gearbox)	T_{2Not}	Nm	19800	23100	23100	25000	21340	19800	25000	19800	25000	24750	25000	25000	25000	25000	25000	25000	25000
		in.lb	175246	204453	204453	221270	188876	175246	221270	175246	221270	219057	221270	221270	221270	221270	221270	221270	221270
Permitted average input speed (at T_{2a} and 20 °C ambient temperature) ^{d)}	n_{1N}	n_{1T}	1500	1700	1900	1900	1700	1700	1700	2600	2600	2600	2600	2600	2600	3100	3300	3300	
Max. input speed	n_{1Max}	rpm	4500	4500	4500	4500	4500	4500	4500	4000	4000	4000	4000	4000	4000	4000	4000	4000	
Mean no load running torque ^{b)} (at $n_1 = 3000$ rpm and 20 °C gearbox temperature)	T_{012}	Nm	19	15	13	13	17	15	15	4.1	6	3	2.7	2.6	1.8	1.7	1.5	1.5	
		in.lb	168	133	115	115	150	133	133	36	53	27	24	23	16	15	13	13	
Max. backlash	j_t	arcmin	Standard ≤ 3.3 / Reduced ≤ 1.8																
Torsional rigidity ^{b)}	C_{121}	Nm/arcmin	1879	1890	1901	1747	1899	1898	1772	1879	1766	1735	1742	1770	1770	1772	1772	1786	
		in.lb/arcmin	16631	16728	16825	15462	16808	16799	15684	16631	15631	15356	15418	15666	15666	15684	15684	15808	
Tilting rigidity	C_{2K}	Nm/arcmin	9480																
		in.lb/arcmin	83906																
Max. axial force ^{c)}	F_{2AMax}	N	50000																
		lb _f	11250																
Max. tilting moment	M_{2KMax}	Nm	9500																
		in.lb	84083																
Efficiency at full load	η	%	92							90									
Service life ¹⁾	L_h	h	> 20000																
Weight (incl. standard adapter plate)	<i>m</i>	kg	120							124									
		lb _m	265							274									
Operating noise (at reference ratio and reference speed – ratio-specific values available in cymex [®])	L_{PA}	dB(A)	≤ 71																
Max. permitted housing temperature		°C	+90																
		F	194																
Ambient temperature		°C	0 to +40																
		F	32 to 104																
Lubrication			Lubricated for life																
Direction of rotation			In- and output opposite direction																
Protection class			IP 65																
Metal bellows coupling (recommended product type – validate sizing with cymex [®])			BCT - 10000AAX - 166.000																
Bore diameter of coupling on the application side		mm	X = 080.000 - 180.000																
Mass moment of inertia (relates to the drive)	K 38	J_1	kgcm ²	-	-	-	-	-	-	-	12.43	15.36	10.93	10.92	10.91	10.13	9.95	9.91	9.91
			10 ⁻³ in.lb.s ²	-	-	-	-	-	-	-	-	11	13.59	9.67	9.66	9.66	8.97	8.81	8.77
Clamping hub diameter [mm]	M 48	J_1	kgcm ²	75.54	52.83	42.94	42.67	34.37	29.87	29.73	27.14	30.07	25.64	25.63	25.62	24.84	24.66	24.62	24.62
			10 ⁻³ in.lb.s ²	66.85	46.75	38	37.76	30.42	26.43	26.31	24.02	26.61	22.69	22.68	22.67	21.98	21.82	21.79	21.79

Please use our sizing software cymex[®] for a detailed sizing – www.wittenstein-cymex.com
Please contact us for optimum sizing at S1 conditions (Continuous operation).

- ^{a)} At max. 10 % M_{2KMax}
- ^{b)} Valid for standard clamping hub diameter
- ^{c)} Refers to center of the output shaft or flange
- ^{d)} Please reduce input speed at higher ambient temperatures
- ¹⁾ Please contact us to discuss application-specific service lifetimes

View A

3-stage

up to 48⁴⁾ (M)⁵⁾
clamping hub diameter

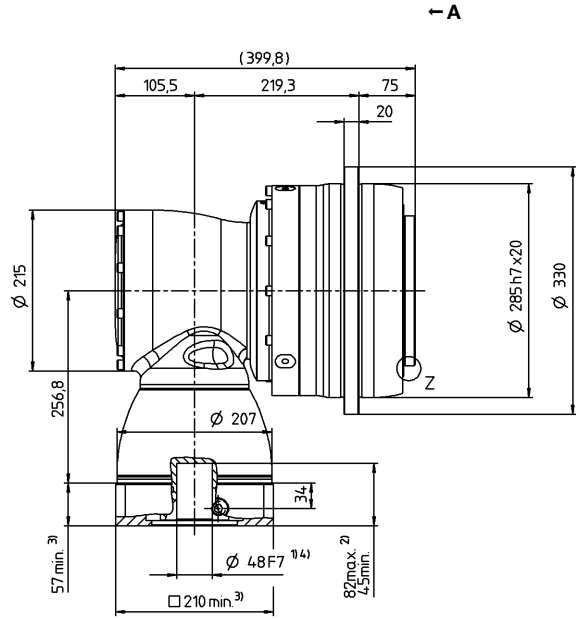
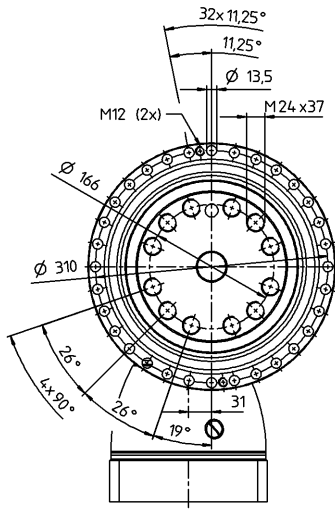

← A

Motor shaft diameter [mm]

4-stage

up to 38 / 48⁴⁾
(K⁵⁾ / M) clamping hub diameter

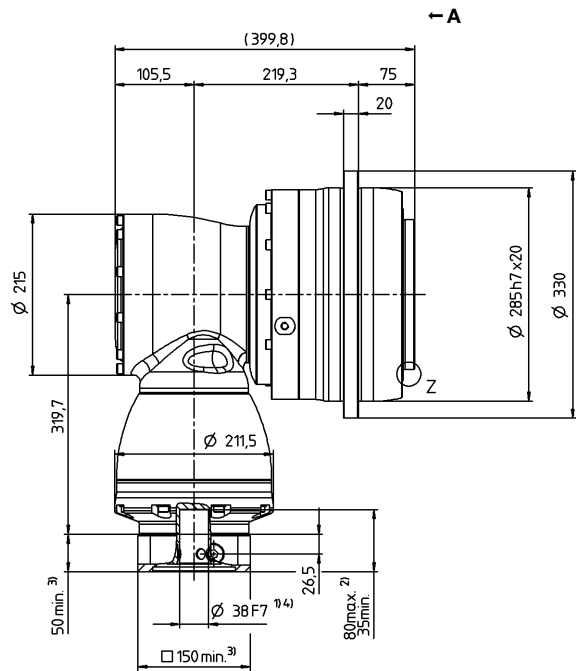
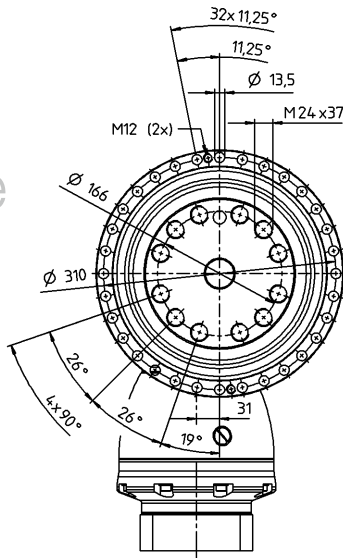

← A

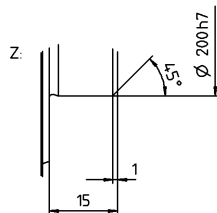

Hypoid gearboxes

TPK⁺

MA

See technical data sheet for available clamping hub diameters (mass moment of inertia). Dimensions available on request.

Non-tolerated dimensions are nominal dimensions

¹⁾ Check motor shaft fit

²⁾ Min./Max. permissible motor shaft length. Longer motor shafts are possible, please contact alpha.

³⁾ The dimensions depend on the motor

⁴⁾ Smaller motor shaft diameter is compensated by a bushing with a minimum wall thickness of 1 mm

⁵⁾ Standard clamping hub diameter